

User Manual

APM32A072xBTx

Arm[®] Cortex[®]-M0+ based 32-bit MCU(Automotive grade)

Version: V1.0

Contents

1	Introduction and Document Description Rules	9
1.1	Introduction	9
1.2	Document Description Rules	9
2	System Architecture	12
2.1	Full Name and Abbreviation Description of Terms.....	12
2.2	System Architecture Block Diagram	12
2.3	Memory Mapping	13
2.4	Startup Configuration	13
3	FLASH Memory	15
3.1	Full Name and Abbreviation Description of Terms.....	15
3.2	Characteristics of Flash Memory	15
3.3	Flash Memory Structure.....	15
3.4	Register Address Mapping.....	19
3.5	Register Functional Description	19
4	System Configuration Controller (SYSCFG).....	24
4.1	Full Name and Abbreviation Description of Terms.....	24
4.2	Register Address Mapping.....	24
4.3	Register Functional Description	24
5	Reset and Clock Management (RCM).....	31
5.1	Full Name and Abbreviation Description of Terms.....	31
5.2	Reset Functional Description	31
5.3	Functional Description of Clock Management	33
5.4	Register Address Mapping.....	40
5.5	Register Functional Description	40
6	Clock Recovery System (CRS)	58
6.1	Full Name and Abbreviation Description of Terms.....	58
6.2	Introduction	58
6.3	Main Characteristics.....	58
6.4	Functional Description	59
6.5	Register Address Mapping.....	60

6.6	Register Functional Description	60
7	Power Management Unit (PMU)	64
7.1	Full Name and Abbreviation Description of Terms.....	64
7.2	Introduction	64
7.3	Structure Block Diagram	64
7.4	Functional Description	65
7.5	Register Address Mapping.....	69
7.6	Register Functional Description	69
8	Nested Vector Interrupt Controller (NVIC)	72
8.1	Full Name and Abbreviation Description of Terms.....	72
8.2	Introduction	72
8.3	Main Characteristics.....	72
8.4	Interrupt and Exception Vector Table	72
9	External Interrupt and Event Controller (EINT)	74
9.1	Introduction	74
9.2	Main Characteristics.....	74
9.3	Functional Description	74
9.4	Register Address Mapping.....	76
9.5	Register Functional Description	76
10	Direct Memory Access (DMA)	80
10.1	Full Name and Abbreviation Description of Terms.....	80
10.2	Introduction	80
10.3	Main Characteristics.....	80
10.4	Functional Description	81
10.5	Register Address Mapping.....	86
10.6	Register Functional Description	87
11	Debug MCU (DBGMCU)	91
11.1	Full Name and Abbreviation Description of Terms.....	91
11.2	Introduction	91
11.3	Main Characteristics.....	91
11.4	Functional Description	92
11.5	Register Address Mapping.....	92

11.6	Register functional description.....	92
12	General-purpose/Alternate function Input/Output Pin (GPIO/AFIO)	96
12.1	Full Name and Abbreviation Description of Terms.....	96
12.2	Main Characteristics.....	96
12.3	Structure Block Diagram	96
12.4	Functional Description	97
12.5	Register Address Mapping.....	101
12.6	Register Functional Description	102
13	Timer Overview	107
13.1	Full Name and Abbreviation Description of Terms.....	107
13.2	Timer Category and Main Difference	107
14	Basic Timer (TMR6/7).....	110
14.1	Introduction	110
14.2	Main Characteristics.....	110
14.3	Structure Block Diagram	110
14.4	Functional Description	110
14.5	Register Address Mapping.....	112
14.6	Register Functional Description	112
15	General-purpose Timer (TMR2/3).....	116
15.1	Introduction	116
15.2	Main Characteristics.....	116
15.3	Structure Block Diagram	117
15.4	Functional Description	117
15.5	Register Address Mapping.....	129
15.6	Register Functional Description	130
16	General-purpose Timer (TMR14).....	145
16.1	Introduction	145
16.2	Main Characteristics.....	145
16.3	Structure Block Diagram	145
16.4	Functional Description	146
16.5	Register Address Mapping.....	153

16.6	Register Functional Description	153
17	General-purpose Timer (TMR15/16/17).....	160
17.1	Introduction	160
17.2	Main Characteristics.....	160
17.3	Structure Block Diagram	161
17.4	Functional Description	162
17.5	Register Address Mapping.....	172
17.6	Register Functional Description	173
17.7	TMR16 and TMR17 Register Address Mapping	185
17.8	TMR16 and TMR17 Register Functional Description	186
18	Advanced Timer (TMR1)	197
18.1	Introduction	197
18.2	Main Characteristics.....	197
18.3	Structure Block Diagram	198
18.4	Functional Description	198
18.5	Register Address Mapping.....	214
18.6	Register Functional Description	215
19	Infrared Timer (IRTMR)	232
19.1	Introduction	232
19.2	Functional Description	232
20	Watchdog Timer (WDT).....	233
20.1	Introduction	233
20.2	Independent Watchdog	233
20.3	Window Watchdog	235
20.4	IWDT Register Address Mapping.....	236
20.5	IWDT Register Functional Description.....	237
20.6	WWDT Register Address Mapping	239
20.7	WWDT Register Functional Description	239
21	Real-time Clock (RTC)	241
21.1	Full Name and Abbreviation Description of Terms.....	241
21.2	Introduction	241
21.3	Main Characteristics.....	241

21.4	Structure Block Diagram	241
21.5	Functional Description	242
21.6	Register Address Mapping.....	248
21.7	Register Functional Description	248
22	Universal Synchronous/Asynchronous Transceiver (USART) 261	
22.1	Full Name and Abbreviation Description of Terms.....	261
22.2	Introduction	261
22.3	Main Characteristics.....	261
22.4	Functional Description	263
22.5	Register Address Mapping.....	279
22.6	Register Functional Description	279
23	Internal Integrated Circuit Interface (I2C).....	292
23.1	Full Name and Abbreviation Description of Terms.....	292
23.2	Introduction	292
23.3	Main Characteristics.....	292
23.4	Structure Block Diagram	293
23.5	Functional Description	294
23.6	Register Address Mapping.....	304
23.7	Register Functional Description	305
24	Serial Peripheral Interface/On-chip Audio Interface (SPI/I2S) ..	314
24.1	Full Name and Abbreviation Description of Terms.....	314
24.2	Introduction	314
24.3	Main Characteristics of SPI.....	314
24.4	Main Characteristics of I2S	315
24.5	SPI Functional Description.....	316
24.6	I2S Functional Description	327
24.7	Register Address Mapping.....	336
24.8	Register Functional Description	337
25	Controller Area Network (CAN).....	345
25.1	Full Name and Abbreviation Description of Terms.....	345
25.2	Introduction	345
25.3	Main Characteristics.....	345

25.4	Functional Description	345
25.5	Register Address Mapping.....	353
25.6	Register Functional Description.....	354
26	Full-speed USB Device (USB)	368
26.1	Introduction	368
26.2	USB Functional Description	368
26.3	Register Address Mapping.....	368
26.4	USB Register Functional Description.....	369
27	HDMI-CEC Controller (HDMI-CEC)	378
27.1	Introduction	378
27.2	Main Characteristics.....	378
27.3	Structure block diagram	378
27.4	Main Functions	378
27.5	Register Address Mapping.....	381
27.6	Register Functional Description.....	381
28	Analog-to-digital Converter (ADC)	387
28.1	Introduction	387
28.2	Main Characteristics.....	387
28.3	ADC Functional Description.....	388
28.4	Register Address Mapping.....	392
28.5	Register Functional Description.....	392
29	Digital-to-analog Converter (DAC)	399
29.1	Introduction	399
29.2	Main Characteristics.....	399
29.3	Structure Block Diagram	399
29.4	Functional Description	400
29.5	Register Address Mapping.....	403
29.6	Register Functional Description.....	404
30	Touch Sensing Controller (TSC)	410
30.1	Introduction	410
30.2	Main Characteristics.....	410
30.3	Structure Block Diagram	410

30.4	Functional Description	411
30.5	Register Address Mapping.....	413
30.6	Register Functional Description.....	414
31	Comparator (COMP).....	419
31.1	Full Name and Abbreviation Description of Terms.....	419
31.2	Introduction	419
31.3	Main Characteristics.....	419
31.4	Structure Block Diagram	419
31.5	Functional Description	420
31.6	Register Address Mapping.....	420
31.7	Register Functional Description.....	421
32	Cyclic Redundancy Check Computing Unit (CRC)	424
32.1	Introduction	424
32.2	Functional Description	424
32.3	Register Address Mapping.....	425
32.4	Register Functional Description.....	425
33	Chip Electronic Signature	427
33.1	Introduction	427
33.2	Functional Description	427
33.3	Register Functional Description.....	427
34	Version History.....	428

1 Introduction and Document Description Rules

1.1 Introduction

This reference manual provides application developers with all the information about how to use MCU (micro-controller) system architecture, memory and peripherals.

For information about Arm® Cortex®-M0+ core, please refer to *Arm® Cortex®-M0+ Technical Reference Manual*; please refer to the corresponding datasheet for detailed data such as model information, dimension and electrical characteristics of the device; for all MCU series models, please refer to the corresponding data manual for memory mapping, peripheral existence and their number.

It is hereby declared that Geehy Semiconductor Co., Ltd., hereinafter refer to as "Geehy".

1.2 Document Description Rules

1.2.1 "Register Functional Description" Rules

- (1) Control (CTRL) registers are all "set to 1 and cleared by software", unless otherwise specified.
- (2) The control registers are usually followed by verb abbreviations to make a distinction. The verbs can be: EN-Enable, CFG-Configure, D-Disable, SET-Setup and SEL-Select
- (3) The state register abbreviation is usually followed by FLG to make a difference.
- (4) The value and data registers usually include V, VALUE, D and DATA, which are not followed by verbs, such as: xxPSC and CNT.

1.2.2 Full Name and Abbreviation Description of Terms

Table 1 R/W Abbreviation and Description

R/W	Description	Abbreviation
read/write	Software can read and write this bit.	R/W
read-only	Software can only read this bit.	R
write-only	Software can only write this bit, and after reading this bit, the reset value will be returned.	W
read/clear	The software can read this bit and clear it by writing 1. Writing 0 has no effect on this bit.	RC_W1
read/clear	The software can read this bit and clear it by writing 0. Writing 1 has no effect on this bit.	RC_W0
read/clear by read	The software can read this bit, reading this bit will automatically clear it to 0, and writing this bit is invalid.	RC_R
read/set	The software can read and set this bit, and writing 0 has no effect on this bit.	R/S
read-only write trigger	The software can read this bit and writing 0 or 1 can trigger an event but has no effect on the value of this bit.	RT_W
toggle	The software can flip this bit only by writing 1 and writing 0 has no effect on this bit.	T

Table 2 Functional Description and Full Name and Abbreviation of Terms of Commonly Used Registers

Full name in English	English abbreviation
----------------------	----------------------

Full name in English	English abbreviation
Enable	EN
Disable	D
Clear	CLR
Select	SEL
Configure	CFG
Contrl	CTRL
Controller	C
Reset	RST
Stop	STOP
Set	SET
Load	LD
Calibration	CAL
Initialize	INIT
Error	ERR
Status	STS
Ready	RDY
Software	SW
Hardware	HW
Source	SRC
System	SYS
Peripheral	PER
Address	ADDR
Direction	DIR
Clock	CLK
Input	I
Output	O
Interrupt	INT
Data	DATA
Size	SIZE
Divider	DIV
Prescaler	PSC
Multiplier	MUL
Period	PRD

Table 3 Full Name and Abbreviation of Modules

Full name in English	English abbreviation
Reset and Clock Management	RCM
Clock Recovery System	CRS
Power Management Unit	PMU
Nested Vector Interrupt Controller	NVIC
External Interrupt /Event Controller	EINT
Direct Memory Access	DMA
Debug MCU	DBG MCU
General-Purpose Input Output Pin	GPIO
Alternate Function Input Output Pin	AFIO
Timer	TMR
Watchdog Timer	WDT
Independent Watchdog Timer	IWDT
Windows Watchdog Timer	WWDT
Real-Time Clock	RTC
Universal Synchronous Asynchronous Receiver Transmitter	USART
Inter-integrated Circuit Interface	I2C
Serial Peripheral Interface	SPI
Inter-IC Sound Interface	I2S
Controller Area Network	CAN
Universal Serial Bus Full-Speed Device	USBD
HDMI-CEC Controller	HDMI-CEC
Analog-to-Digital Converter	ADC
Digital-to-Analog Converter	DAC
Touch Sensing Controller	TSC
Comparator	COMP
Cyclic Redundancy Check Calculation Unit	CRC

2 System Architecture

2.1 Full Name and Abbreviation Description of Terms

Table 4 Full Name and Abbreviation Description of Terms

Full name in English	English abbreviation
Advanced High-Performance Bus	AHB
Advanced Peripheral Bus	APB

2.2 System Architecture Block Diagram

The main system mainly consists of two master modules and four slave modules. The main modules are Arm® Cortex®-M0+ core and general-purpose DMA (seven channels). The slave modules are internal SRAM, internal flash memory Flash, AHB2 bus connecting all GPIO ports, and AHB1/APB bridges on AHB1 bus, among which, AHB1/APB bridges connect all peripherals.

These are connected through a multi-level AHB bus architecture, as shown in the figure below:

Figure 1 APM32A072xBTx System Architecture Block Diagram

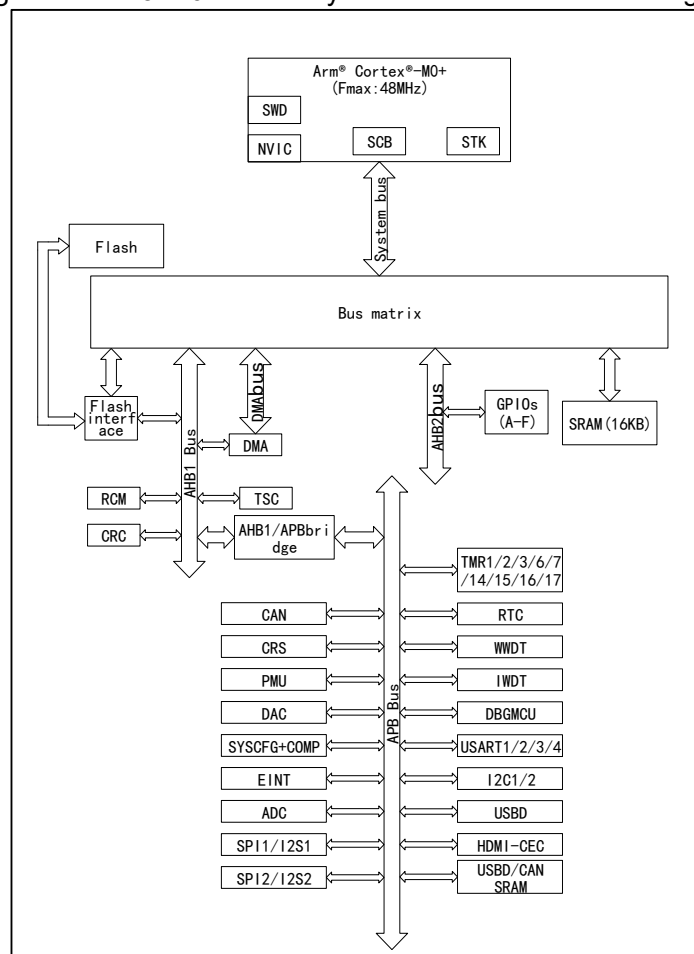

Table 5 Bus Name

Name	Instruction
System bus	Connect the system bus (peripheral bus) of Arm® Cortex® -M0 core and the bus matrix.
DMA bus	Connect AHB master control interface of DMA and the bus matrix.
Bus matrix	Coordinate the access of the core and DMA; consist of CPU AHB, system bus, DMA bus and FMC, SRAM, AHB2 and AHB1/APB bridge. AHB peripheral is connected with the system bus through the bus matrix and is allowed to access DMA.
AHB/APB bridge	The bridge provides synchronous connection between AHB and APB buses. The non-32-bit access to APB register will be converted into 32 bits automatically.

2.3 Memory Mapping

The memory mapping address is totally 4GB address. The assigned addresses include the core (including core peripherals), on-chip Flash (including main memory area, system memory area and option bytes), on-chip SRAM, and bus peripherals (including AHB and APB peripherals). Please refer to the data manual of the corresponding model for specific information of various addresses.

2.3.1 Embedded SRAM

Built-in static SRAM. It can access by byte, half word (16 bits) or full word (32 bits). The start address of SRAM is 0x2000 0000.

2.4 Startup Configuration

APM32A MCU series realizes a special mechanism. By configuring the BOOT pin parameter and the nBOOT1 bit in FMC_OBCS, there are three different startup modes, namely, the system can not only start from Flash memory or system memory, but also start from the built-in SRAM. The memory selected as the start zone is determined by the selected startup mode.

Table 6 Startup Mode Configuration and Access Mode

Startup mode configuration		Startup mode	Access mode
nBOOT1 bit	BOOT0 Pin		
X	0	Main flash memory (Flash)	The main flash memory is mapped to the boot space, but it can still be accessed at its original address, that is, the contents of the flash memory can be accessed in two address areas.
1	1	System memory	The system memory is mapped to the boot space (0x0000 0000), but it can still be accessed at its original address.
0	1	Built-in SRAM	SRAM can be accessed only at the starting address.

Note:

- (1) The boot space address is 0x0000 0000
- (2) The original address of Flash is 0x0800 0000
- (3) The original address of the system memory is 0x1FFF C800

- (4) The starting address of SRAM is 0x2000 0000
- (5) The user can select the startup mode after reset by setting the states of nBOOT1 bit and BOOT0 pin.
- (6) BOOT pin should keep the user's required startup configuration in standby mode. When exiting from the standby mode, the value of boot pin will be latched.
- (7) If you choose to start from built-in SRAM, you must use NVIC's exception table and offset register to remap the vector table to SRAM when writing the application code.

Physical remapping

After nBOOT1 bit and BOOT0 pin are selected, MMSEL bit of SYSCFG_CFG1 register can be modified through software program, and the accessed memory can be modified. See SYSCFG register for specific configuration.

Embedded startup program

The embedded startup program is written on the production line by Geehy and stored in the system memory area.

3 FLASH Memory

This manual is only applicable to APM32A072xBTx series products. It mainly introduces the memory structure, read, erase, write, read/write protection, unlock/lock characteristics of Flash, and the register function description involved.

3.1 Full Name and Abbreviation Description of Terms

Table 7 Full Name and Abbreviation Description of Terms

Full name in English	English abbreviation
Flash Memory Controller	FMC

3.2 Characteristics of Flash Memory

- (1) Flash memory structure
 - Contain main memory area and information block
 - The capacity of main memory area is up to 128KB
 - The information block is divided into system memory area and option byte
 - The capacity of the system memory area is 12KB, for storing BootLoader program, 96-bit unique UID, and main memory area capacity information
 - The capacity of the option byte area is 16Bytes
- (2) Functional Description
 - Read Flash
 - Page/Mass erase Flash
 - Write Flash
 - Read/Write protection Flash
 - Configure option bytes

3.3 Flash Memory Structure

Table 8 Flash Memory Structure of APM32A072xBTx Series Products

Block	Name	Address area	Size (byte)	Sector
Main memory area	Page 0	0x0800 0000–0x0800 07FF	2K	Sector 0
Main memory area	Page 1	0x0800 0800–0x0800 0FFF	2K	
Main memory area	
Main memory area	Page 62	0x0801 F000–0x0801 F7FF	2K	Sector 31
Main memory area	Page 63	0x0801 F800–0x0801 FFFF	2K	
Information block	System memory area	0x1FFF C800–0x1FFF F7FF	12K	-
Information block	Option byte	0x1FFF F800–0x1FFF F80F	16	-

Note: The number of pages (sectors) in the main memory block of APM32A072xBTx series products is related to the Flash capacity of specific product.

3.3.1 Main Memory Block

3.3.1.1 Erase main memory block

FMC supports page erase and mass erase (full erase) to initialize the contents of the main memory area to high level (the data is represented as 0xFFFF). Before writing to Flash, users are advised to erase the write address page. If the data of write address is not 0xFFFF, a programming error will be triggered.

Main memory page erase

Page erase is an independent erase according to the main memory area page selected by the program, which will not have any impact on the page not selected for erasure.

After the correct page erase (or flash write operation) is completed, OCF of FMC_STS register will be set. If OCIE interrupt is enabled, an operation completion interrupt will be triggered. Users need to note that the page to be erased must be a valid page (the valid address of the main memory area and the address not protected by write).

Main memory mass erase

The mass erase operation will erase all the contents in the main storage area of Flash, and the mass erase operation will erase all the data in the main memory area, so the users need to pay special attention when using it to avoid the loss of important data caused by misoperation.

3.3.1.2 Write main memory block

FMC supports the writing of 16-bit (half word) data in the main memory area. You can select Debug, BootLoader, program running in SRAM, and directly reading the erased page to judge whether the erasing is successful.

In order to ensure correct writing, it is necessary to check whether the destination address has been erased before writing; if it is not erased, the written data will be invalid and PEF bit of FMC_STS register will be set to "1". If the destination address has write protection, the written data is invalid and a write protection error will be triggered (WPEF bit of FMC_STS is set to "1").

3.3.1.3 Main memory block of read/write protection

Read/Write protection of the flash is used to prevent illegal reading/modification of the main memory area code or data, and it is controlled by the read/write protection configuration byte of option byte. For APM32A072xBTx series products, the basic unit of write protection is 2 pages (i.e. 4KB).

Read protection

The read protection has three levels, namely, Level 0, Level 1 and Level 2, which are specifically described as follows:

Table 9 Difference among Read Protection Levels

Category	READPROT	Description
Level 0	0xAA	The main memory area and option byte are erasable, writable and readable.
Level 1	Other values except 0xAA and 0xCC	User mode: Allowed to erase, write and read the main memory area and option byte. Debug, SRAM running, system memory area running: Access to the main memory area is disabled; the option byte is erasable, writable and readable, but when the level is modified to 0, the main memory area erase will be performed first.

Category	READPROT	Description
Level 2	0xCC	Debug is not allowed, the main memory area and option byte cannot be erased, written and read, and the level cannot be modified.

Write protection

Write protection control can be conducted for the corresponding page of the main memory block by configuring the value of write protection option byte WRP0/1/2/3. After the write protection is turned on, the content on the corresponding page of the main memory area cannot be modified in any way.

3.3.1.4 Main memory block of unlock/lock

FMC_CTRL1 of the reset FMC will be locked by hardware, and then FMC_CTRL1 can't be directly written, and the corresponding value must be written to FMC_KEY according to the correct sequence to unlock FMC. The KEY value is as follows:

- KEY1=0x45670123
- KEY2=0xCDEF89AB

The wrong writing sequence or wrong value will cause the program to enter the hardware wrongly. At this time, FMC will be locked, and all FMC operations will be invalid until it is reset next time. The users can also lock FMC through software by writing "1" to LOCK bit of the control register 2 (FMC_CTRL2).

In each Flash programming operation, the users must follow the steps of "Flash unlock - program by user - Flash lock", so as to avoid the risk that user code/data is accidentally modified due to the Flash unlocking after the Flash programming operation.

3.3.2 Option Byte

3.3.2.1 Erase option byte

Support erase function. After the correct option byte erase (or option byte write operation) is completed, OCF of FMC_STS register will be set. If OCIE interrupt is enabled, an operation completion interrupt will be triggered.

3.3.2.2 Write option byte

Eight configurable bytes of option bytes all support writing function.

3.3.2.3 Option byte of write protection

By default, the option byte is always readable and write protected. To perform write operation (program/erase) for the option byte block, first write the correct key sequence (the same as that of locking) in FMC_OBKEY, and then allow the write operation of option byte block; the OBWEN bit of FLASH_CTRL2 register indicates write enabled; clear this bit and write operation will be disabled.

3.3.2.4 Unlock/Lock option byte

After the system reset, the option byte is locked by default. Only when the option byte is unlocked correctly, can it be modified. The difference between option byte unlocking and flash unlocking is that FMC_OBKEY register rather than FMC_KEY register writes the KEY value. The option byte does not support "software lock". The user should pay special attention to that every time after the value of the option byte is modified, the system must be reset to make it effective.

3.3.3 Functional Description of Option Byte

The option byte provides some optional functions for users, and it mainly consists of 8 configurable bytes and corresponding complementary codes. Every time the system is reset, the option byte area will be reloaded to the FMC_OBCS and FMC_WRTPROT register (the option byte will only take effect each time they are reloaded to FMC). In the process of reloading, if a certain configurable byte does not match its reverse code, an option byte error (OBE bit of FMC_ register is set to "1") will be triggered, and this byte will be set to "0xFF". The information of 16 bytes in the option byte area is shown in the table below.

Table 10 Option Bytes

Address	Option byte	Initial value	R/W	Functional description
0x1FFF F800	READPROT	0xAA	R/W	Read protection configuration Bit [7:0]: READPROT 0xAA: Level 0 0xCC: Level 2 Others: Level 1
0x1FFF F801	nREADPROT	0x55	R	READPROT complementary code
0x1FFF F802	UOB	0xFF	R/W	User option byte Bit 0: WDTSEL 0: Hardware watchdog 1: Software watchdog Bit 1: nRSTSTOP 0: Reset occurs when entering the Stop mode 1: Reset does not occur when entering the Stop mode Bit 2: nRSTSTB 0: Reset occurs when entering the Standby mode 1: Reset does not occur when entering the Standby mode Bit 3: Reserved Bit 4: nBOOT1 Select BOOT mode Bit 5: VDDA_MONITOR 0: V _{DDA} power supply detector is disabled 1: V _{DDA} power supply detector is enabled Bit 6: RAM_PARITY_CHECK 0: RAM parity check is disabled 1: RAM parity check is enabled Bit 7: Reserved
0x1FFF F803	nUOB	0x00	R	UOB complementary code
0x1FFF F804	Data0	0xFF	R/W	User data byte 0
0x1FFF F805	nData0	0x00	R	Data0 complementary code
0x1FFF F806	Data1	0xFF	R/W	User data byte 1
0x1FFF F807	nData1	0x00	R	Data complementary code
0x1FFF F808	WRP0	0xFF	R/W	Write protection configuration 0
0x1FFF F809	nWRP0	0x00	R	WRP0 complementary code
0x1FFF F80A	WRP1	0xFF	R/W	Write protection configuration 1
0x1FFF F80B	nWRP1	0x00	R	WRP1 complementary code
0x1FFF F80C	WRP2	0xFF	R/W	Write protection configuration 2

Address	Option byte	Initial value	R/W	Functional description
0x1FFF F80D	nWRP2	0x00	R	WRP2 complementary code
0x1FFF F80E	WRP3	0xFF	R/W	Write protection configuration 3
0x1FFF F80F	nWRP3	0x00	R	WRP3 complementary code

Note: When the configurable byte and its reverse code value are "0xFF", the match will not be verified in the reloading process

Table 11 Write Protection WRPx Function Description of Main Memory Area

Product capacity	Functional description
APM32A072xB series products	<p>Each bit in WRPx controls the write protection of 4KB (2 pages) address of the main memory area</p> <p>0: Write protection is turned on</p> <p>1: Write protection is not turned on</p> <p>WRP0: Page 0-15</p> <p>WRP1: Page 16-31</p> <p>WRP2: Page 32-63</p>

Note: Flash read/write protection configuration is independent of each other. Removing the write protection will not force the loss of the contents of the main memory area, but keep them as they are.

3.4 Register Address Mapping

Base address: 0x40022000

Table 12 FMC Register Address Mapping

Register name	Description	Offset address
FMC_CTRL1	Control register 1	0x00
FMC_KEY	Key register	0x04
FMC_OBKEY	Option byte key register	0x08
FMC_STS	State register	0x0C
FMC_CTRL2	Control register 2	0x10
FMC_ADDR	Address register	0x14
FMC_OBCS	Option byte control/state register	0x1C
FMC_WRTPROT	Write protection register	0x20

3.5 Register Functional Description

3.5.1 Control register 1 (FMC_CTRL1)

Offset address: 0x00

Reset value: 0x0000 0000

Field	Name	R/W	Description
-------	------	-----	-------------

Field	Name	R/W	Description
2:0	WS	R/W	Wait State Configure 000: 0 wait cycle, 0<system clock≤24MHz 001: 1 wait cycle: 24MHz<system clock≤48MHz Others: Reserved
3	Reserved		
4	PBEN	R/W	Prefetch Buffer Enable 0: Disable 1: Enable
5	PBSF	R	Prefetch Buffer Status Flag 0: In disabled state 1: In enabled state
31:6	Reserved		

3.5.2 Key register (FMC_KEY)

Offset address: 0x04

Reset value: 0xXXXX XXXX

Field	Name	R/W	Description
31:0	KEY	W	FMC Key Writing the keys represented by these bits can unlock FMC. These bits can only perform write operation, and 0 is returned when read operation is performed.

3.5.3 Option byte key register (FMC_OBKEY)

Offset address: 0x08

Reset value: 0xXXXX XXXX

Field	Name	R/W	Description
31:0	OBKEY	W	Option Byte Key Writing the keys represented by these bits can unlock the option byte write operation. These bits can only perform write operation and 0 is returned when read operation is performed.

3.5.4 State register (FMC_STS)

Offset address: 0x0C

Reset value: 0x0000 0000

Field	Name	R/W	Description
0	BUSYF	R	Busy Flag This bit indicates that a flash operation is in progress. These bits can only perform write operation, and 0 is returned when read operation is performed.
1	Reserved		
2	PEF	R/W	Programming Error Flag This bit will be set by software when the value before the address is edited is not "0xFFFF".
3	Reserved		
4	WPEF	R/W	Write Protection Error Flag This bit will be set by hardware when programming the write protection address in FLASH.

Field	Name	R/W	Description
5	OCF	R/W	Operation Complete Flag This bit will be set by hardware when read/write operation in FLASH is completed.
31:6	Reserved		

3.5.5 Control register 2 (FMC_CTRL2)

Offset address: 0x10

Reset value: 0x0000 0080

Field	Name	R/W	Description
0	PG	R/W	Program Set this bit to 1 to program Flash
1	PAGEERA	R/W	Page Erase Set this bit to 1 to erase the page
2	MASSERA	R/W	Mass Erase Set this bit to 1 to erase the mass.
3	Reserved		
4	OBP	R/W	Option Byte Program Set this bit to 1 to program the option byte.
5	OBE	R/W	Option Byte Erase Set this bit to 1 to erase the option byte.
6	STA	R/W	Start Erase This bit can be only set to 1 by software, and can be reset by clearing BUSYF bit of FMC_STS.
7	LOCK	R/W	Lock This bit can be written to 1 only, and when this bit is set to 1, it means that FMC and CTRL2 registers are locked.
8	Reserved		
9	OBWEN	R/W	Option Byte Write Enable When this bit is set to 1, the option byte can be programmed.
10	ERRIE	R/W	Error interrupt Enable 0: Interrupt is disabled 1: Interrupt is enabled When PEF=1 for FMC_STS or WPEF=1 for FMC_STS, set this bit to generate an interrupt.
11	Reserved		
12	OCIE	R/W	Operation Complete Interrupt Enable 0: Operation completion interrupt is disabled 1: Operation completion interrupt is enabled When OCF=1 for FMC_STS, set this bit to generate an interrupt.
13	OBLOAD	R/W	Force Option Byte Load When this bit is set to 1, force to reload the option byte to generate system reset. 0: Idle 1: Force to load
31:14	Reserved		

3.5.6 Address register (FMC_ADDR)

Offset address: 0x14

Reset value: 0x0000 0000

The register is changed to currently/finally used address by hardware; in page erasing, the register needs to be configured by software.

Field	Name	R/W	Description
31:0	ADDR	W	Flash Address In programming operation, the bit is written to the address to be programmed; in page erasing, this bit is written to the page to be erased.

3.5.7 Option byte control/state register (FMC_OBCS)

Offset address: 0x1C

Reset value: 0xFFFF XX0X

The reset value of the register is related to the value in the written option byte; the reset value of OBE bit is related to the result whether the value of the loaded option byte is consistent with its reverse code.

Field	Name	R/W	Description
0	OBE	R	Option Byte Error 1: The loaded option byte does not match its complementary code. The option byte and its complementary code are forced to write to 0xFF
2:1	READPROT	R	Read Protect Indicate which level of read protection was enabled. If bit1 is set to 1, it is level 1. If bit2 is set to 1, it is level 2. 00: Level 0 01: Level 1 1X: Level 2
7:3	Reserved		
8	WDTSEL	R	Watchdog Select 0: Hardware watchdog 1: Software watchdog
9	RSTSTOP	R	nReset in STOP Mode 0: Generate 1: Not generate
10	RSTSTDB	R	nReset in STANDBY Mode 0: Generate 1: Not generate
11	Reserved		
12	nBOOT1	R	nBoot1 Mode Configure
13	VDDAMONI	R	V _{DDA} Monitor
14	SRAMPARITY	R	SRAM Parity Check
15	Reserved		
23:16	DATA0	R	Data0
31:24	DATA1	R	Data1

3.5.8 Write protection register (FMC_WRTPROT)

Offset address: 0x20

Reset value: 0xXXXX XXXX (the reset value depends on the programming value in option byte)

Field	Name	R/W	Description
31:0	WRTPROT	R	Write Protect Each bit protects two pages. See Table 11 for details. 0: Valid 1: Invalid

4 System Configuration Controller (SYSCFG)

4.1 Full Name and Abbreviation Description of Terms

Table 13 Full Name and Abbreviation Description of Terms

Full name in English	English abbreviation
Fast Mode Plus	FM+
System Configure Controller	SYSCFG

SYSCFG is mainly used to manage address mapping and control interrupts, specifically: controlling the fast mode plus of I2C on some IO ports; configuring DMA trigger source remapping; remapping from memory to code start area; and managing the external interrupts connected to GPIO.

For details of related configuration, see SYSCFG register configuration.

4.2 Register Address Mapping

Table 14 SYSCFG Register Address Mapping

Register name	Description	Offset address
SYSCFG_CFG1	Configuration register 1	0x00
SYSCFG_EINTCFG1	External interrupt register 1	0x08
SYSCFG_EINTCFG2	External interrupt register 2	0x0C
SYSCFG_EINTCFG3	External interrupt register 3	0x10
SYSCFG_EINTCFG4	External interrupt register 4	0x14
SYSCFG_CFG2	Configuration register 2	0x18

4.3 Register Functional Description

4.3.1 Configuration register 1 (SYSCFG_CFG1)

Offset address: 0x00

Reset value: 0x0000 000X (X means memory mode, controlled by BOOT. After reset, these bits select the mode configuration parameters through BOOT pin.)

This register is used to configure the memory and DMA requested remapping and control the specific I/O pins.

All of these bits can skip the hardware to have the software to select the physical mapping, and can be controlled and reset by software.

Field	Name	R/W	Description
1:0	MMSEL	R/W	Memory Mapping Select Control the memory mapping address 0x0000 0000. After reset, the parameters of these bits are determined by actual BOOT. X0: Main flash mapping address: 0x0000 0000 01: System flash mapping address: 0x0000 0000 11: Embedded SRAM mapping address: 0x0000 0000

Field	Name	R/W	Description
7:2	Reserved		
8	ADCDMARMP	R/W	ADC DMA Request Remap Control remapping request of ADC DMA. 0: No remapping ADC—DMA_CH1 1: Remapping ADC—DMA_CH2
9	USART1TXRMP	R/W	USART1_TX DMA Request Remap This bit controls remapping request of USART1_TX DMA. 0: No remapping USART1_RX—DMA_CH2 1: Remapping USART1_RX—DMA_CH4
10	USART1RXRMP	R/W	USART1_RX DMA Request Remap This bit controls remapping request of USART1_RX DMA. 0: No remapping USART1_TX—DMA_CH3 1: Remapping USART1_TX—DMA_CH5
11	TMR16DMARMP	R/W	TMR16 DMA Request Remap This bit controls remapping request of TMR16 DMA. 0: No remapping TMR16_CH1 and TMR16_UP—DMA_CH3 1: Remapping TMR16_CH1 and TMR16_UP—DMA_CH4
12	TMR17DMARMP	R/W	TMR17 DMA Request Remap This bit control remapping request of TMR17. 0: No remapping TMR17_CH1 and TMR17_UP—DMA_CH1 1: Remapping TMR17_CH1 and TMR17_UP—DMA_CH2
13	TMR16DMARMP2	R/W	TMR16 Alternate DMA Remap Request If there is no request for remapping to other DMA channels, remapping is performed according to TMR16DMARMP bit. 0: No other remapping 1: Remapping TMR16_CH1 and TMR16_UP—DMA_CH6
14	TMR17DMARMP2	R/W	TMR17 Alternate DMA Remap Request If there is no request for remapping to other DMA channels, remapping is performed according to TMR17DMARMP bit. 0: No other remapping 1: Remapping TMR17_CH1 and TMR17_UP—DMA_CH7
15	Reserved		
16	I2CPB6FMP	R/W	Fast Mode Plus Driving Capability Activate for PB6 This bit enables PB6 interface to enable I2C fast mode plus. 0: PB6 pin is set as standard mode. 1: PB6 pin is set as I2C fast mode plus and I2C speed control is bypassed (ignored).
17	I2CPB7FMP	R/W	Fast Mode Plus Driving Capability Activate for PB7 This bit enables PB7 interface to enable I2C fast mode plus.

Field	Name	R/W	Description
			0: PB7 pin is set as standard mode. 1: PB7 pin is set as I2C fast mode plus and I2C speed control is bypassed (ignored).
18	I2CPB8FMP	R/W	Fast Mode Plus Driving Capability Activate for PB8 This bit enables PB8 interface to enable I2C fast mode plus. 0: PB8 pin is set as standard mode. 1: PB8 pin is set as I2C fast mode plus and I2C speed control is bypassed (ignored).
19	I2CPB9FMP	R/W	Fast Mode Plus Driving Capability Activate for PB9 This bit enables PB9 interface to enable I2C fast mode plus. 0: PB9 pin is set as standard mode. 1: PB9 pin is set as I2C fast mode plus and I2C speed control is bypassed (ignored).
20	I2C1FMP	R/W	FM+ Driving Capability Activate for I2C1 0: The fast mode plus is only controlled by I2CPxxFM+ bit. 1: All pins of I2C1 can be selected for fast mode plus by GPIO_AFx.
21	I2C2FMP	R/W	FM+ Driving Capability Activate for I2C1 0: The fast mode plus is only controlled by I2CPxxFM+ bit. 1: All pins of I2C2 can be selected for fast mode plus by GPIO_AFx.
23:22	Reserved		
24	SPI2DMARMP	R/W	SPI2 DMA Request Remap This bit controls remapping request of SPI2 DMA. 0: No remapping SPI2_RX—DMA_CH4 SPI2_TX—DMA_CH5 1: Remapping SPI2_RX—DMA_CH6 SPI2_TX—DMA_CH7
25	USART2DMARMP	R/W	USART2 DMA Request Remap This bit controls remapping request of USART2 DMA. 0: No remapping USART 2_RX—DMA_CH5 USART 2_TX—DMA_CH4 1: Remapping USART 2_RX—DMA_CH6 USART 2_TX—DMA_CH7
26	USART3DMARMP	R/W	USART3 DMA Request Remap This bit controls remapping request of USART3 DMA. 0: No remapping USART3_RX—DMA_CH6 USART3_TX—DMA_CH7 1: Remapping USART3_RX—DMA_CH3 USART3_TX—DMA_CH2
27	I2C1DMARMP	R/W	I2C1 DMA Request Remap This bit controls remapping request of I2C1 DMA. 0: No remapping I2C1_RX—DMA_CH3 I2C1_TX—DMA_CH2 1: Remapping

Field	Name	R/W	Description
			I2C1_RX—DMA_CH7 I2C1_TX—DMA_CH6
28	TMR1DMARMP	R/W	TMR1 DMA Request Remap This bit controls remapping request of TMR1 DMA. 0: No remapping TMR1_CH1—DMA_CH2 TMR1_CH2—DMA_CH3 TMR1_CH3—DMA_CH4 1: Remapping TMR1_CH1, TMR1_CH2 and TMR1_CH3—DMA_CH6
29	TMR2DMARMP	R/W	TMR2 DMA Request Remap This bit controls remapping request of TMR2 DMA. 0: No remapping TMR2_CH2—DMA_CH3 TMR2_CH4—DMA_CH4 1: Remapping TMR2_CH2 and TMR2_CH4—DMA_CH7
30	TMR3DMARMP	R/W	TMR3 DMA Request Remap This bit controls remapping request of TMR3 DMA. 0: No remapping TMR3_CH1 and TMR3_TRIG—DMA_CH4 1: Remapping TMR3_CH1 and TMR3_TRIG—DMA_CH6
31	Reserved		

4.3.2 External interrupt register 1 (SYSCFG_EINTCFG1)

These bits are controlled by software to be rewritten to select the external interrupt source of EINTx(x=0...3). The selected external interrupt sources represented by values of the EINTx [3:0] are shown in the table below.

Table 15 External Interrupt Sources Selected for Different Values

EINTx [3:0]	External interrupt source
x000	PA[x] pin
x001	PB[x] pin
x010	PC[x] pin
x011	PD[x] pin
x100	PE[x] pin
x101	PF[x] pin
Others	Reserved

Offset address: 0x08

Reset value: 0x0000 0000

Field	Name	R/W	Description
3:0	EINT0	R/W	EINT0 Configure These bits are controlled by software to be rewritten to select the external interrupt source of EINT0.

Field	Name	R/W	Description
			The selected external interrupt sources represented by values of the bits are shown in Table 15
7:4	EINT1	R/W	EINT1 Configure These bits are controlled by software to be rewritten to select the external interrupt source of EINT1. The selected external interrupt sources represented by values of the bits are shown in Table 15
11:8	EINT2	R/W	EINT2 Configure These bits are controlled by software to be rewritten to select the external interrupt source of EINT2. The selected external interrupt sources represented by values of the bits are shown in Table 15.
15:12	EINT3	R/W	EINT3 Configure These bits are controlled by software to be rewritten to select the external interrupt source of EINT3. The selected external interrupt sources represented by values of the bits are shown in Table 15.
31:16	Reserved		

4.3.3 External interrupt register 2 (SYSCFG_EINTCFG2)

These bits are controlled by software to be rewritten to select the external interrupt source of EINT_x(x=4...7). The selected external interrupt sources represented by values of the EINT_x [3:0] are shown in Table 15.

Offset address: 0x0C

Reset value: 0x0000 0000

Field	Name	R/W	Description
3:0	EINT4	R/W	EINT4 Configure These bits are controlled by software to be rewritten to select the external interrupt source of EINT4. The selected external interrupt sources represented by values of the bits are shown in Table 15.
7:4	EINT5	R/W	EINT5 Configure These bits are controlled by software to be rewritten to select the external interrupt source of EINT5. The selected external interrupt sources represented by values of the bits are shown in Table 15.
11:8	EINT6	R/W	EINT6 Configure These bits are controlled by software to be rewritten to select the external interrupt source of EINT6. The selected external interrupt sources represented by values of the bits are shown in Table 15.
15:12	EINT7	R/W	EINT7 Configure These bits are controlled by software to be rewritten to select the external interrupt source of EINT7. The selected external interrupt sources represented by values of the bits are shown in Table 15.
31:16	Reserved		

4.3.4 External interrupt register 3 (SYSCFG_EINTCFG3)

These bits are controlled by software to be rewritten to select the external interrupt source of EINT_x(x=8...11). The selected external interrupt sources

represented by values of the EINTx [3:0] are shown in Table 15.

Offset address: 0x10

Reset value: 0x0000 0000

Field	Name	R/W	Description
3:0	EINT8	R/W	EINT8 Configure These bits are controlled by software to be rewritten to select the external interrupt source of EINT8. The selected external interrupt sources represented by values of the bits are shown in Table 15.
7:4	EINT9	R/W	EINT9 Configure These bits are controlled by software to be rewritten to select the external interrupt source of EINT9. The selected external interrupt sources represented by values of the bits are shown in Table 15.
11:8	EINT10	R/W	EINT10 Configure These bits are controlled by software to be rewritten to select the external interrupt source of EINT10. The selected external interrupt sources represented by values of the bits are shown in Table 15.
15:12	EINT11	R/W	EINT11 Configure These bits are controlled by software to be rewritten to select the external interrupt source of EINT11. The selected external interrupt sources represented by values of the bits are shown in Table 15.
31:16	Reserved		

4.3.5 External interrupt register 4 (SYSCFG_EINTCFG4)

These bits are controlled by software to be rewritten to select the external interrupt source of EINTx(x=12 to 15). The selected external interrupt sources represented by values of the EINTx [3:0] are shown in Table 15.

Offset address: 0x14

Reset value: 0x0000 0000

Field	Name	R/W	Description
3:0	EINT12	R/W	EINT12 Configure These bits are controlled by software to be rewritten to select the external interrupt source of EINT12. The selected external interrupt sources represented by values of the bits are shown in Table 15.
7:4	EINT13	R/W	EINT13 Configure These bits are controlled by software to be rewritten to select the external interrupt source of EINT13. The selected external interrupt sources represented by values of the bits are shown in Table 15.
11:8	EINT14	R/W	EINT14 Configure These bits are controlled by software to be rewritten to select the external interrupt source of EINT14. The selected external interrupt sources represented by values of the bits are shown in Table 15.
15:12	EINT15	R/W	EINT15 Configure These bits are controlled by software to be rewritten to select the external interrupt source of EINT15. The selected external interrupt sources represented by values of the bits are shown in Table 15.
31:16	Reserved		

4.3.6 Configuration register 2 (SYSCFG_CFG2)

Offset address: 0x18

Reset value: 0x0000 0000

Field	Name	R/W	Description
0	LOCK	R/W	Core LOCKUP Enable This bit is set by software and cleared by system reset. It can enable and lock the connection between Arm® Cortex®-M0+ LOCKUP Hardfault (hardware error) output and TMR1/15/16/17 break input.
1	SRAMLOCK	R/W	SRAM Parity Check Lock This bit is set by software and is cleared by system reset. Can enable and lock the connection between SRAM parity error signal and TMR1/15/16/17 break input.
2	PVDLOCK	R/W	PVD Lock Enable It can enable and lock the connection between PVD interrupt and TMR1/15/16/17 break input and lock the states of PVDEN bit and PLSEL bit in PMU_CTRL. 0: Connection locked; PVDEN bit and PLSEL bit are editable 1: Connection enabled; PVDEN bit and PLSEL bit are read-only
7:3	Reserved		
8	SRAMEFLG	RC_W1	SRAM Parity Error Flag When an SRAM parity error is detected, this bit will be set by hardware. This bit will be cleared when the software writes "1". 0: No SRAM parity check bit error is detected 1: SRAM parity check bit error
31:9	Reserved		

5 Reset and Clock Management (RCM)

5.1 Full Name and Abbreviation Description of Terms

Table 16 Full Name and Abbreviation Description of Terms

Full name in English	English abbreviation
Reset and Clock Management	RCM
Reset	RST
Power-On Reset	POR
Power-Down Reset	PDR
High Speed External Clock	HSECLK
Low Speed External Clock	LSECLK
High Speed Internal Clock	HSICKL
Low Speed Internal Clock	LSICKL
Phase Locked Loop	PLL
Main clock output	MCO
Calibrate	CAL
Trim	TRM
Clock Recovery System	CRS
Clock Security System	CSS
Non Maskable Interrupt	NMI

5.2 Reset Functional Description

The supported reset is divided into three forms, namely, system reset, power reset and backup domain reset.

5.2.1 System Reset

5.2.1.1 "System reset" reset source

The reset source is divided into external reset source and internal reset source.

External reset source:

- Low level on NRST pin.

Internal reset source:

- Window watchdog termination count (WWDT reset)
- Independent watchdog termination count (IWDT reset)
- Software reset (SW reset)

- Low-power management reset
- Load option byte reset
- One power reset

A system reset will occur in case of any of the above events. Besides, the reset event source can be identified by viewing the reset flag bit in RCM_CSTS (control/state register).

When the system is reset, all registers except the registers in RCM_CSTS (control/state register) reset flag bit and backup domain area (see the power supply control block diagram) will be reset to the reset state.

Software reset

Software can be reset by putting SYSRESETREQ in Arm® Cortex®-M0+ interrupt application and reset control register to "1".

Low-power management reset

Low-power management may reset in two cases, one is when entering the standby mode, and the other is when entering the stop mode. In these two cases, if RSTSTDBY (in standby mode) or RSTSTOP (in stop mode) in user selection byte is set to "1", the system will be reset rather than entering the standby or stop mode.

For more information about user option bytes, refer to the chapter of "Flash memory".

Load option byte reset

The load byte reset is triggered by OBLOAD bit in FMC_CTRL2 register which is controlled by software.

5.2.1.2 "System Reset" reset circuit

The reset source is used in the NRST pin, which remains low in reset process.

The internal reset source generates a delay of at least 20μs pulse on the NRST pin through the pulse generator, which causes the NRST to maintain the level to generate reset; the external reset source directly pulls down the NRST pin level to generate reset.

The "system reset" reset circuit is shown in the figure below.

Figure 2 "System Reset" Reset Circuit

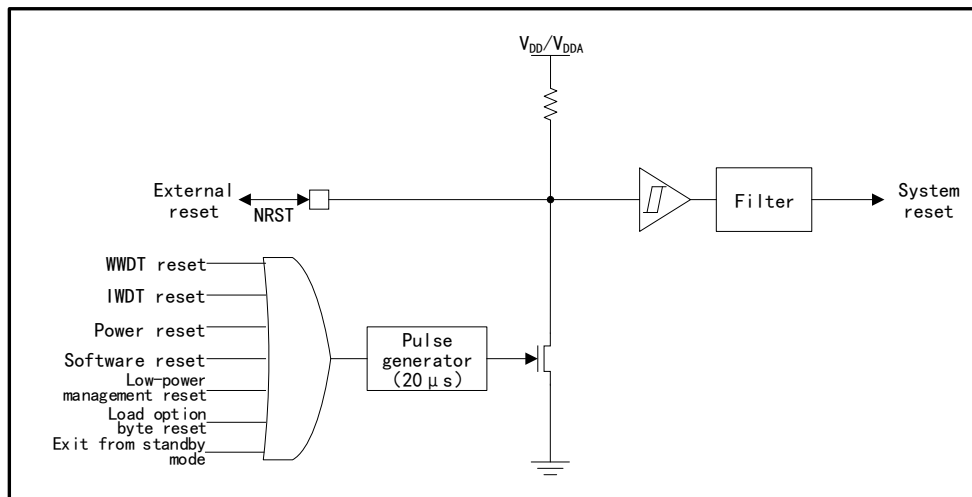

5.2.2 Power Reset

"Power reset" reset source is as follows:

- Power-on (POR reset)
- Power-down reset (PDR reset)
- Wake up from standby mode

A power reset will occur in case of any of the above events. Power reset will reset all registers except that in RTC area.

5.2.3 Backup Domain Reset

"Backup domain reset" reset source is as follows:

- Software sets the BDRST bit in RCM_BDCTRL (backup domain control register)
- V_{DD} is powered on because V_{BAT} cannot be connected after power-down

A backup domain reset will occur in case of any of the above events. The backup area reset has two special resets, which only affect backup area. The backup domain register can also be reset through any of the following events:

- RTC modification detected
- Read protection level changed from Level 1 to Level 0

5.3 Functional Description of Clock Management

The clock sources of the whole system are: HSECLK, LSECLK, HSICLK, HSICLK48, HSICLK14, LSICLK and PLL. For the characteristics of the clock source, please refer to the relevant chapter of "Electrical Characteristics" in the data manual.

5.3.1 External Clock Source

The external clock signal includes HSECLK (high-speed external clock signal) and LSECLK (low-speed external clock signal).

There are two kinds of external clock sources:

- External crystal/ceramic resonator
- External clock of user

The hardware configuration of the two kinds of clock sources is shown in the figure below.

Figure 3 HSECLK/LSECLK Clock Source Hardware Configuration

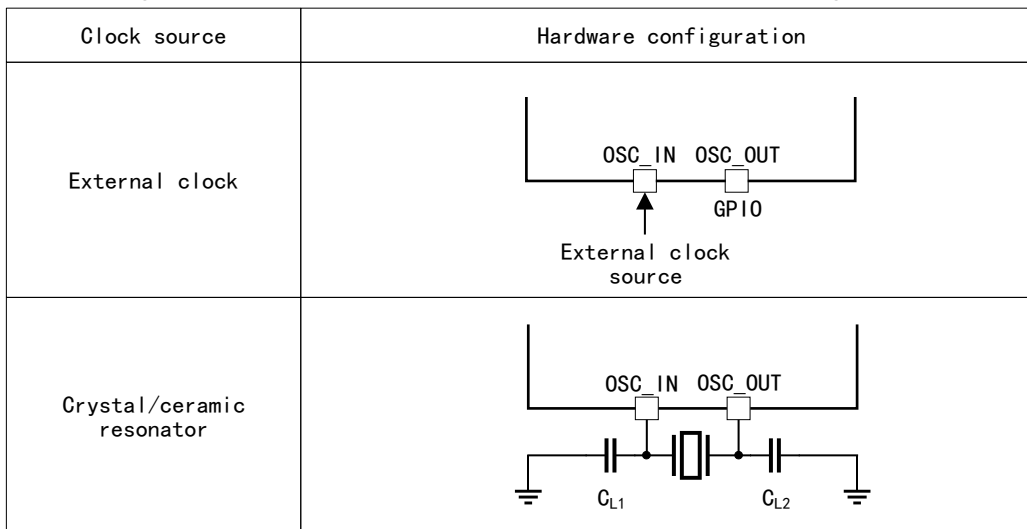

In order to reduce the distortion of clock output and shorten the start-up stabilization time, the crystal/ceramic resonator and load capacitor must be as close to the oscillator pin as possible. The value of load capacitance (C_{L1} , C_{L2}) must be adjusted according to the selected oscillator.

5.3.1.1 HSECLK high-speed external clock signal

HSECLK clock signal is generated by HSECLK external crystal/ceramic resonator and HSECLK external clock two kinds of clock sources.

Table 17 Clock Source Generating HSECLK

Name	Instruction
External clock source (HSECLK bypass)	<p>Provide clock to MCU through OSC_IN pin.</p> <p>The signal can be generated by ordinary function signal transmitter (in debugging), crystal oscillator and other signal generators; the waveform can be square wave, sine wave or triangle wave with 40%-60% duty cycle, and the maximum frequency is up to 32MHz.</p> <p>For hardware connection, it should be connected to OSC_IN pin, ensuring OSC_OUT pin is suspended; for MCU configuration, the user can select this mode by setting HSEBCFG and HSEEN bits in RCM_CTRL1 (clock control register 1).</p>
External crystal/ceramic resonator (HSECLK crystal)	<p>The clock is provided to MCU by the resonator, and the resonator includes crystal resonator and ceramic resonator.</p> <p>The frequency range is 4-32MHz.</p> <p>When needing to connect OSC_IN and OSC_OUT to the resonator, it can be enabled and disabled by setting the HSEEN bit in clock control register RCM_CTRL1 (clock control register).</p> <p>HSERDYFLG bit in the clock control register RCM_CTRL1 (clock control register 1) is used to indicate whether the high-speed external oscillator is stable. After startup, the clock is not released until this bit is set to "1" by hardware. If interrupt is allowed in RCM_INT (clock interrupt register), corresponding interrupt will be generated.</p>

5.3.1.2 LSECLK low-speed external clock signal

LSECLK clock signal is generated by LSECLK external crystal/ceramic resonator and LSECLK external clock two kinds of clock sources.

Table 18 Clock Source Generating LSECLK

Name	Instruction
External clock source (LSECLK bypass)	<p>The clock is provided to MCU through OSC32_IN pin. The signal can be generated by ordinary function signal transmitter (in debugging), crystal oscillator and other signal generators; the waveform can be square wave, sine wave or triangle wave with 50% duty cycle, and the signal frequency needs to be 32.768kHz. For hardware connection, it must be connected to OSC32_IN pin, ensuring OSC32_OUT pin is suspended; for MCU configuration, the user can select this mode by setting LSEBCFG and LSEEN bits in RCM_BDCTRL.</p>
External crystal/ceramic resonator (LSECLK crystal)	<p>The clock is provided to MCU by the resonator, and the resonator includes crystal resonator and ceramic resonator. The frequency is 32.768kHz. OSC32_IN、OSC32_OUT needs to be connected to the oscillator which can be enabled and disabled through LSEEN bit in RCM_BDCTRL. LSEIRDYFLG in RCM_BDCTRL indicates whether LSECLK crystal oscillator is stable. At startup stage, LSECLK clock signal is not released until this bit is set to "1" by hardware. If it is allowed in the clock interrupt register, an interrupt request can be generated.</p>

5.3.2 Internal Clock Source

The internal clock includes HSICLK (high-speed internal clock signal) and LSICLK (low-speed internal clock signal).

5.3.2.1 HSICLK high-speed internal clock signal

HSICLK clock signal is generated by internal 8MHz RC oscillator.

The RC oscillator frequency of different chips is different, and that of the same chip may be different with the change of temperature and voltage; the HSICLK clock frequency of each chip has been calibrated to 1% (25°C, $V_{DD}=V_{DDA}=3.3V$) by the manufacturer before leaving the factory. When the system is reset, the value calibrated by the manufacturer will be loaded to RCM_CTRL1 (clock control register); in addition, the users can further adjust the frequency by setting HSITRM in RCM_CTRL1 according to the application environment (temperature and voltage) of the site.

HSIRDYFLG bit can be used to indicate whether HSICLK RC oscillator is stable. In the clock startup process, HSICLK RC output clock is not released until the HSIRDYFLG bit is set to "1" by hardware. HSICLK RC oscillator can be enabled or disabled by HSIEN bit in RCM_CTRL1.

Compared with HSECLK crystal oscillator, RC oscillator can provide system clock without any external device; the start time of RC oscillator is shorter than that of HSECLK crystal oscillator; even after calibration, its clock frequency accuracy is still inferior to that of HSECLK crystal oscillator.

5.3.2.2 HSICLK48 high-speed internal clock signal

HSICLK48 clock signal is generated by internal 48MHz RC oscillator.

Main functions:

- Provide 48MHz high-precision clock signal for USBD through CRS. If there is no CRS, HSICLK48 accuracy will be biased
- When the system is in run mode, it can provide clock signal for the system; once the system is in stop or standby mode, it will stop providing signals
- As one of clock sources of MCO

HSI48RDYFLG bit can be used to indicate whether HSICLK48 RC oscillator is stable. In the clock startup process, HSICLK48 is not released until the HSI48RDFLG bit is set to 1 by hardware. HSICLK48 RC can be started or closed by HSI48EN bit in RCM_CTRL2. When it is selected as USBD clock signal supply, HSI48EN bit will be set to "1" by hardware and be enabled by USBD peripheral.

5.3.2.3 LSICLK low-speed internal clock signal

Main characteristics of LSICLK

LSICLK is generated by RC oscillator, within the range of 40kHz (30kHz and 60kHz). The frequency may change along with the change of temperature and voltage. The clock can be provided to IWDG (independent watchdog) and RTC (real-time clock) when keeping running in stop and standby mode.

LSICLK can be enabled or disabled by LSIEN bit of RCM_CSTS (control/state register). LSIRDYFLG bit in RCM_CSTS indicates whether the low-speed internal oscillator is stable. At startup stage, the clock is not released until this bit is set to "1" by hardware. If it is allowed in RCM_INT (clock interrupt register), LSICLK interrupt request will be generated.

5.3.3 PLL (Phase Locked Loop)

The internal PLL can be used to double the frequency of HSICLK output clock or HSECLK crystal output clock.

To configure PLL parameters, first clear PLEN bit, and after PLLRDYFLG is cleared (PLL is in the disabled state), change the parameters, then set PLEN to 1, and by enabling PLL, when PLLRDYFLG is set to 1, the configuration is completed.

The clock source and multiplication factor should be selected before being activated. Once PLL is activated, the selection cannot be changed.

When PLL is ready and PLL interrupt in RCM_INT is allowed, PLL can transmit interrupt request.

5.3.4 Clock Tree

APM32A072xBTx clock tree is shown in the figure below:

Figure 4 APM32A072xBTx Clock Tree

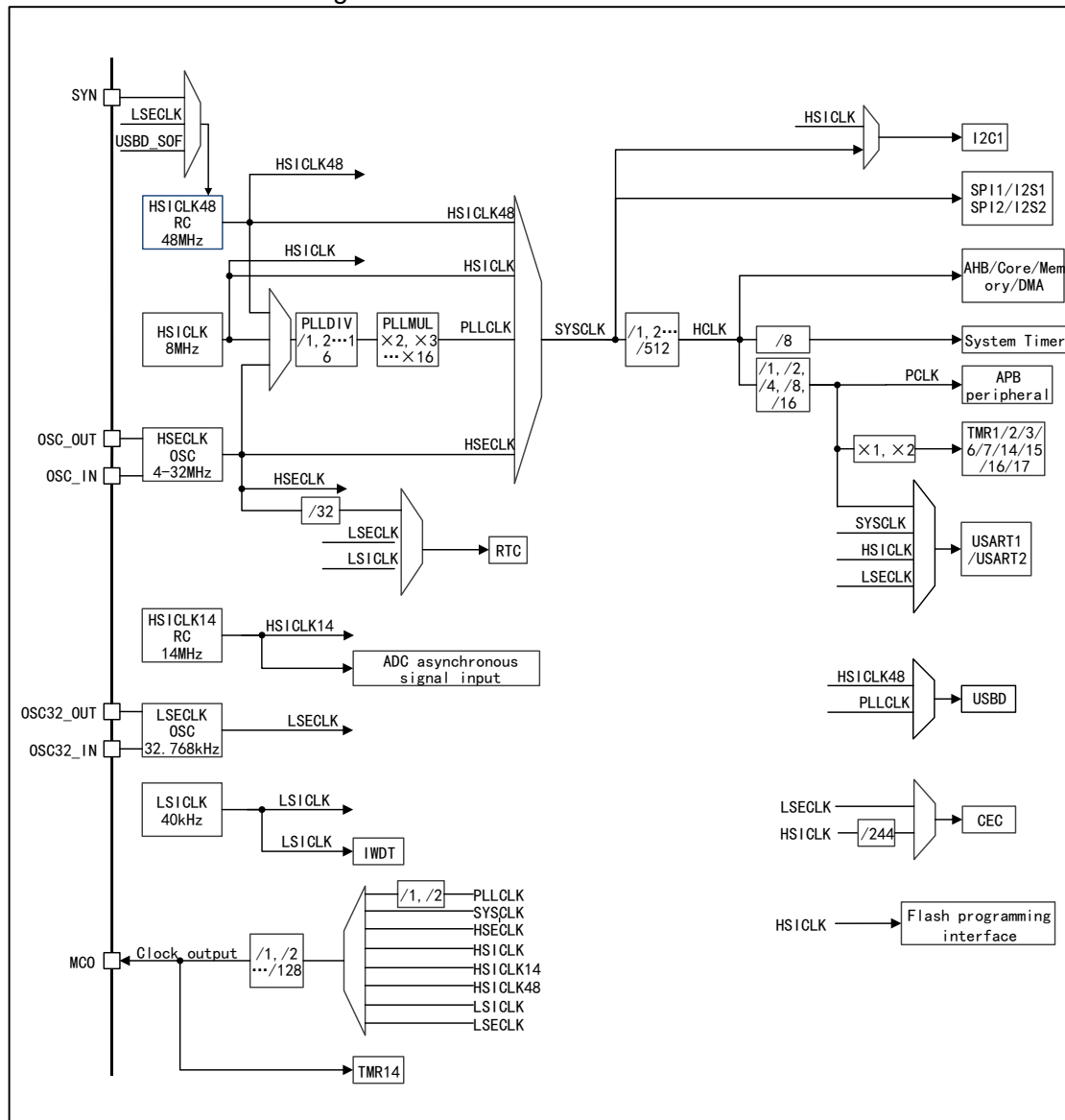

Note:

- (1) HCLK means AHB clock.
- (2) PCLK is clock signal of the peripheral connected to APB.
- (3) FCLK is running clock of Arm® Cortex® -M0+.
- (4) The frequency of AHB, APB2 (high-speed APB) and APB1 (low-speed APB) domains can be configured through multiple prescalers
- (5) When needing to run the peripheral connected to AHB and APB, it is required to turn on the corresponding enable end to make the peripheral get the clock signal.
- (6) Frequency assignment of all TMRxCLK (timer clocks) is automatically set by the hardware according to the following two situations:
 - If the corresponding APB prescaler factor is 1, the clock frequency of the timer is the same as that of the APB bus.
 - Otherwise, the clock frequency of the timer will be set to twice the frequency of the APB bus connected to it.

- (7) Moreover, the frequency of TMRx (x=1, 2, 3, 6, 7, 14, 15, 16, and 17) clock signal is divided through APB.
- (8) MCOCLK is connected to TMR14 not for providing clock signal for TMR14 but for clock measurement of TRM14.

5.3.5 Clock Source Selection of RTC

Select HSECLK/32, LSECLK or LSICLK as RTCCLK clock source by setting RCM_BDCTRL. The selection of clock source can be changed only when the backup domain is reset.

Because LSECLK is in the backup domain, and HSECLK and LSICLK are not in the backup domain, different RTCs will be selected as the clock source; the working condition of RTCs are different, and see the following table for details:

Table 19 Working Condition of RTC When RTC Selects Different Clock Sources

LSECLK is selected as RTC clock	As long as V _{BAT} maintains power supply, RTC will continue to work even if V _{DD} is powered off
LSICLK is selected as automatic wake-up unit (WAKEUP) unit	If V _{DD} is powered off, AWU state cannot be guaranteed.
HSECLK/32 as RTC clock	If the V _{DD} is powered off or the internal voltage regulator is turned off (the power supply of 1.5V domain is cut off), the RTC state is uncertain, so the DWPEN bit (cancel the write protection of backup area) of PMU_CTRL (power control register) must be set to "1".

5.3.6 Clock Source Selection of IWDT

When IWDT (independent watchdog) is opened, LSICLK oscillator will be opened by force, and when it is stable, the clock signal will be provided to IWDT. After LSICLK is opened by force, it will always be open and cannot be closed.

5.3.7 Clock Source Selection of MCO

When the corresponding GPIO port register is configured with corresponding function, the clock signal can be selected to be output to MCO pin by MCOSEL in configuration register RCM_CFG1 (clock configuration register). See the instructions for clock tree or MCOSEL bit of RCM_CFG1 register for specific clock signal.

5.3.8 Clock Source Selection of SYSCLK

SYSCLK clock source can be HSECLK, PLLCLK, HSICLK or HSICLK48.

The state bit of RCM_CFG1 can indicate the ready clock and selected SYSCLK clock source.

When the system is reset, HSICLK oscillator is selected as the system clock, and the clock source cannot be stopped when PLL is directly or indirectly used as the system clock. If you want to switch the SYSCLK clock source, you must wait until the destination clock source is ready (i.e. the destination clock source is stable).

5.3.9 CSS Clock Security System

In order to prevent MCU from normal operation due to external crystal oscillator short circuit, MCU can activate CSS clock security system through software. After the security system is activated, if the HSECLK oscillator is used as the system clock directly or indirectly (used as the PLL input clock and PLL is used as the system clock), the external HSECLK oscillator will be turned off when the HSECLK clock fails, and the system clock will automatically switch to HSICLK. At this time, the PLL which selects HSECLK as the clock input and as the system

clock input source will also be turned off.

CSS can be activated by software. When HSECLK clock fails, CSS interrupt will be generated, and NMI will be generated automatically. NMI will be executed continuously until the CSS interrupt pending bit is cleared. Therefore, CSSCLR bit in RCM_INT (clock interrupt register) must be set in NMI processing program to clear the CSS interrupt.

5.3.10 Clock Source Selection of ADC

The clock source of ADC is controlled through ADC_CFG2. It can select HSICLK14 or PCLK with the frequency divided by 2/4 as the clock source. When PCLK is used as the clock source of ADC, HSICLK14 cannot be changed over to ADC interface.

5.3.11 TMR14-based Internal/External Clock Measurement

Through the input capture function of TMR14 Channel 1, the frequency of all clock source generators on the motherboard can be indirectly measured. The circuit diagram is as follows:

Figure 5 TMR14 Indirect Measurement Clock Frequency Circuit Diagram

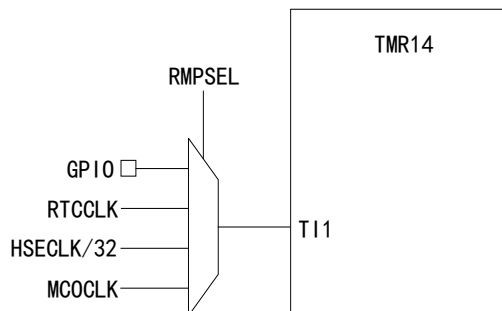

The input capture of TMR14 can select to connect the internal clock (RTCCLK, HSECLK/32, MCOCLK) of a GPIO port or a MCU by configuring RMPSEL bit of TMRx_OPT register of TMR14. See this register for specific configuration.

5.3.12 Low-power Mode

PCLK and DMACLK can be disabled by software.

Sleep mode:

- Stop CPU clock
- Flash and RAM interface clocks can be stopped by software
- When all peripheral clocks connected to APB bus are disabled, the hardware will stop the clocks of AHb1/APB bridge

Stop mode and standby mode:

- All 1.5V power domains are disabled
- PLLCLK, HSICLK, HSICLK14, HSICLK48 and HSECLK are disabled

Deep sleep mode:

- The system can be debugged by setting the STOP_CLK_STS bit and STANDBY_CLK_STS bit in DBGMCU_CFG.
- The system selects HSICLK as SYSCLK through interrupt (in stop mode) or reset (standby mode)
- If Flash programming is in progress, the system will enter deep sleep mode only after all programming operations are completed
- If APB domain is being used, the system will enter deep sleep mode only after all operations are completed

5.4 Register Address Mapping

Table 20 RCM Register Address Mapping

Register name	Description	Offset address
RCM_CTRL1	Clock control register 1	0x00
RCM_CFG1	Clock configuration register 1	0x04
RCM_INT	Clock interrupt register	0x08
RCM_APBRSST2	APB peripheral reset register 2	0x0C
RCM_APBRSST1	APB peripheral reset register 1	0x10
RCM_AHBCLKEN	AHB peripheral clock enable register	0x14
RCM_APBCLKEN2	APB peripheral clock enable register 2	0x18
RCM_APBCLKEN1	APB peripheral clock enable register 1	0x1C
RCM_BDCTRL	Backup domain control register	0x20
RCM_CSTS	Control/State register	0x24
RCM_AHBRST	AHB peripheral reset register	0x28
RCM_CFG2	Clock configuration register 2	0x2C
RCM_CFG3	Clock configuration register 3	0x30
RCM_CTRL2	Clock control register 2	0x34

5.5 Register Functional Description

5.5.1 Clock control register 1 (RCM_CTRL1)

Offset address: 0x00

Reset value: 0x0000 XX83; X means undefined

Access: Access in the form of word, half word and byte, without wait cycle

Field	Name	R/W	Description
0	HSIEN	R/W	High Speed Internal Clock Enable Set 1 or clear 0 by software. HSICLK is an RC oscillator. When one of the following conditions occurs, it will be set to 1 by the hardware: power-on start, software reset, wake-up from standby mode, wake-up from stop mode, failure of external high-speed clock source (as system clock or providing system clock through PLL). When HSICLK is used as system clock or provides system clock through PLL, this bit cannot be cleared. 0: HSICLK RC oscillator is disabled 1: HSICLK RC oscillator is enabled
1	HSIRDYFLG	R	High Speed Internal Clock Ready Flag 0: HSICLK RC oscillator is not stable 1: HSICLK RC oscillator is stable
2	Reserved		
7:3	HSITRM	R/W	High Speed Internal Clock Trim

Field	Name	R/W	Description
			The product has been calibrated to 8MHz±1% when leaving the factory. However, it changes as the temperature and voltage changes, but the frequency of HSICLK RC oscillator can be adjusted by HSITRM[4:0].
15:8	HSICAL	R	High Speed Internal Clock Calibrate It will be calibrated to 8MHz±1% before leaving the factory. When the system is started up, the calibration parameters will be automatically written to the register.
16	HSEEN	R/W	High Speed External Clock Enable When entering the standby or stop mode, this bit is cleared by hardware and HSECLK is turned off; when HSECLK is used as system clock source or the system clock is provided through PLL, this bit cannot be cleared. 0: HSECLK is disabled 1: HSECLK is enabled
17	HSERDYFLG	R	High Speed External Clock Ready Flag When HSECLK is stable, this bit is set to 1 by hardware and cleared by software. 0: HSECLK is not stable 1: HSECLK is stable
18	HSEBCFG	R/W	High Speed External Clock Bypass Configure Bypass mode refers to the mode in which external clock is used as the HSECLK clock source; otherwise the resonator is used as the HSECLK clock source. 0: Non-bypass mode 1: Bypass mode
19	CSSEN	R/W	Clock Security System Enable 0: Disable 1: Enable
23:20	Reserved		
24	PLLEN	R/W	PLL Enable When entering the standby and stop mode, this bit is cleared by the hardware; when PLLCLK has been configured (or in the process of configuration) as the clock source of the system clock, this bit cannot be cleared; in other cases, it can be set to 1 or cleared by the software. 0: PLL is disabled 1: PLL is enabled
25	PLLRDYFLG	R	PLL Clock Ready Flag PLL is set to 1 by hardware after it is locked. 0: PLL is unlocked 1: PLL is locked
31:26	Reserved		

5.5.2 Clock configuration register 1 (RCM_CFG1)

Offset address: 0x04

Reset value: 0x0000 0000

All bits of this register are set or cleared by software.

Access: Access in the form of word, half word and byte, with 0 to 2 wait cycles.

1 or 2 wait cycles are inserted only when the access occurs during clock switching.

Field	Name	R/W	Description
-------	------	-----	-------------

Field	Name	R/W	Description
1:0	SCLKSEL	R/W	System Clock Source Select When returning from stop or standby mode or the HSECLK directly or indirectly used as system clock fails, the hardware selects HSICLK as system clock by force (if the clock security system has been started) 00: HSICLK is used as system clock 01: HSECLK is used as system clock 10: PLLCLK is used as system clock 11: HSICLK48 is used as system clock (when HSICLK48 is enabled)
3:2	SCLKSELSTS	R	System Clock Selection Status Indicate which clock source is used as system clock; set to 1 or cleared by the hardware. 00: HSICLK is used as system clock 01: HSECLK is used as system clock 10: PLLCLK is used as system clock 11: HSICLK48 is used as system clock (when HSICLK48 is enabled)
7:4	AHBPSC	R/W	AHB Clock Prescaler Factor Configure Control the prescaler factor of AHB clock. 0xxx: No frequency division for SYSCLK 1000: SYSCLK 2-divided frequency 1001: SYSCLK 4-divided frequency 1010: SYSCLK 8-divided frequency 1011: SYSCLK 16-divided frequency 1100: SYSCLK 64-divided frequency 1101: SYSCLK 128-divided frequency 1110: SYSCLK 256-divided frequency 1111: SYSCLK 512-divided frequency Note: When the prescaler factor of AHB clock is greater than 1, the prefetch buffer must be enabled.
10:8	APB1PSC	R/W	APB1 Clock Prescaler Factor Configure Control the prescaler factor of low-speed APB1 clock (PCLK1) 0xx: No frequency division for HCLK 100: HCLK 2-divided frequency 101: HCLK 4-divided frequency 110: HCLK 8-divided frequency 111: HCLK 16-divided frequency
13:11	Reserved		
14	ADCPSC	R/W	ADCCLK Prescaler Factor Configure It is determined by the corresponding bit of ADC configuration register.
16:15	PLLSRCSEL	R/W	PLL Clock Source Select This bit can be changed only when PLL is closed. 00: HSICLK is used as PLL clock source after 2 frequency division 01: HSICLK is used as PLL clock source after frequency division 10: HSECLK is used as PLL clock source after frequency division 11: HSICLK48 used as PLL clock source after frequency division
17	PLLHSEPC	R/W	HSECLK Prescaler Factor for PLL Clock Source This bit refers to Bit 0 of RCM_CFG2.
21:18	PLLMULCFG	R/W	PLL Multiplication Factor Configure Determine PLL multiplication factor. This bit can be written only when PLL is closed. 0000: PLLCLK 2-multiple frequency output 0001: PLL 3-multiple frequency output 0010: PLL 4-multiple frequency output 0011: PLL 5-multiple frequency output 0100: PLL 6-multiple frequency output 0101: PLL 7-multiple frequency output 0110: PLL 8-multiple frequency output 0111: PLL 9-multiple frequency output 1000: PLL 10-multiple frequency output 1001: PLL 11-multiple frequency output 1010: PLL 12-multiple frequency output

Field	Name	R/W	Description
			1011: PLL 13-multiple frequency output 1100: PLL 14-multiple frequency output 1101: PLL 15-multiple frequency output 1110: PLL 16-multiple frequency output 1111: PLL 16-multiple frequency output Note: The output frequency of PLL cannot be greater than 48MHz.
23:22	Reserved		
27:24	MCOSEL	R/W	Main Clock Output Select Set or cleared by software. 0000: No clock output 0001: HSICLK14 is output as a clock 0010: LSICLK is output as a clock 0011: LSECLK is output as a clock 0100: SYCLK is output as a clock 0101: HSICLK is output as a clock 0110: HSECLK is output as a clock 0111: PLLCLK outputted as clock (the division factor is decided by MCOPLLSC) 1000: HSICLK48 outputted as clock
30:28	MCOPLSC	R/W	MCOCLK Prescaler Factor Configure This bit can be set only when MCOCLK is disabled. 000: MCOCLK1 divided frequency 001: MCOCLK 2 divided frequency 010: MCOCLK 4 divided frequency 011: MCOCLK 8 divided frequency 100: MCOCLK 16 divided frequency 101: MCOCLK 32 divided frequency 110: MCOCLK 64 divided frequency 111: MCOCLK 128 divided frequency
31	MCOPLLSC	R/W	PLLCLK Prescaler Factor for MCO Clock Source Configure Configure PLLCLK division factor which provides clock signal for MCO, and this bit can be changed only when MCOCLK is closed. 0: PLLCLK 2 divided frequency 1: No frequency division for PLLCLK

5.5.3 Clock interrupt register (RCM_INT)

Offset address: 0x08

Reset value: 0x0000 0000

Access: Access in the form of word, half word and byte, without wait cycle.

Field	Name	R/W	Description
0	LSIRDYFLG	R	LSICLK Ready Interrupt Flag When LSICLK is stable and LSIRDYEN bit is set to 1, this bit will be set to 1 by hardware; when LSIRDYCLR is set to 1 by software, this bit will be cleared. 0: No LSICLK ready interrupt 1: LSICLK ready interrupt occurred
1	LSERDYFLG	R	LSECLK Ready Interrupt Flag When LSECLK is stable and LSERDYEN bit is set to 1, this bit will be set to 1 by hardware; when LSERDYCLR is set to 1 by software, this bit will be cleared. 0: No LSECLK ready interrupt 1: LSECLK ready interrupt occurred

Field	Name	R/W	Description
2	HSIRDYFLG	R	<p>HSICLK Ready Interrupt Flag</p> <p>When HSICLK is stable and HSIRDYEN bit is set to 1, this bit will be set to 1 by hardware; when HSIRDYCLR is set to 1 by software, this bit will be cleared.</p> <p>0: No HSICLK ready interrupt 1: HSICLK ready interrupt occurred</p>
3	HSERDYFLG	R	<p>HSECLK Ready Interrupt Flag</p> <p>When HSECLK is stable and HSERDYEN bit is set to 1, this bit will be set to 1 by hardware; when HSERDYCLR is set to 1 by software, this bit will be cleared.</p> <p>0: No HSECLK ready interrupt 1: HSECLK ready interrupt occurred</p>
4	PLLRDYFLG	R	<p>PLL Ready Interrupt Flag</p> <p>When PLL is stable and PLLRDYEN bit is set to 1, this bit will be set to 1 by hardware; when PLLRDYCLR is set to 1 by software, this bit will be cleared.</p> <p>0: No clock ready interrupt caused by PLL locked 1: Clock ready interrupt caused by PLL locked</p>
5	HSI14RDYFLG	R	<p>HSICLK14 Ready Interrupt Flag</p> <p>When the internal high-speed clock is ready and the HSI14RDYEN bit is set to 1, it is set to 1 by hardware.</p> <p>When HSI14RDYCLR is set to 1 by software, this bit will be cleared.</p> <p>0: No security system interrupt caused by HSECLK failure 1: Security system interrupt is caused by HSECLK failure</p>
6	HSI48RDYFLG	R	<p>HSICLK48 Ready Interrupt Flag</p> <p>When the internal high-speed clock is ready and the HSI48RDYEN bit is set to 1, it is set to 1 by hardware.</p> <p>This bit is set to 1 by software and cleared by HSI48RDYCLR.</p> <p>0: No security system interrupt caused by HSECLK failure 1: Security system interrupt is caused by HSECLK failure</p>
7	CSSFLG	R	<p>Clock Security System Interrupt Flag</p> <p>When the external 4-16MHz oscillator clock fails, it is set to 1 by hardware.</p> <p>When CSSCLR is set to 1 by software, this bit will be cleared.</p> <p>0: No security system interrupt caused by HSECLK failure 1: Clock security system interrupt is caused by HSECLK failure</p>
8	LSIRDYEN	R/W	<p>LSICLK Ready Interrupt Enable</p> <p>Enable or disable internal 40kHz RC oscillator ready interrupt.</p> <p>0: Disable 1: Enable</p>
9	LSERDYEN	R/W	<p>LSECLK Ready Interrupt Enable</p> <p>Enable external 32kHz RC oscillator ready interrupt.</p> <p>0: Disable 1: Enable</p>
10	HSIRDYEN	R/W	<p>HSICLK Ready Interrupt Enable</p> <p>Enable the internal 8MHz RC oscillator ready interrupt.</p> <p>0: Disable 1: Enable</p>
11	HSERDYEN	R/W	<p>HSECLK Ready Interrupt Enable</p> <p>Enable external 4-16MHz oscillator ready interrupt.</p> <p>0: Disable 1: Enable</p>

Field	Name	R/W	Description
12	PLLRDYEN	R/W	PLL Ready Interrupt Enable Enable PLL ready interrupt. 0: Disable 1: Enable
13	HSI14RDYEN	R/W	HSICLK14 Ready Interrupt Enable Enable the internal 14MHz RC oscillator ready interrupt. 0: Disable 1: Enable
14	HSI48RDYEN	R/W	HSICLK48 Ready Interrupt Enable Enable the internal 48MHz RC oscillator ready interrupt. 0: Disable 1: Enable
15	Reserved		
16	LSIRDYCLR	W	LSICLK Ready Interrupt Clear Clear LSICLK ready interrupt flag bit LSIRDYFLG. 0: No effect 1: Clear
17	LSERDYCLR	W	LSECLK Ready Interrupt Clear Clear LSECLK ready interrupt flag bit LSERDYFLG. 0: No effect 1: Clear
18	HSIRDYCLR	W	HSICLK Ready Interrupt Clear Clear HSICLK ready interrupt flag bit HSIRDYFLG. 0: No effect 1: Clear
19	HSERDYCLR	W	HSECLK Ready Interrupt Clear Clear HSECLK ready interrupt flag bit HSERDYFLG. 0: No effect 1: Clear
20	PLLRDYCLR	W	PLL Ready Interrupt Clear Clear PLL ready interrupt flag bit PLLRDYFLG. 0: No effect 1: Clear
21	HSI14RDYCLR	W	HSICLK14 Ready Interrupt Clear Clear the ready interrupt flag bit HSI14RDYFLG of HSICLK14. 0: No effect 1: Clear
22	HSI48RDYCLR	W	HSICLK48 Ready Interrupt Clear Clear the ready interrupt flag bit HSI48RDYFLG of HSICLK48. 0: No effect 1: Clear
23	CSSCLR	W	Clock Security System Interrupt Clear Clear the security system interrupt flag bit CSSFLG. 0: No effect 1: Clear
31:24	Reserved		

5.5.4 APB peripheral reset register 2 (RCM_APBRST2)

Offset address: 0x0C

Reset value: 0x0000 0000

Access: Access in the form of word, half word and byte, without wait cycle.

All bits can be reset or cleared by software.

Field	Name	R/W	Description
0	SYSCFGRST	R/W	SYSCFG Reset 0: No effect 1: Reset
8:1	Reserved		
9	ADCRST	R/W	ADC Reset 0: No effect 1: Reset ADC
10	Reserved		
11	TMR1RST	R/W	TMR1 Timer Reset 0: No effect 1: Reset
12	SPI1RST	R/W	SPI1 Reset 0: No effect 1: Reset
13	Reserved		
14	USART1RST	R/W	USART1 Reset 0: No effect 1: Reset
15	Reserved		
16	TMR15RST	R/W	TMR15 Reset 0: No effect 1: Reset
17	TMR16RST	R/W	TMR16 Reset 0: No effect 1: Reset
18	TMR17RST	R/W	TMR17 Reset 0: No effect 1: Reset
21:19	Reserved		
22	DBGST	R/W	Debug Reset 0: No effect 1: Reset
31:23	Reserved		

5.5.5 APB peripheral reset register 1 (RCM_APBRST1)

Offset address: 0x10

Reset value: 0x0000 0000

Access: Access in the form of word, half word and byte, without wait cycle

Field	Name	R/W	Description
-------	------	-----	-------------

Field	Name	R/W	Description
0	TMR2RST	R/W	Timer 2 Reset 0: No effect 1: Reset
1	TMR3RST	R/W	Timer 3 Reset 0: No effect 1: Reset
3:2	Reserved		
4	TMR6RST	R/W	Timer 6 Reset 0: No effect 1: Reset
5	TMR7RST	R/W	Timer 7 Reset 0: No effect 1: Reset
7:6	Reserved		
8	TMR14RST	R/W	Timer 14 Reset 0: No effect 1: Reset
10:9	Reserved		
11	WWDTRST	R/W	Window Watchdog Reset 0: No effect 1: Reset
13:12	Reserved		
14	SPI2RST	R/W	SPI2 Reset 0: No effect 1: Reset
16:15	Reserved		
17	USART2RST	R/W	USART2 Reset 0: No effect 1: Reset
18	USART3RST	R/W	USART3 Reset 0: No effect 1: Reset
19	USART4RST	R/W	USART4 Reset 0: No effect 1: Reset
20	Reserved		
21	I2C1RST	R/W	I2C1 Reset 0: No effect 1: Reset
22	I2C2RST	R/W	I2C2 Reset 0: No effect 1: Reset

Field	Name	R/W	Description
23	USBD RST	R/W	USBD Reset 0: No effect 1: Reset
24	Reserved		
25	CAN RST	R/W	CAN Reset 0: No effect 1: Reset
26	Reserved		
27	CRS RST	R/W	CRS Reset 0: No effect 1: Reset
28	PMURST	R/W	Power Interface Reset 0: No effect 1: Reset
29	DAC RST	R/W	DAC Reset 0: No effect 1: Reset
30	CEC RST	R/W	HDMI-CEC Reset 0: No effect 1: Reset
31	Reserved		

5.5.6 AHB peripheral clock enable register (RCM_AHBCLKEN)

Offset address: 0x14

Reset value: 0x0000 0014

Access: Access in the form of word, half word and byte, without wait cycle.

All bits can be reset or cleared by software.

Note: When the peripheral clock is not enabled, the software cannot read the value of the peripheral register, and the value returned is always 0x0.

Field	Name	R/W	Description
0	DMA1EN	R/W	DMA1 Clock Enable 0: Disable 1: Enable
1	DMA2EN	R/W	DMA2 Clock Enable 0: Disable 1: Enable
2	SRAMEN	R/W	SRAM Interface Clock Enable Enable SRAM clock in sleep mode. 0: Disable 1: Enable
3	Reserved		
4	FMCEN	R/W	FMC Clock Enable Enable the flash interface circuit clock in sleep mode. 0: Disable 1: Enable

Field	Name	R/W	Description
5	Reserved		
6	CRCEN	R/W	CRC Clock Enable 0: Disable 1: Enable
16:7	Reserved		
17	PAEN	R/W	I/O PortA Clock Enable 0: Disable 1: Enable
18	PBEN	R/W	I/O PortB Clock Enable 0: Disable 1: Enable
19	PCEN	R/W	I/O PortC Clock Enable 0: Disable 1: Enable
20	PDEN	R/W	I/O PortD Clock Enable 0: Disable 1: Enable
21	PEEN	R/W	I/O PortE Clock Enable 0: Disable 1: Enable
22	PFEN	R/W	I/O PortF Clock Enable 0: Disable 1: Enable
23	Reserved		
24	TSCEN	R/W	TSC Clock Enable 0: Disable 1: Enable
31:25	Reserved		

5.5.7 APB peripheral clock enable register 2 (RCM_APBCLKEN2)

Offset address: 0x18

Reset value: 0x0000 0000

Access: Access in the form of word, half word and byte

Usually there is no wait cycle. However, when the peripheral on the APB2 bus is accessed, the waiting state will be inserted until the APB2 peripheral access ends.

All bits can be reset or cleared by software.

Note: When the peripheral clock is not enabled, the software cannot read the value of the peripheral register, and the value returned is always 0x0.

Field	Name	R/W	Description
0	SCFGCOMPEN	R/W	SYSCFG Clock And COMP Clock Enable 0: Disable 1: Enable
8:1	Reserved		
9	ADCEN	R/W	ADC Interface Clock Enable 0: Disable 1: Enable

Field	Name	R/W	Description
10	Reserved		
11	TMR1EN	R/W	TMR1 Timer Clock Enable 0: Disable 1: Enable
12	SPI1EN	R/W	SPI 1 Clock Enable 0: Disable 1: Enable
13	Reserved		
14	USART1EN	R/W	USART1 Clock Enable 0: Disable 1: Enable
15	Reserved		
16	TMR15EN	R/W	TMR15 Timer Clock Enable 0: Disable 1: Enable
17	TMR16EN	R/W	TMR16 Timer Clock Enable 0: Disable 1: Enable
18	TMR17EN	R/W	TMR17 Timer Clock Enable 0: Disable 1: Enable
21:19	Reserved		
22	DBGEN	R/W	Debug Clock Enable 0: Disable 1: Enable
31:23	Reserved		

5.5.8 APB peripheral clock enable register 1 (RCM_APBCLKEN1)

Offset address: 0x1C

Reset value: 0x0000 0000

Access: Access in the form of word, half word and byte

Usually there is no wait cycle. However, when the peripheral on the APB bus is accessed, the waiting state will be inserted until the APB peripheral access ends.

All bits can be reset or cleared by software.

Note: When the peripheral clock is not enabled, the software cannot read the value of the peripheral register, and the value returned is always 0x0.

Field	Name	R/W	Description
0	TMR2EN	R/W	Timer 2 Clock Enable 0: Disable 1: Enable
1	TMR3EN	R/W	Timer 3 Clock Enable 0: Disable 1: Enable
3:2	Reserved		

Field	Name	R/W	Description
4	TMR6EN	R/W	Timer 6 Clock Enable 0: Disable 1: Enable
5	TMR7EN	R/W	Timer 7 Clock Enable 0: Disable 1: Enable
7:6	Reserved		
8	TMR14EN	R/W	Timer 14 Clock Enable 0: Disable 1: Enable
10:9	Reserved		
11	WWDTEN	R/W	Window Watchdog Clock Enable 0: Disable 1: Enable
13:12	Reserved		
14	SPI2EN	R/W	SPI 2 Clock Enable 0: Disable 1: Enable
16:15	Reserved		
17	USART2EN	R/W	USART 2 Clock Enable 0: Disable 1: Enable
18	USART3EN	R/W	USART 3 Clock Enable 0: Disable 1: Enable
19	USART4EN	R/W	USART 4 Clock Enable 0: Disable 1: Enable
20	Reserved		
21	I2C1EN	R/W	I2C1 Clock Enable 0: Disable 1: Enable
22	I2C2EN	R/W	I2C2 Clock Enable 0: Disable 1: Enable
23	USBDEN	R/W	USB Clock Enable 0: Disable 1: Enable
24	Reserved		
25	CANEN	R/W	CAN Clock Enable 0: Disable 1: Enable
26	Reserved		

Field	Name	R/W	Description
27	CRSEN	R/W	CRS Clock Enable 0: Disable 1: Enable
28	PMUEN	R/W	Power Interface Clock Enable 0: Disable 1: Enable
29	DACEN	R/W	DAC Clock Enable 0: Disable 1: Enable
30	CECEN	R/W	HDMI-CEC Clock Enable 0: Disable 1: Enable
31	Reserved		

5.5.9 Backup domain control register (RCM_BDCTRL)

Offset address: 0x20

Reset value: 0x0000 0018, which can be reset effectively only by backup domain

Access: Access in the form of word, half word and byte, with 0 to 3 wait cycles

When the register is accessed continuously, the waiting state will be inserted.

Note: Only when BPWEN bit in PMU_CTRL is set to 1, can LSEEN, LSEBCFG, RTCSRCSEL and RTCCLKEN be changed.

Field	Name	R/W	Description
0	LSEEN	R/W	Low-Speed External Oscillator Enable 0: Disable 1: Enable
1	LSERDYFLG	R	Low-Speed External Clock Ready Flag When LSECLK is stable, this bit is set to 1 by hardware, and when it is unstable, it is cleared by hardware. 0: Not ready 1: Ready
2	LSEBCFG	R/W	Low-Speed External Clock Bypass Mode Configure Bypass mode refers to the mode in which external clock is used as the LSECLK clock source; otherwise the resonator is used as the LSECLK clock source. 0: Non-bypass mode 1: Bypass mode
4:3	LSEDRVCFG	R/W	LSE Oscillator Drive Capability Configure This bit is set or cleared by software; set the driving capability of LSECLK oscillator (crystal mode is not bypassed). When the backup domain is reset, this bit is restored to the default value. 00: Weak 01: Medium and high 10: Medium and low 11: Strong
7:5	Reserved		

Field	Name	R/W	Description
9:8	RTCSRCSEL	R/W	RTC Clock Source Select First set the RTCRST bit to reset the backup domain, and then select the RTC clock source. It is impossible to directly configure the register to modify. 00: No clock 01: LSECLK is used as RTC clock 10: LSICLK is used as RTC clock 11: HSECLK is used as RTC clock after 32 divided frequency
14:10	Reserved		
15	RTCCLKEN	R/W	RTC Clock Enable 0: Disable 1: Enable
16	BDRST	R/W	Backup Domain Software Reset Set 1 or clear 0 by software 0: Reset is not activated 1: Reset the backup domain (only affect LSECLK oscillator, RTC real-time clock and register RCM_BDCTRL)
31:17	Reserved		

5.5.10 Control/State register (RCM_CSTS)

Offset address: 0x24

Reset value: 0xXXX0 0000, except reset flag, all are cleared by system reset, and reset flag can only be cleared by power reset.

Access: Access in the form of word, half word and byte, with 0 to 3 wait cycles.

When the register is accessed continuously, the waiting state will be inserted.

Field	Name	R/W	Description
0	LSIEN	R/W	Low-Speed Internal Oscillator Enable Set 1 or clear 0 by software. 0: Disable 1: Enable
1	LSIRDYFLG	R	Low-Speed Internal Oscillator Ready Flag When LSICLK is stable, this bit is set to 1 by hardware, and when it is unstable, it is cleared by hardware. 0: Not ready 1. Ready
22:2	Reserved		
23	PWRRSTFLG	R	Reset Flag of The 1.5V Domain Set by hardware when a POR/PDR of the 1.5V domain occurred and cleared by setting RSTFLGCLR.
24	RSTFLGCLR	RT_W	Reset Flag Clear The reset flag is set or cleared by software, including RSTFLGCLR. 0: No effect 1: Clear the reset flag
25	OBRSTFLG	R	Option Byte Loader Reset Flag When the option byte load reset occurs, it is set by hardware; otherwise, it is set and cleared by RSTFLGCLR. 0: Reset does did not occur 1: Reset occurred

Field	Name	R/W	Description
26	PINRSTFLG	R	PIN Reset Flag It is set by hardware when pin reset occurs; otherwise it is cleared by setting RSTFLGCLR. 0: Reset does did not occur 1: Reset occurred
27	PODRSTFLG	R	POR/PDR Reset Occur Flag Set to 1 by hardware; cleared by software by writing RSTFLGCLR bit. 0: No power-on/power-down reset occurs 1: Power-on/power-down reset occurs
28	SWRSTFLG	R	Software Reset Occur Flag Set to 1 by hardware; cleared by software by writing RSTFLGCLR bit. 0: Not occur 1: Occurred
29	IWDTRSTFLG	R	Independent Watchdog Reset Occur Flag When independent watchdog reset occurs in VDD area, it is set to 1 by hardware and cleared by software by writing RSTFLGCLR bit. 0: Not occur 1: Occurred
30	WWDTRSTFLG	R	Window Watchdog Reset Occur Flag When window watchdog is reset, it is set to 1 by hardware and cleared by software by writing RSTFLGCLR bit. 0: Not occur 1: Occurred
31	LPWRRSTFLG	R	Low Power Reset Occur Flag When low-power management is reset, it is set to 1 by hardware and cleared by software by writing RSTFLGCLR bit. 0: Not occur 1: Occurred

5.5.11 AHB peripheral reset register (RCM_AHBRST)

Offset address: 0x28

Reset value: 0x0000 0000

Access: Access in the form of word, half word and byte, without wait cycle

Set 1 or clear 0 by software.

Field	Name	R/W	Description
16:0	Reserved		
17	PARST	R/W	I/O Port A Reset 0: Invalid 1: Reset
18	PBRST	R/W	I/O Port B Reset 0: Invalid 1: Reset

Field	Name	R/W	Description
19	PCRST	R/W	I/O Port C Reset 0: Invalid 1: Reset
20	PDRST	R/W	I/O Port D Reset 0: Invalid 1: Reset
21	PERST	R/W	I/O Port E Reset 0: Invalid 1: Reset
22	PFRST	R/W	I/O Port F Reset 0: Invalid 1: Reset
23	Reserved		
24	TSCRST	R/W	TSC Reset 0: Invalid 1: Reset
31:25	Reserved		

5.5.12 Clock configuration register 2 (RCM_CFG2)

Offset address: 0x2C

Reset value: 0x0000 0000

Access: Access in the form of word, half word and byte, without wait cycle

Field	Name	R/W	Description
3:0	PLLDIVCFG	R/W	PLLCLK Input Division Factor Configure Configure the input clock signal division factor of PLLCLK. 0000: No frequency of division 0001: 2 divided frequency 0010: 3 divided frequency 1111: 16 divided frequency
31:4	Reserved		

5.5.13 Clock configuration register 3 (RCM_CFG3)

Offset address: 0x30

Reset value: 0x0000 0000

Access: Access in the form of word, half word and byte, without wait cycle

Field	Name	R/W	Description
1:0	USART1SEL	R/W	USART1 Clock Source Select Set or cleared by software. The default value is 00. 00: PCLK is used as USART1CLK 01: SYSCLK is used as USART1CLK 10: LSECLK is used as USART1CLK 11: HSICLK is used as USART1CLK

Field	Name	R/W	Description
3:2	Reserved		
4	I2C1SEL	R/W	I2C1 Clock Source Select Set or cleared by software. The default value is 0. 0: HSICLK is used as I2C1CLK 1: SYSCLK is used as I2C1CLK
5	Reserved		
6	CECSEL	R/W	HDMI-CEC Clock Source Select Set or cleared by software. The default value is 0. 0: HSICLK is used as CECCLK after 244 frequency division 1: PLLCLK is used as CECCLK
7	USBDSSEL	R/W	USB D Clock Source Select Set or cleared by software. The default value is 0. 0: HSICLK48 is used as USB DCLK 1: PLLCLK is used as USB DCLK
8	ADCSEL	R/W	ADC Clock Source Select Maintain the reset value, HSICLK14 is used as asynchronous clock input of ADCCLK, and the clock source of ADCCLK is determined by ADC_CFG2.
15:9	Reserved		
17:16	USART2SEL	R/W	USART2 Clock Source Select Set or cleared by software. The default value is 00. 00: PCLK is used as USART2CLK 01: SYSCLK is used as USART2CLK 10: LSECLK is used as USART2CLK 11: HSICLK is used as USART2CLK
31:18	Reserved		

5.5.14 Clock control register 2 (RCM_CTRL2)

Offset address: 0x34

Reset value: 0xXX00 XX80; X means undefined

Access: Access in the form of word, half word and byte, without wait cycle

Field	Name	R/W	Description
0	HSI14EN	R/W	HSICLK14 Enable Set 1 or clear 0 by software. 0: Internal 14MHz oscillator OFF 1: Internal 14MHz oscillator ON
1	HSI14RDFLG	R	HSICLK14 Ready Flag This bit is set by hardware to indicate the state of HSICLK14 oscillator. 0: Not ready 1: Ready
2	HSI14TO	R/W	ADC Interface Turn On HSICLK14 ADC interface can turn on HSICLK14 oscillator, which is set or cleared by hardware. 0: Can be turned on 1: Cannot be turned on

Field	Name	R/W	Description
7:3	HSI14TRM	R/W	HSICLK14 Trim The product has been calibrated to 14MHz±1% when leaving the factory. However, it changes as the temperature and voltage changes, but the frequency of HSICLK14 RC oscillator can be adjusted by HSI14TRM.
15:8	HSI14CAL	R	HSICLK14 Calibrate It will be calibrated to 14MHz±1% before leaving the factory. When the system is started up, the calibration parameters will be automatically written to the register.
16	HSI48EN	R/W	HSICLK48 Enable Set 1 or clear 0 by software. 0: Internal 48MHz oscillator OFF 1: Internal 48MHz oscillator ON
17	HSI48RDFLG	R	HSICLK48 Ready Flag This bit is set by hardware to indicate the state of HSICLK48 oscillator. 0: Not ready 1: Ready
23:18	Reserved		
31:24	HSI48CAL	R	HSICLK48 Calibrate When the system is started, the calibration parameters will be automatically written to the register.

6 Clock Recovery System (CRS)

6.1 Full Name and Abbreviation Description of Terms

Table 21 Full Name and Abbreviation Description of Terms

Full name in English	English abbreviation
Clock Recovery System	CRS
Start of Frame	SOF
Synchronization	SYNC
Expected Synchronization	ESYNC
Synchronization in Normal	SYNCFORM
Synchronization Warning	SYNCFWARN
Synchronization or Trimming Error	ERROR
Synchronization Miss	SYNCFMISS
Tolerance Limit	LMT
Warning Limit	WLMT
Outrance Limit	OLMT
Frequency Error	FE

6.2 Introduction

CRS is an advanced digital controller used to automatically adjust the frequency of HSICLK48 RC oscillator. It contains a frequency error counter (16-bit) used to capture automatic error and overload. It evaluates the output frequency through the optional synchronization signal, and adjusts the oscillator automatically or manually according to the frequency error. The manual adjustment can speed up the start-up fusion.

6.3 Main Characteristics

(1) Programmable prescaler and polarity optional synchronous source:

- External pin CRS_SYNC
- LSECLK oscillator output pin
- USBDF SOF data receiving signal

(2) Maskable interrupt events:

- ESYNC
- SYNCFNORM
- SYNCFWARN
- ERROR

- (3) Synchronous pulse can be 59chmitt5959 by softwawre
- (4) Automatic adjustment of the oscillator can be realized, not needing CPU operation
- (5) Used for automatic frequency error comparison and state report programmable limit
- (6) In sleep state, CRS can still work normally

6.4 Functional Description

6.4.1 Synchronous Input

Select synchronous input source by configuring CRS_CFG, select the signal source polarity and division factor, or generate synchronous event by setting SWSGMR bit of CRS_CTRL.

6.4.2 Frequency Error Count

The frequency error counter is a counter which can increase or decrease. Every time an SYNC event occurs, the 16-bit RLDVAL value will be reloaded. At this time, the counter will count down to zero and generate an ESYNC event, and then count up. If the SYNC event is still not received when the count reaches OLMT (128 times of the limit value), an SYNMISS event will be generated.

If an SYNC event is detected when the counter is counting down, it means that the actual frequency is less than the target frequency; If an SYNC event is detected when the counter is counting up, it means that the actual frequency is greater than the target frequency.

6.4.3 Frequency Error Comparison and Automatic Fine Tuning

In FE comparison, three kinds of limits can be used as evaluation standard:

- LMT=limit value, given by FELMT of CRS_CFG
- WLMT=3*LMT
- OLMT=128*LMT

These limits are used to generate results after comparing with the frequency error, so as to control the adjustment operation. The following table shows the relationship of automatic fine adjustment when different results are obtained.

Table 22 FE Comparison Results and Fine Tuning Operation

Comparison result	Indication status	Meanings of results	Fine tuning operation
FELMT	SYNCFORM	TRM value is optimal solution	No fine tuning operation
$LMT \leq FE < WLMT$	SYNCFORM	TRM value can be optimized to optimum solution only through one step	One-step fine tuning operation

Comparison result	Indication status	Meanings of results	Fine tuning operation
WLMT \leq FE < OLMT	SYNCWARN	TRM value can be optimized to optimum solution through complex steps	Several-step fine tuning operation
OLMT \leq FE	ERROR or SYNCMISS	TRM value cannot be optimized to optimum solution through fine tuning	No fine tuning operation

6.5 Register Address Mapping

Table 23 CRS Register Address Mapping

Register name	Description	Offset address
CRS_CTRL	CRS control register	0x00
CRS_CFG	CRS configuration register	0x04
CRS_INTSTS	CRS interrupt and state register	0x08
CRS_INTCLR	CRS interrupt flag clear register	0x0C

6.6 Register Functional Description

6.6.1 CRS control register (CRS_CTRL)

Offset address: 0x00

Reset value: 0x0000 2000

Field	Name	R/W	Description
0	SNINTEN	R/W	SYNCSYNC Event Interrupt Enable 0: Disable 1: Enable
1	SWINTEN	R/W	SYNCWARN Event Interrupt Enable 0: Disable 1: Enable
2	EINTEN	R/W	ERROR Event Interrupt Enable 0: Disable 1: Enable
3	ESINTEN	R/W	ESYNC Event Interrupt Enable 0: Disable 1: Enable
4	Reserved		
5	CNTEN	R/W	Frequency Error Counter Enable 0: Disable 1: Enable

Field	Name	R/W	Description
6	AUTOTRMEN	R/W	Automatic Trimming Operation Enable 0: Disable 1: Enable
7	SWSGNR	R/W	Software SYNC Event Generate 0: No operation 1: Generate events
13:8	HSI48TRM	R/W	Frequency of HSI48 Oscillator Smooth Trim
31:14	Reserved		

6.6.2 CRS configuration register (CRS_CFG)

Offset address: 0x04

Reset value: 0x2022 BB7F

This register can be rewritten only after the frequency error counter is disabled; otherwise, write protection operation will be performed.

Field	Name	R/W	Description
15:0	RLDVAL	R/W	Frequency Error Counter Reload Value This value will be reloaded to the frequency error counter every time SYNC event occurs.
23:16	FELMT	R/W	Frequency Error Limit This value includes the value of frequency error that has been captured.
26:24	SYNCPSC	R/W	SYN Prescaler Division factor for controlling the synchronous signal. 000: No frequency division 001: 2 divided frequency 010: 4 divided frequency 011: 8 divided frequency 100: 16 divided frequency 101: 32 divided frequency 110: 64 divided frequency 111: 128 divided frequency
27	Reserved		
29:28	SYNCSRCSEL	R/W	SYNC Source Select Select the signal source of synchronous signal. 00: GPIO is used as signal source 01: LSECLK is used as signal source 10: USB D+ SOF is used as signal source 11: Reserved Note: After waking up from the sleep mode, selecting USB D+ SOF as the signal source cannot ensure the precision of the clock.

Field	Name	R/W	Description
30	Reserved		
31	SYNCPOLSEL	R/W	SYNC Source Input Polarity Select 0: Rising edge is effective (default) 1: Falling edge is effective

6.6.3 CRS interrupt and state register (CRS_INTSTS)

Offset address: 0x08

Reset value: 0x0000 0000

Field	Name	R/W	Description
0	SNFLG	R	SYNCSNORM Event Flag When the frequency error is less than three times of the limit, the synchronous signal is normal. 0: Abnormal synchronization 1: Normal synchronization
1	SWFLG	R	SYNCSWARM Event Flag When the frequency error is not less than three times of the limit value and is less than 128 times of the limit value, an SYNCSWARM event will occur. 0: SYNCSWARM did not occur 1: SYNCSWARM occurred
2	EFLG	R	ERROR Event Flag This bit is set to 1 by hardware and cleared by software.
3	ESFLG	R	ESYNC Event Flag When the frequency error reaches 0, an ESYNC event will occur. 0: ESYNC event did not occur 1: ESYNC event occurred
7:4	Reserved		
8	ERRORFLG	R	SYNC Error Flag When the frequency error is greater than 128 times of the limit value, it means that the error is too large, and the signal can not be synchronized by adjusting the TRIM value. 0: No error occurred 1: An error occurred
9	SYNCSMISS	R	SYNC Miss Flag When the frequency error is greater than 128 times of the limit value and no SYNC is detected, it means SYNC is lost. 0: SYNC is not lost 1: SYNC is lost

Field	Name	R/W	Description
10	TRMFLG	R	Trimming Overflow or Underflow Flag When automatic trimming causes overrun or underrun of TRIM value, a signal will be transmitted. 0: Overrun or underrun did not occur 1: Overrun or underrun occurred
14:11	Reserved		
15	CNTDRCT	R	Frequency Error Counter Direction It indicates the count direction of frequency error counter when the last SYNC event occurs. If it is incremental, it means the actual frequency is higher than the target frequency; otherwise, the actual frequency is lower than the target frequency. 0: Increase 1: Decrease
31:16	FECPT	R	Frequency Error Capture Record the value of frequency error counter when the last SYNC event occurs.

6.6.4 CRS interrupt flag clear register (CRS_INTCLR)

Offset address: 0x0C

Reset value: 0x0000 0000

Field	Name	R/W	Description
0	SNCLR	R/W	SYNCFORM Event Flag Clear 0: Invalid 1: Clear
1	SWCLR	R/W	SYNCWARM Event Flag Clear 0: Invalid 1: Clear
2	ECLR	R/W	ERROR Event Flag Clear 0: Invalid 1: Clear
3	ESCLR	R/W	ESYNC Event Flag Clear 0: Invalid 1: Clear
31:4	Reserved		

7 Power Management Unit (PMU)

7.1 Full Name and Abbreviation Description of Terms

Table 24 Full Name and Abbreviation Description of Terms

Full name in English	English abbreviation
Power Management Unit	PMU
Power On Reset	POR
Power Down Reset	PDR
Power Voltage Detector	PVD

7.2 Introduction

The power supply is the basis for stable operation of a system. The working voltage is 2.0~3.6V. It can provide 1.5V power supply through the built-in voltage regulator. If the main power V_{DD} is powered down, it can supply power to the backup power supply area through V_{BAT} .

7.3 Structure Block Diagram

Figure 6 Power Supply Control Structure Block Diagram

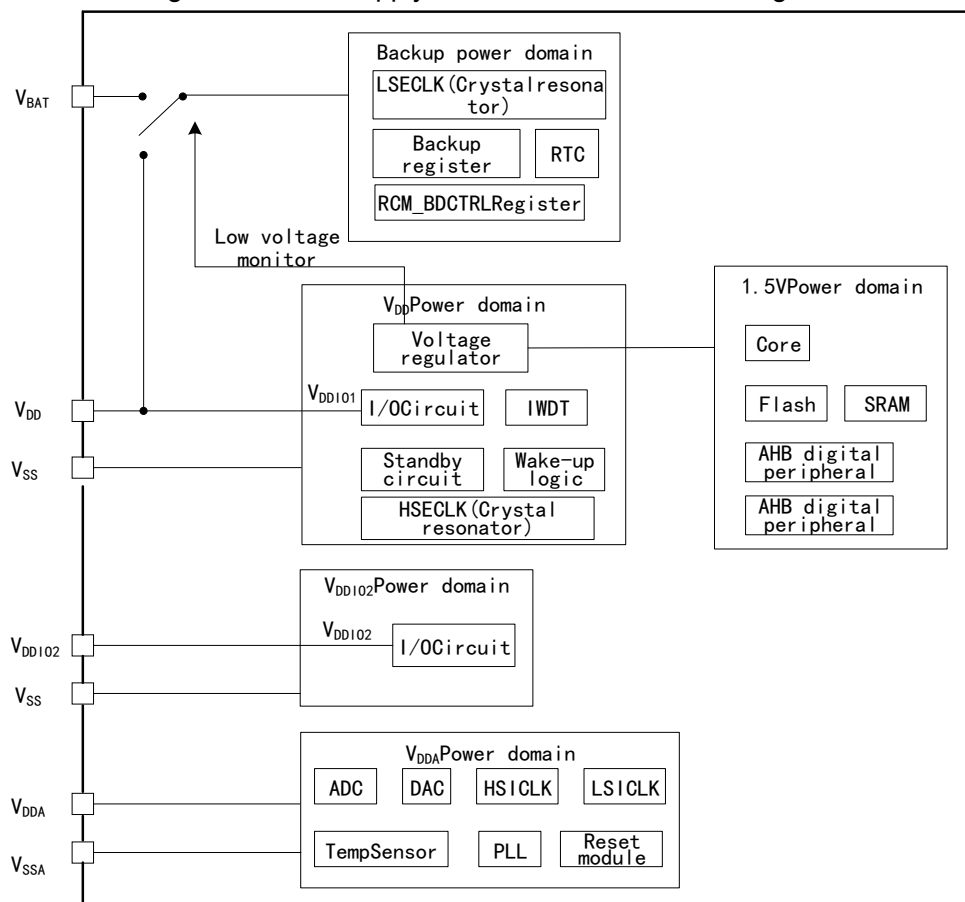

7.4 Functional Description

7.4.1 Power Domain

The power domain of the product includes: V_{DD} power domain, V_{DDA} power domain, 1.5V power domain, backup power domain and V_{DDIO2} power domain.

7.4.1.1 V_{DD} power domain

Power supply is provided through V_{DD}/V_{SS} pins to power the voltage regulator, standby circuit, IWDT, HSECLK, I/O (except PC13, PC14, PC15 pins) and wake-up logic.

Voltage regulator

Power can be supplied to 1.5V power domain in the following operating modes:

- Normal mode: In this mode, 1.5V power supply area runs at full power
- Stop mode: In this mode, 1.5V power supply area works in low power state, all clocks are off, and peripherals stop work
- Standby mode: In this mode, the 1.5V power supply area stops power supply, and except for the standby circuit, the content of register and SRAM will be lost

7.4.1.2 V_{DDA} power domain

Power the ADC, DAC, HSICLK, LSICLK, PLL and reset module through V_{DDA}/V_{SSA} pins.

Independent ADC power supply

Independent ADC power supply can improve conversion accuracy, and the specific power pins are as follows:

- V_{DDA} : Power pin of ADC
- V_{SSA} : Independent power ground pin

7.4.1.3 1.5V power domain

The core, Flash, SRAM and digital peripherals are powered by voltage regulator.

7.4.1.4 Backup power domain

When V_{DD} exists, the backup power supply area is powered by V_{DD} . When V_{DD} is powered down, the backup power supply area is powered by V_{BAT} , which is used to save the content of backup register and maintain RTC function. Power the LSECLK crystal oscillator, RTC, backup register and RCM_BDCTRL register, PC13, PC14 and PC15.

7.4.1.5 V_{DDIO2} power supply domain

Supply power through V_{DDIO2} pin and the power supply range is 1.65V~3.6V.

V_{DDIO2} voltage is completely independent of V_{DD} or V_{DDA} , and when V_{DD} is powered down, V_{DDIO2} will supply power.

7.4.2 Power Management

7.4.2.1 Power-on/power-down reset (POR and PDR)

When the V_{DD}/V_{DDA} is detected to be lower than the threshold voltage V_{POR} and V_{PDR} , the chip will automatically maintain the reset state. The waveform diagrams of power-on reset and power-down reset are as follows. For POR, PDR, hysteresis voltage and hysteresis time, please refer to the “Datasheet”.

Figure 7 Power-on Reset and Power-down Reset Oscillogram

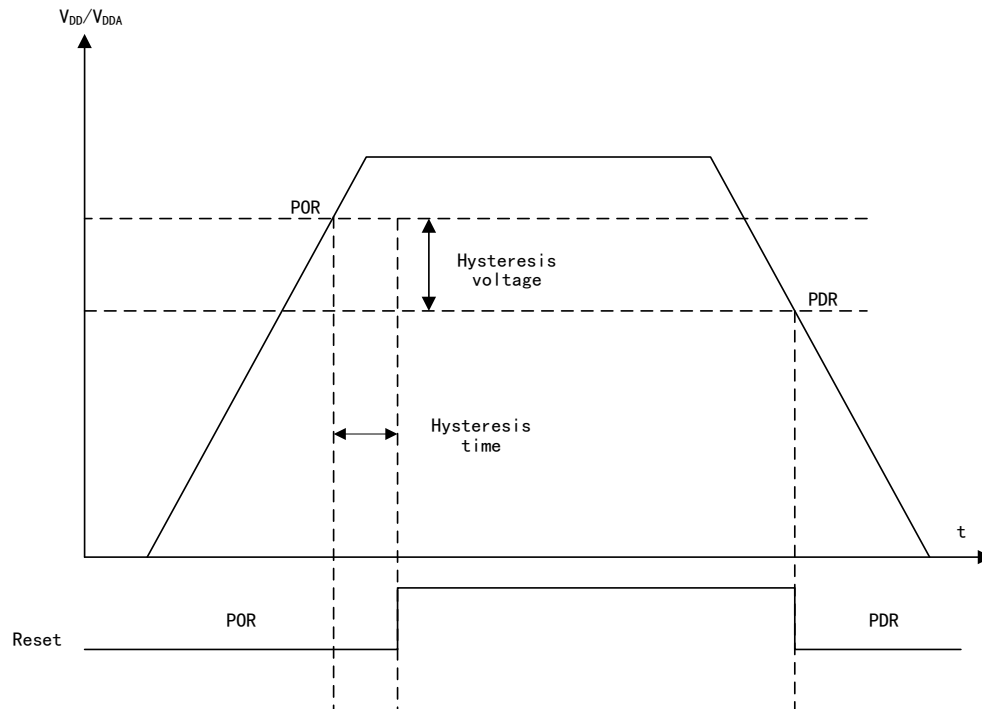

7.4.2.2 Programmable voltage detector (PVD)

A threshold can be set for PVD to monitor whether V_{DD}/V_{DDA} is higher or lower than the threshold. If interrupt is enabled, the interrupt can be triggered to process V_{DD}/V_{DDA} exceeding the threshold in advance. The usage of PVD is as follows:

- (1) Set the PVDEN bit of the configuration register PMU_CTRL to 1 to enable PVD
- (2) Select the voltage threshold of PVD for the PLSEL[2:0] bit of the configuration register PMU_CTRL
- (3) The PVDOFLG bit of the configuration register PMU_CSTS indicates the value of V_{DD} is higher or lower than the threshold of PVD
- (4) When it is detected that V_{DD}/V_{DDA} is lower or higher than the threshold of PVD, PVD interrupt will be generated

The threshold waveform of PVD is shown below. Please see “Datasheet” for PVD threshold and hysteresis voltage.

Figure 8 PVD Threshold Oscillogram

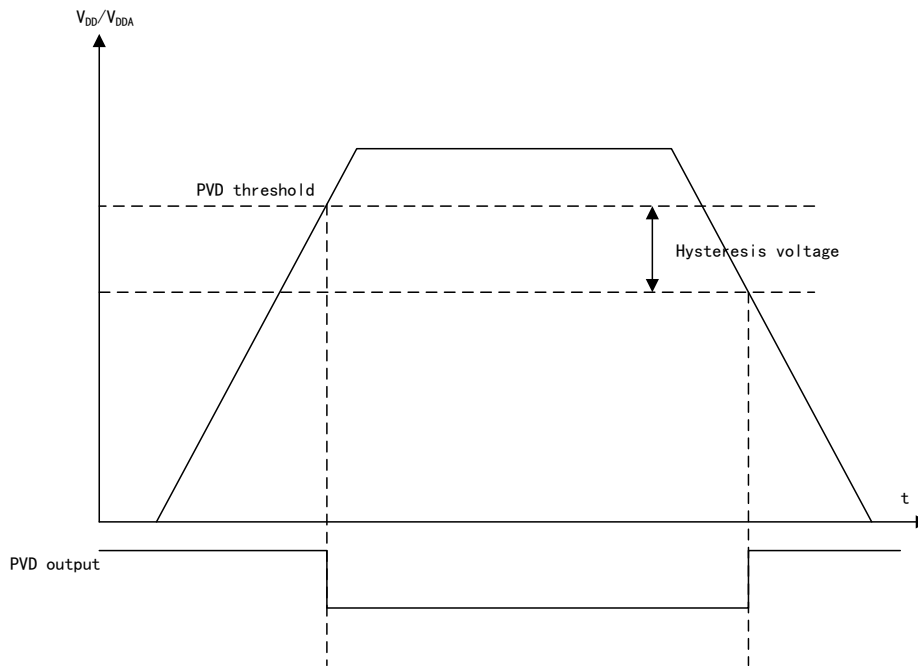

7.4.3 Power Consumption Control

7.4.3.1 Reduce the power consumption in low-power mode

There are three low-power modes: sleep mode, stop mode and standby mode. The power consumption is reduced by closing the core and clock source and setting the voltage regulator.

The power consumption, wake-up start time, wake-up mode and data storage of each low-power mode are different; the lower the power consumption is, the longer the wake-up time is, the less the wake-up mode is, the less the data saved are after wake-up; users can choose the most appropriate low-power mode according to their needs. The following table shows the difference among three low-power modes.

Table 25 Difference among “Sleep Mode, Stop Mode and Standby Mode”

Mode	Instruction	Entry mode	Wake-up mode	Voltage regulator	Effect on 1.5V area clock	Effect on V _{DD} area clock
Sleep	Arm® Cortex®-M0+ core stops, and all peripherals including the core peripheral are still working	Call WFI instruction	Any interrupt	Open	Only the core clock is turned off and it has no effect on other clocks and ADC clocks	None
		Call WFE instruction	Wake-up event			None

Mode	Instruction	Entry mode	Wake-up mode	Voltage regulator	Effect on 1.5V area clock	Effect on V _{DD} area clock
Stop	All clocks have stopped	PDDSCFG and LPDSCFG bits +SLEEPDEEP bit +WFI or WFE	Any external interrupt	Turn on or be in low-power mode	Close clocks of all 1.5V areas	The oscillator of HSICLK and HSECLK is turned off
Standby	1.5V power off	PDDSCFG bit +SLEEPDEEP bit +WFI or WFE	Rising edge of WKUP pin, RTC alarm event, external reset on NRST pin, IWDG reset	Off		

Sleep mode

The characteristics of sleep mode are shown in the table below

Table 26 Characteristics of Sleep Mode

Characteristics	Instruction
Enter	Enter the sleep mode immediately by executing WFI or WFE instructions; When SLEEPONEINT is set to 0 and WFI or WFE instruction is executed, the system will enter the sleep mode immediately; when SLEEPONEINT is set to 1, the system will exit the interrupt program and then enter the sleep mode immediately.
Wake-up	If WFI instruction is executed to enter the sleep mode, wake up by any interrupt; If WFE instruction is executed to enter the sleep mode, wake up through an event.
Sleep	The core stops working, all peripherals are still running, and the data in the core registers and memory before sleep are saved.
Wake-up delay	None
After wake-up	If the system is woken up by interrupt, it will first enter the interrupt, then exit the interrupt, and then execute the program after WFI instruction. If the system is woken up by event, it will directly execute the program after WFE instruction.

Stop mode

The characteristics of stop mode are shown in the table below:

Table 27 Characteristics of Stop Mode

Characteristics	Instruction
Enter	SLEEPDEEP bit of the core register is set to 1, PDDSCFG bit of the register PMU_CTRL is set to 0, and when executing WFI or WFE instruction, the system will enter the stop mode immediately; When LPDSCFG bit of the register PMU_CTRL is set to 0, the voltage regulator is working in normal mode; when LPDSCFG bit of the register PMU_CTRL is set to 1, the voltage regulator is working in low-power mode.
Wake-up	If WFI instruction is executed to enter the sleep mode, wake up by any interrupt; If WFE instruction is executed to enter the sleep mode, wake up through an event.
Stop	The core will stop working, the peripheral will stop working, and the data in the core register and memory before stop will be saved.
Wake-up delay	HSICLK oscillator wake-up time + voltage regulator wake-up time from low-power mode.
After wake-up	If the system is woken up by interrupt, it will first enter the interrupt, then exit the interrupt, and then execute the program after WFI instruction. If the system is woken up by event, it will directly execute the program after WFE instruction.

Standby mode

The characteristics of standby mode are shown in the table below:

Table 28 Standby Mode

Characteristics	Instruction
Enter	SLEEPDEEP bit of the core register is set to 1, PDDSCFG bit of the register PMU_CTRL is set to 1, WUEFLG bit is set to 0 and when executing WFI or WFE instruction, the system will enter the standby mode immediately.
Wake-up	Wake up by rising edge of WKUP pin, RTC alarm, wake-up, tamper event or NRST pin external reset and IWDG reset.
Standby	The core will stop working, the peripheral will stop working, and the data in the core register and memory will be lost.
Wake-up delay	Chip reset time.
After wake-up	The program starts executing from the beginning.

7.4.3.2 Reduce the power consumption in run mode

In the run mode, the power consumption can be reduced by reducing the system clock, closing or reducing the peripheral clock on the APB/AHB bus.

7.5 Register Address Mapping

Table 29 PWU Register Address Mapping Table

Register name	Description	Offset address
PMU_CTRL	Power control register	0x00
PMU_CSTS	Power control/state register	0x04

7.6 Register Functional Description

7.6.1 Power control register (PMU_CTRL)

Offset address: 0x00

Reset value: 0x0000 0000 (cleared when waking up from standby mode)

Field	Name	R/W	Description
0	LPDSCFG	R/W	Low Power Deepsleep Configure Configure the working state of the voltage regulator in stop mode. 0: Enable 1: Low-power mode
1	PDDSCFG	R/W	Power Down Deep Sleep Configure When the CPU enters deep sleep, configure the voltage regulator state in standby and stop modes. 0: The voltage regulator is controlled by LPDSCFG bit when entering the stop mode 1: Enter standby mode
2	WUFLGCLR	RC_W1	Wakeup Flag Clear 0: Invalid 1: Clear the wake-up flag after 2 system clock cycles by writing 1
3	SBFLGCLR	RC_W1	Standby Flag Clear 0: Invalid 1: Write 1 to clear the standby flag
4	PVDEN	R/W	Power Voltage Detector Enable 0: Disable 1: Enable

Field	Name	R/W	Description
7:5	PLSEL	R/W	PVD Level Select 0x0: 2.2V 0x1: 2.3V 0x2: 2.4V 0x3: 2.5V 0x4: 2.6V 0x5: 2.7V 0x6: 2.8V 0x7: 2.9V Note: See "Datasheet" for detailed instructions
8	BPWEN	R/W	Backup Domain Write Access Enable Backup area refers to RTC and backup register; write access is disabled after reset, and is allowed after writing 1. 0: Disable 1: Enable
31:9	Reserved		

7.6.2 Power control/state register (PMU_CSTS)

Offset address: 0x04

Reset value: 0x0000 0000 (not cleared when waking up from standby mode)

Compared with the standard APB read, it requires extra APB cycle to read this register.

Field	Name	R/W	Description
0	WUEFLG	R	Wakeup Event Flag This bit is set by hardware, indicating whether wake-up event or RTC alarm wake-up event occurs on WKUP pin 0: Not occurred 1: Occurred Note: Enable the WKUP pin, and an event will be detected when the WKUP pin is at high level.
1	SBFLG	R	Standby Flag This bit is set to 1 by hardware, and can only be cleared by POR/PDR (power-on/power-down reset) or by setting the CSF bit of the power supply control register (PMU_CTRL). 0: Not enter the standby mode 1: Have entered the standby mode
2	PVDOFLG	R	PVD Output Flag Indicate whether V_{DD}/V_{DDA} is higher than the PVD threshold selected by PLSEL[2:0] This bit is valid only when PVD is enabled by PVDEN BIT. 0: V_{DD}/V_{DDA} is higher than PVD threshold 1: V_{DD}/V_{DDA} is lower than PVD threshold Note: This bit is 0 after reset or when entering the standby mode (PVD stops work).
7:3	Reserved		

Field	Name	R/W	Description
15:8	WKUPCFGx	R/W	<p>WKUPx Pin Configure</p> <p>When WKUPx is used as a normal I/O, the event on WKUPx pin cannot wake up the CPU in standby mode; it can wake up CPU only when it is not used as a normal I/O.</p> <p>0: Configure normal I/O 1: Can wake MCU</p> <p>Note: Clear this bit in system reset.</p>
31:16	Reserved		

8 Nested Vector Interrupt Controller (NVIC)

8.1 Full Name and Abbreviation Description of Terms

Table 30 Full Name and Abbreviation Description of Terms

Full name in English	English abbreviation
Non Maskable Interrupt	NMI

8.2 Introduction

The Cortex-M0+ core in the product integrates nested vectored interrupt controller (NVIC), which is closely coupled with the core, and can handle exceptions and interrupts and power management control efficiently and with low delay. Please see *Cortex-M0+ Technical Reference Manual* for more instructions about NVIC.

8.3 Main Characteristics

- (1) 32 maskable interrupt channels (excluding 16 Cortex-M0+ interrupt lines)
- (2) 4 programmable priority levels (use 2-bit interrupt priority level)
- (3) Power management control
- (4) Low-delay exception and interrupt processing
- (5) Realization of system control register

8.4 Interrupt and Exception Vector Table

Table 31 Interrupt and Exception Vector Table

Name	Vector No.	Priority	Vector address	Description
-	-	-	0x0000_0000	Reserved
RST	-	-3	0x0000_0004	Reset
NMI	-	-2	0x0000_0008	Non-maskable interrupt
Hardware fault	-	-1	0x0000_000C	Various hardware faults
SVCall	-	Can be set	0x0000_002C	System service called by SWI instruction
PendSV	-	Can be set	0x0000_0038	Pending system service
SysTick	-	Can be set	0x0000_003C	System tick timer
WWDT	0	Can be set	0x0000_0040	Window watchdog interrupt
PVD_VDDIO2	1	Can be set	0x0000_0044	PVD and VDDIO2 power supply comparator interrupt

Name	Vector No.	Priority	Vector address	Description
RTC	2	Can be set	0x0000_0048	RTC interrupt
FLASH	3	Can be set	0x0000_004C	FLASH interrupt
RCM_CRS	4	Can be set	0x0000_0050	RCM and CRS interrupt
EINT0_1	5	Can be set	0x0000_0054	EINT line [1:0] interrupt
EINT2_3	6	Can be set	0x0000_0058	EINT line [3:2] interrupt
EINT4_15	7	Can be set	0x0000_005C	EINT line [15:4] interrupt
TSC	8	Can be set	0x0000_0060	Touch sensor interrupt
DMA_CH1	9	Can be set	0x0000_0064	DMA channel 1 interrupt
DMA_CH2_3	10	Can be set	0x0000_0068	DMA Channel 2/3 interrupt
DMA_CH4_5_6_7	11	Can be set	0x0000_006C	DMA Channel 4/5/6/7 interrupt
ADC_COMP	12	Can be set	0x0000_0070	ADC and COMP interrupt
TMR1_BRK_UP_TRG_COM	13	Can be set	0x0000_0074	TMR1, BRK, UP, TRG and COM interrupt
TMR1_CC	14	Can be set	0x0000_0078	TMR1 capture/compare interrupt
TMR2	15	Can be set	0x0000_007C	TMR2 interrupt
TMR3	16	Can be set	0x0000_0080	TMR3 interrupt
TMR6_DAC	17	Can be set	0x0000_0084	TMR6 interrupt and DAC underrun interrupt
TMR7	18	Can be set	0x0000_0088	TMR7 interrupt
TMR14	19	Can be set	0x0000_008C	TMR14 interrupt
TMR15	20	Can be set	0x0000_0090	TMR15 interrupt
TMR16	21	Can be set	0x0000_0094	TMR16 interrupt
TMR17	22	Can be set	0x0000_0098	TMR17 interrupt
I2C1	23	Can be set	0x0000_009C	I2C1 interrupt
I2C2	24	Can be set	0x0000_00A0	I2C2 interrupt
SPI1	25	Can be set	0x0000_00A4	SPI1 interrupt
SPI2	26	Can be set	0x0000_00A8	SPI2 interrupt
USART1	27	Can be set	0x0000_00AC	USART1 interrupt
USART2	28	Can be set	0x0000_00B0	USART2 interrupt
USART3_4	29	Can be set	0x0000_00B4	USART3/4 interrupt
CEC_CAN	30	Can be set	0x0000_00B8	CEC and CAN interrupt
USBD	31	Can be set	0x0000_00BC	USBD interrupt

9 External Interrupt and Event Controller (EINT)

9.1 Introduction

The interrupts/events contain internal interrupt/event and external interrupt/event. In this manual, external interrupt refers to the interrupt/event caused by I/O pin input signal, which is EINTx in interrupt vector table; other interrupts are internal interrupts/events.

The events can be divided into hardware events and software events. Hardware events are generated by external/core hardware signals, while software events are generated by instructions.

Interrupts need to go through the interrupt handler function to realize the work to be processed, while events do not need to go through interrupt handler function, and the preset work can be triggered by hardware. The external events output pulse through events such as GPIO, while the internal events trigger another TMR to work, for example, through update event of one TMR.

9.2 Main Characteristics

- (1) Support 32 event/interrupt requests
- (2) Can be configured independently as the line of external/internal event request
- (3) Each event/interrupt line can be masked independently
- (4) The internal line is automatically disabled when the system is not in the stop mode
- (5) Each external event/interrupt line can be triggered independently
- (6) Each external interrupt line has dedicated state bit
- (7) Simulate all external event interrupts

9.3 Functional Description

9.3.1 “External Interrupt and Event” Classification and Difference Points

“External interrupt and event” can be classified into external hardware interrupt, external hardware event, external software event and external software interrupt according to trigger source, configuration and execution process. The difference points are shown in the table below:

Table 32 “External Interrupt and Event” Classification and Difference Points

Name	Trigger source	Configuration and execution process
External hardware interrupt	External signal	<ol style="list-style-type: none"> (1) Set the trigger mode, allow the interrupt request, and enable corresponding peripheral interrupt line (enable in NVIC). (2) When an edge consistent with the configuration is generated on the external interrupt line, an interrupt request will be generated, and the corresponding suspend bit will be set to 1. Write 1 to the corresponding bit of the pending register and the interrupt request will be cleared.

Name	Trigger source	Configuration and execution process
External hardware event	External signal	(1) Set the trigger mode and enable the event line. (2) When an edge consistent with the configuration is generated on the external event line, one event request pulse will be generated, and the corresponding pending bit will not be set to 1.
External software request	Software interrupt register/transmission event (SEV) instruction	(1) Enable the event line. (2) Write 1 to the software interrupt event register of the corresponding event line to generate an event request pulse, and the corresponding pending bit will not be set to 1.
External software interrupt	Software interrupt register	(1) Allow the interrupt request, and enable corresponding peripheral interrupt line (enable in NVIC). (2) Write 1 to the software interrupt event register of the corresponding interrupt line to generate an interrupt request, the corresponding pending bit will be set to 1; write 1 to the corresponding bit of the pending register and the interrupt request will be cleared.

9.3.2 Core Wake-up

Using WFI and WFE instructions can make the core stop working. When WFI instruction is used, any interrupt can wake up the core; when WFE instruction is used, the core can be wakened up by event.

When interrupt is used for wake-up, the interrupt handler function will be triggered, and normal interrupt configuration can wake up the core. When an event is used to wake up the core, the interrupt handler function will not be triggered, which will reduce the wake-up time, and the configuration method is:

- (1) It can trigger an internal interrupt (internal hardware event) but cannot trigger the interrupt handler function for wake-up
 - It can enable an internal interrupt in the peripheral, but cannot enable the corresponding interrupt in NVIC to avoid triggering the interrupt handler function
 - Enable SEVONPEND bit in the system controller of the core, and execute WFE instruction to make the core enter sleep mode
 - Generate an interrupt to wake up the core; when the core recovers from WFE, it is required to clear the pending bit of corresponding peripheral interrupt and the pending bit of peripheral NVIC interrupt channel (clear the pending register in the NVIC interrupt)
- (2) Wake up through EINT line events (external hardware event)
 - Configure EINT line as the event mode
 - Execute WFE instruction to make the core enter the sleep mode
 - Generate an interrupt to wake up the core; when the CPU recovers from WFE, since the pending bit of corresponding event line is not set, it is unnecessary to clear the interrupt pending bit of corresponding peripheral or the NVIC interrupt channel pending bit

9.3.3 External Interrupt and Event Line Mapping

Table 33 External Interrupt and Event Line Mapping

External Interrupt and Event Channel Name	External Interrupt and Event Line No.
PA0/PB0/PC0/PD0/PF0	EINT 0
PA1/PB1/PC1/PD1/PF1	EINT 1

External Interrupt and Event Channel Name	External Interrupt and Event Line No.
...	...
PA15/PB15/PC15/PD15/PF15	EINT 15
PVD output	EINT 16
RTC alarm event	EINT 17
Internal USB D wake-up event	EINT 18
RTC tampering and timestamp event	EINT 19
RTC wake-up event	EINT 20
COMP1 output	EINT 21
COMP2 output	EINT 22
Internal I2C1 wake-up event	EINT 23
Reserved	EINT 24
Internal USART1 wake-up event	EINT 25
Internal USART2 wake-up event	EINT 26
Internal CEC wake-up event	EINT 27
Reserved	EINT 28
Reserved	EINT 29
Reserved	EINT 30
Connect V _{BDIO2} power supply comparator output	EINT 31

9.4 Register Address Mapping

Table 34 External Interrupt/Event Controller Register Mapping

Register name	Description	Offset address
EINT_IMASK	Interrupt mask register	0x00
EINT_EMASK	Event mask register	0x04
EINT_RTEN	Enable the rising edge to trigger the register	0x08
EINT_FTEN	Enable the falling edge to trigger the register	0x0C
EINT_SWINTE	Software interrupt event register	0x10
EINT_IPEND	Interrupt pending register	0x14

9.5 Register Functional Description

9.5.1 Interrupt mask register (EINT_IMASK)

Offset address: 0x00

Reset value: 0x7F84 0000

Field	Name	R/W	Description
31:0	IMASKx	R/W	Interrupt Request Mask on Line x 0: Masked 1: Open

9.5.2 Event mask register (EINT_EMASK)

Offset address: 0x04

Reset value: 0x0000 0000

Field	Name	R/W	Description
31:0	EMASKx	R/W	Event Request Mask on Line x 0: Masked 1: Open

9.5.3 Enable the rising edge to trigger the register (EINT_RTEN)

Offset address: 0x08

Reset value: 0x0000 0000

Field	Name	R/W	Description
17:0	RTENx	R/W	Rising Trigger Event Enable and Interrupt of Line x 0: Disable 1: Enable
18	Reserved		
22:19	RTENx	R/W	Rising Trigger Event Enable and Interrupt of Line x 0: Disable 1: Enable
30:23	Reserved		
31	RTEN31	R/W	Rising Trigger Event Enable and Interrupt of Line 31 0: Disable 1: Enable

Note: Since the external wake-up lines are edge triggered, there should be no burr signal on these lines; when writing EINT_RTEN register, if the rising edge signal is on the external interrupt line, it will not be recognized and the set pending bit will not be set; in the same interrupt line, the rising edge trigger and falling edge trigger can be set at the same time.

9.5.4 Enable the falling edge to trigger the register (EINT_FTEN)

Offset address: 0x0C

Reset value: 0x0000 0000

Field	Name	R/W	Description
17:0	FTENx	R/W	Falling Trigger Event Enable and Interrupt of Line x 0: Disable 1: Enable
18	Reserved		
22:19	FTENx	R/W	Falling Trigger Event Enable and Interrupt of Line x 0: Disable 1: Enable
30:23	Reserved		
31	FTEN31	R/W	Falling Trigger Event Enable and Interrupt of Line 31 0: Disable

Field	Name	R/W	Description
			1: Enable

Note: Since the external wake-up lines are edge triggered, there should be no burr signal on these lines; when writing EINT_FTEN register, if the rising edge signal is on the external interrupt line, it will not be recognized and the set pending bit will not be set; in the same interrupt line, the rising edge trigger and falling edge trigger can be set at the same time.

9.5.5 Software interrupt event register (EINT_SWINTE)

Offset address: 0x10

Reset value: 0x0000 0000

Field	Name	R/W	Description
17:0	SWINTE _x	R/W	Software Interrupt Event on Line x This bit can be set to 1 by software, and be cleared by writing 1 to the corresponding bit of EINT_IPEND. When this bit is 0, the pending bit of EINT_IPEND can be set by writing 1. If EINT_IMASK (EINT_EMASK) is set to open the interrupt (event) request, an interrupt (event) will be generated. 0: No effect 1: Software generates an interrupt (event)
18	Reserved		
22:19	SWINTE _x	R/W	Software Interrupt Event on Line x This bit can be set to 1 by software, and be cleared by writing 1 to the corresponding bit of EINT_IPEND. When this bit is 0, the pending bit of EINT_IPEND can be set by writing 1. If EINT_IMASK (EINT_EMASK) is set to open the interrupt (event) request, an interrupt (event) will be generated. 0: No effect 1: Software generates an interrupt (event)
30:23	Reserved		
31	SWINTE ₃₁	R/W	Software Interrupt Event on Line 31 This bit can be set to 1 by software, and be cleared by writing 1 to the corresponding bit of EINT_IPEND. When this bit is 0, the pending bit of EINT_IPEND can be set by writing 1. If EINT_IMASK (EINT_EMASK) is set to open the interrupt (event) request, an interrupt (event) will be generated. 0: No effect 1: Software generates an interrupt (event)

9.5.6 Interrupt pending register (EINT_IPEND)

Offset address: 0x14

Reset value: 0xXXXX XXXX

Field	Name	R/W	Description
17:0	IPEND _x	RC_W1	Interrupt Pending Occur of Line x Flag Whether the selected trigger request occurs 0: None 1: Occurred When a trigger request on the corresponding edge of EINT occurs on an external interrupt line, it will be set to 1 by hardware; it can be cleared by changing the polarity of the edge detection or by writing 1 to this bit.

Field	Name	R/W	Description
18	Reserved		
22:19	IPENDx	RC_W1	<p>Interrupt Pending Occur of Line x Flag</p> <p>Whether the selected trigger request occurs</p> <p>0: None</p> <p>1: Occurred</p> <p>When a trigger request on the corresponding edge of EINT occurs on an external interrupt line, it will be set to 1 by hardware; it can be cleared by changing the polarity of the edge detection or by writing 1 to this bit.</p>
30:23	Reserved		
31	IPEND31	RC_W1	<p>Interrupt Pending Occur of Line 31 Flag</p> <p>Whether the selected trigger request occurs</p> <p>0: None</p> <p>1: Occurred</p> <p>When a trigger request on the corresponding edge of EINT occurs on an external interrupt line, it will be set to 1 by hardware; it can be cleared by changing the polarity of the edge detection or by writing 1 to this bit.</p>

10 Direct Memory Access (DMA)

10.1 Full Name and Abbreviation Description of Terms

Table 35 Full Name and Abbreviation Description of Terms

Full name in English	English abbreviation
Global	G
Transfer	T
Half	H
Complete	C
Error	E
Channel	CH
Circular	CIR
Peripheral	PER
Increment	I
Memory	M
Priority	PRI
Number	N
Address	ADDR

10.2 Introduction

DMA (Direct Memory Access) can realize direct data transmission between peripheral devices and memory or between memory and memory without CPU intervention, thus saving CPU resources for other operations.

The product has a DMA controller, with seven channels in total. Each channel can manage multiple DMA requests, but each channel can only start one DMA request at the same time. Each channel can set priority, and the arbiter can coordinate the priority of corresponding DMA requests of each DMA channel according to the priority of the channels.

10.3 Main Characteristics

- (1) DMA has seven channels
- (2) There are three data transmission modes: peripheral to memory, memory to peripheral, memory to memory
- (3) Each channel has a special hardware DMA request for connection
- (4) Support software priority and hardware priority when multiple requests occur at the same time
- (5) Each channel has three event flags and independent interrupts
- (6) Support circular transmission mode

(7) The number of data transmission is programmable, up to 65535

10.4 Functional Description

10.4.1 DMA Request

If the peripheral or memory needs to use DMA to transmit data, it is required to first transmit DMA request and wait for DMA approval before data transmission.

DMA has seven channels. Each channel is connected with different peripherals, and each channel has three event flags (DMA half transmission, DMA transmission completion and DMA transmission error). The logic of the three event flags may become a separate interrupt request, and they all support software triggering.

When multiple peripherals request the same channel, it is required to configure the corresponding register to turn on or off the request of each peripheral, so as to ensure that only one peripheral request can be turned on in a channel.

Table 36 DMA Request Mapping Table

Peripheral	Channel 1	Channel 2	Channel 3	Channel 4	Channel 5	Channel 6	Channel 7
TMR1	—	TMR1_CH1 ⁽¹⁾	TMR1_CH2 ⁽¹⁾	TMR1_CH4 TMR1_TRIG TMR1_COM	TMR1_CH3 ⁽¹⁾ TMR1_UP	TMR1_CH1 ⁽²⁾ TMR1_CH2 ⁽²⁾ TMR1_CH3 ⁽²⁾	—
TMR2	TMR2_CH3	TMR2_UP	TMR2_CH2 ⁽¹⁾	TMR2_CH4 ⁽¹⁾	TMR2_CH1	—	TMR2_CH2 ⁽²⁾ TMR2_CH4 ⁽²⁾
TMR3	—	TMR3_CH3	TMR3_CH4 TMR3_UP	TMR3_CH1 ⁽¹⁾ TMR3_TRIG ⁽¹⁾	—	TMR3_CH1 ⁽²⁾ TMR3_TRIG ⁽²⁾	—
TMR6/DAC	—	—	TMR6_UP DAC_Channel1	—	—	—	—
TMR7/DAC	—	—	—	TMR7_UP DAC_Channel2	—	—	—
TMR15	—	—	—	—	TMR15_CH1 TMR15_UP TMR15_TRIG TMR15_COM	—	—
TMR16	—	—	TMR16_CH1 ⁽¹⁾ TMR16_UP ⁽¹⁾	TMR16_CH1 ⁽²⁾ TMR16_UP ⁽²⁾	—	TMR16_CH1 ⁽³⁾ TMR16_UP ⁽³⁾	—
TMR17	TMR17_CH1 ⁽¹⁾ TMR17_UP ⁽¹⁾	TMR17_CH1 ⁽²⁾ TMR17_UP ⁽²⁾	—	—	—	—	TMR17_CH1 ⁽³⁾ TMR17_UP ⁽³⁾
ADC	ADC ⁽¹⁾	ADC ⁽²⁾	—	—	—	—	—
SPI	-	SPI1_RX	SPI1_TX	SPI2_RX ⁽¹⁾	SPI2_TX ⁽¹⁾	SPI2_RX ⁽²⁾	SPI2_TX ⁽²⁾
USART	-	USART1_TX ⁽¹⁾ USART3_TX ⁽²⁾	USART1_RX ⁽¹⁾ USART3_RX ⁽²⁾	USART1_TX ⁽²⁾ USART2_TX ⁽¹⁾	USART1_RX ⁽²⁾ USART2_RX ⁽¹⁾	USART2_RX ⁽²⁾ USART3_RX ⁽¹⁾ USART4_RX	USART2_TX ⁽²⁾ USART3_TX ⁽¹⁾ USART4_TX
I2C	-	I2C1_TX ⁽¹⁾	I2C1_RX ⁽¹⁾	I2C2_TX	I2C2_RX	I2C1_TX ⁽²⁾	I2C1_RX ⁽²⁾

Note: (1) This DMA request is mapped to the DAM channel only when the corresponding bit of SYSCFG_CFG1 register is cleared.

(2) This DMA request is mapped to the DAM channel only when the corresponding remapping bit of SYSCFG_CFG1 register is set.

(3) Only when the TMRxDMARMP2 bit is set by the corresponding remapping bit of SYSCFG_CFG1 register, can this DMA request be mapped to this DMA channel.

10.4.2 DMA Channel

10.4.2.1 Transmission data are programmable

The data transmitted by DMA are programmable, up to 65535, and the transmission data bit width of peripherals and memory can be set by configuring PERSIZE bit and MSIZE bit of DMA_CHCFGx register.

10.4.2.2 Transmission width and alignment method are programmable

Programmable data transmission width DMA transmission operations:

Figure 9 Transmission Width with Source of 8bits and Target of 8bits

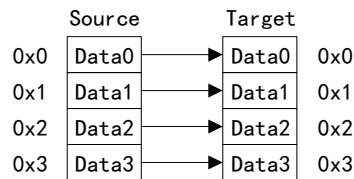

Figure 10 Transmission Width with Source of 8bits and Target of 16bits

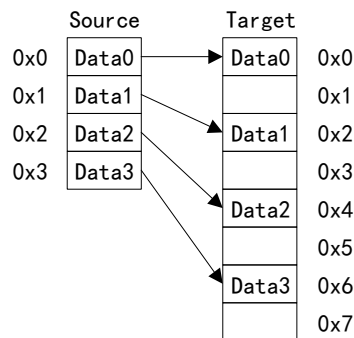

Figure 11 Transmission Width with Source of 8bits and Target of 32bits

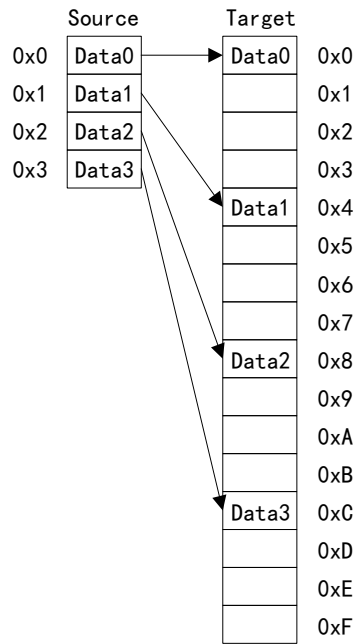

Figure 12 Transmission Width with Source of 32bits and Target of 8bits

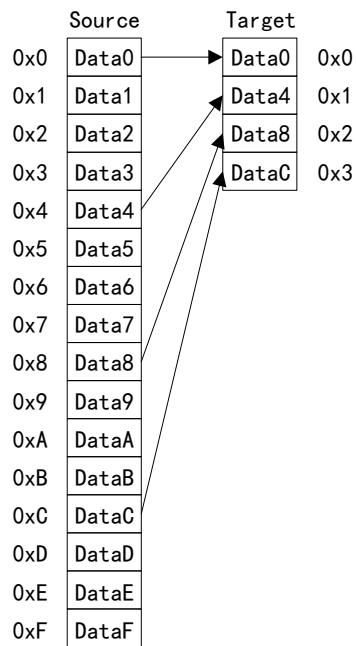

Figure 13 Transmission Width with Source of 16bits and Target of 16bits

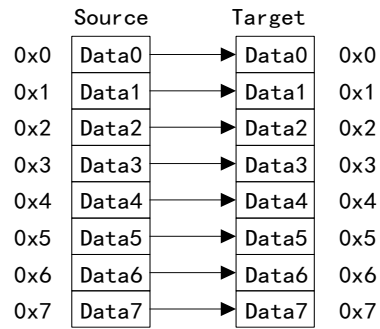

Figure 14 Transmission Width with Source of 16bits and Target of 32bits

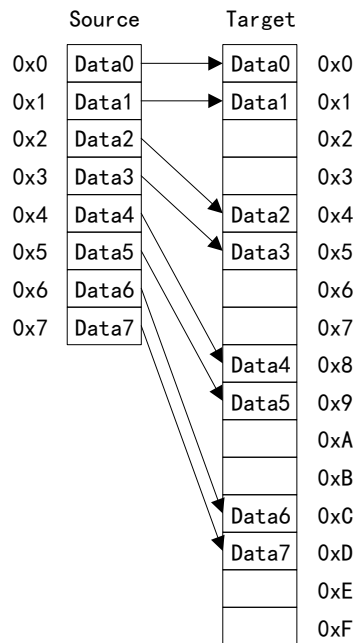
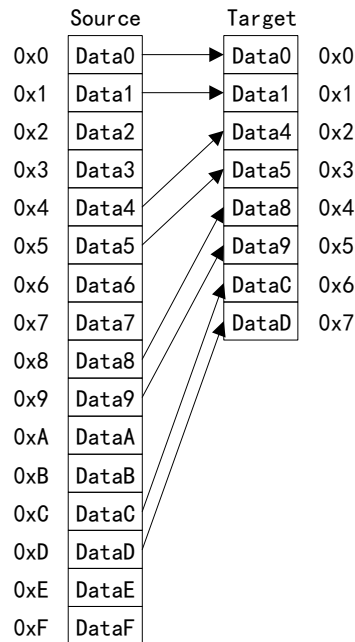

Figure 15 Transmission Width with Source of 32bits and Target of 16bits



10.4.2.3 Address setting

The transmission address supports two modes: fixed mode and pointer increment mode.

Transmission address pointer increment mode

The automatic pointer increment of peripheral and memory is completed through the PERIMODE bit and MIMODE bit of configuration register DMA_CHCFGx. The next address to be transmitted is the one by adding the increment to the previous address. The increment depends on the selected data width.

10.4.2.4 Transmission mode

There are two channel configuration modes: non-circular mode and circular mode.

Non-circular mode

When the data transmission is finished, the DMA operation will not be performed any more, and the new DMA transmission will be started. When the DMA channel is not working, the register DMA_CHNDATAx will rewrite the transmission value.

Circular mode

After data transmission, the content of the register DMA_CHNDATAx will be automatically reloaded to the previously configured value, and the peripheral address register DMA_CHPADDRx and the memory address register DMA_CHMADDRx will also be reloaded as the initial base address.

The configuration method is as follows:

- Set the CIRMODE bit of the configuration register DMA_CHCFGx to 1 to turn on the circular mode;
- This mode is used to process continuous peripheral requests. When the number of data transmission becomes 0, it will automatically return

to the initial value and continue DMA operation until the CIRMODE bit is cleared and the system exits the circular mode.

10.4.2.5 DMA request priority setting

Arbitrator

When multiple DMA channel requests occur, an arbiter is needed to manage the response sequence. Management is divided into two stages: the first stage is software stage, which is divided into the highest, high, medium and low priority; the second stage is hardware stage, and under the condition of the same software priority, the lower the channel number is, the higher the priority is.

10.4.2.6 Transmission direction

Support three directions: from memory to memory, from memory to peripheral, and from peripheral to memory.

If the write operation (target address) is performed on the memory, the memory includes external RAM supported by internal SRAM (such as external SRAM); if the read operation (source address) is performed on the memory, the address includes internal FLASH and internal SRAM.

Examples of “from memory to memory” configuration are as follows:

- The M2MMODE bit of the configuration register DMA_CHCFGx is set to put the memory to the memory mode;
- The DMA operation in this mode is performed under the condition of no peripheral request. The CHEN bit of the configuration register DMA_CHCFGx is set to 1, and after the channel is opened, the data transmission will start and when the transmission quantity register DMA_CHNDATAx becomes 0, the transmission is over.

10.4.3 Interrupt

Each DMA channel has three types of interrupt events, which are half transmission (HT), transmission completion (TC) and transmission error (TE).

- (1) The interrupt event flag bit for half transmission is HTFLG, and the interrupt enable control bit is HTINTEN
- (2) The interrupt event flag bit for transmission completion is TCFLG, and the interrupt enable control bit is TCINTEN
- (3) The interrupt event flag bit for transmission error is TERRFLG, and the interrupt enable control bit is TERRINTEN

10.5 Register Address Mapping

Table 37 DMA Register Address Mapping Table

Register name	Description	Offset address
DMA_INTSTS	DMA interrupt state register	0x00
DMA_INTFCLR	DMA interrupt flag clear register	0x04
DMA_CHCFGx	DMA Channel x configuration register	0x08+20 x
DMA_CHNDATAx	DMA Channel x transmission quantity register	0x0C+20 x

DMA_CHPADDRx	DMA Channel x peripheral address register	0x10+20 x
DMA_CHMADDRx	DMA Channel x memory address register	0x14+20 x

10.6 Register Functional Description

10.6.1 DMA interrupt state register (DMA_INTSTS)

Offset address: 0x00

Reset value: 0x0000 0000

Field	Name	R/W	Description
24,20,16, 12,8,4,0	GINTFLGx	R	Channel x Global Interrupt Occur Flag (x=1...7) Indicate whether TC, HT or TE interrupt is generated on the channel; these bits are set to 1 by hardware; write 1 and clear on the corresponding bit of DMA_INTFCLR. 0: Not generate 1: Generate
25,21,17, 13,9,5,1	TCFLGx	R	Channel x All Transfer Complete Flag (x=1...7) Indicate whether the transmission completion interrupt (TC) is generated on the channel; these bits are set to 1 by hardware; write 1 and clear on the corresponding bit of DMA_INTFCLR. 0: Not completed 1: Completed
26,22,18, 14,10,6,2	HTFLGx	R	Channel x Half Transfer Complete Flag (x=1...7) Indicate whether the half transmission interrupt (HT) is generated on the channel; these bits are set to 1 by hardware; write 1 and clear on the corresponding bit of DMA_INTFCLR. 0: Not generate 1: Generate
27,23,19, 15,11,7,3	TERRFLGx	R	Channel x Transfer Error Occur Flag (x=1...7) Indicate whether the transmission error interrupt (TE) is generated on the channel; these bits are set to 1 by hardware; write 1 and clear on the corresponding bit of DMA_INTFCLR. 0: Not generate 1: Generate
31:28	Reserved		

10.6.2 DMA interrupt flag clear register (DMA_INTFCLR)

Offset address: 0x04

Reset value: 0x0000 0000

Field	Name	R/W	Description
24,20,16,12, 8,4,0	GINTCLRx	W	Channel x Global Interrupt Occur Flag Clear (x=1...7) Clear the corresponding GINTFLG, TCFLG, HTFLG and TERRFLG flags in the interrupt state register. 0: Invalid 1: Clear the GINTFLG flag

Field	Name	R/W	Description
25,21, 17,13, 9,5,1	TCCLR _x	W	Channel x Transfer Complete Clear (x=1...7) Clear the corresponding TCFLG flag in interrupt state register. 0: Invalid 1: Clear the TCFLG flag
26,22 18,14, 10,6,2	HTCLR _x	W	Channel x Half Transfer Complete Clear (x=1...7) Clear the corresponding HTFLG flag in interrupt state register. 0: Invalid 1: Clear the HTFLG flag
27,23, 19,15, 11,7,3	TERRCLR _x	W	Channel x Transfer Error Occur Clear (x=1...7) Clear the corresponding TERRFLG flag in interrupt state register. 0: Invalid 1: Clear the TERRFLG flag
31:28	Reserved		

10.6.3 DMA Channel x configuration register (DMA_CHCFG_x) (x=1...7)

Offset address: 0x08+20 x (channel number-1)

Reset value: 0x0000 0000

Field	Name	R/W	Description
0	CHEN	R/W	DMA Channel Enable 0: Disable 1: Enable
1	TCINTEN	R/W	All Transfer Complete Interrupt Enable 0: Disable 1: Enable
2	HTINTEN	R/W	Half Transfer Complete Interrupt Enable 0: Disable 1: Enable
3	TERRINTEN	R/W	Transfer Error Occur Interrupt Enable 0: Disable 1: Enable
4	DIRCFG	R/W	Data Transfer Direction Configure 0: Read from peripheral to memory 1: Read from memory to peripheral
5	CIRMODE	R/W	Circular Mode Enable 0: Disable 1: Enable
6	PERIMODE	R/W	Peripheral Address Increment Mode Enable 0: Disable 1: Enable
7	MIMODE	R/W	Memory Address Increment Mode Enable 0: Disable 1: Enable
9:8	PERSIZE	R/W	Peripheral Data Size Configure 00: 8 bits 01: 16 bits 10: 32 bits 11: Reserved
11:10	MSIZE	R/W	Memory Data Size Configure 00: 8 bits 01: 16 bits 10: 32 bits 11: Reserved
13:12	CHPL	R/W	Channel Priority Level Configure 00: Low

Field	Name	R/W	Description
			01: Medium 10: High 11: Highest
14	M2MMODE	R/W	Memory to Memory Mode Enable 0: Disable 1: Enable
31:15	Reserved		

10.6.4 DMA Channel x transmission quantity register (DMA_CHNDATAx) (x=1...7)

Offset address: 0x0C+20 x (channel number-1)

Reset value: 0x0000 0000

Field	Name	R/W	Description
15:0	NDATAT	R/W	Number of Data to Transfer Setup This register indicates the number of bytes to be transmitted. The number of data transmission ranges from 0 to 65535. This register can only be written when the channel is not working; once the channel is enabled, the register will be read-only, indicating the number of remaining bytes to be transmitted. The register will decrease after each DMA is transmitted; when the data transmission is completed, the register will change to 0, or when the channel is configured to auto reload mode, it will be automatically reloaded to the previously configured value; if the register is 0, data transmission will not occur regardless of whether the channel is turned on or not.
31:16	Reserved		

10.6.5 DMA Channel x peripheral address register (DMA_CHPADDRx) (x=1...7)

Offset address: 0x10+20 x (channel number-1)

Reset value: 0x0000 0000

This register cannot be written when the channel is turned on (CHEN=1 for DMA_CHCFGx).

Field	Name	R/W	Description
31:0	PERADDR	R/W	Peripheral Basic Address Setup When PERSIZE= '01' (16 bits) and PERADDR[0] bit is not used, it will be aligned with 16-bit address automatically during transmission. When PERSIZE= '10' (32 bits) and PERADDR[1:0] bit is not used, it will be aligned with 32-bit address automatically during transmission.

10.6.6 DMA Channel x memory address register (DMA_CHMADDRx) (x=1...7)

Offset address: 0x14+20 x (channel number-1)

Reset value: 0x0000 0000; when the channel is turned on (CHEN=1 for DMA_CHCFGx), this register cannot be written.

Field	Name	R/W	Description
-------	------	-----	-------------

Field	Name	R/W	Description
31:0	MEMADDR	R/W	<p>Memory Basic Address Setup</p> <p>When MSIZE= '01' (16 bits) and MEMADDR[0] bit is not used, it will be aligned with 16-bit address automatically during transmission.</p> <p>When MSIZE= '10' (32 bits) and MEMADDR[1:0] bit is not used, it will be aligned with 32-bit address automatically during transmission.</p>

11 Debug MCU (DBGMCU)

11.1 Full Name and Abbreviation Description of Terms

Table 38 Full Name and Abbreviation Description of DBGMCU Terms

Full name in English	English abbreviation
Frame Clock	FCLK
Serial Wire / JTAG Debug Port	SWJ-DP
Data Watchpoint Trigger	DWT
Break Point Unit	BPU

11.2 Introduction

APM32A0x MCU series uses Arm® Cortex® -M0+ core, and Arm® Cortex® -M0+ core includes hardware debug module and supports complex debug operation. During debugging, the module can make the running core stop at breakpoint, and achieve the effect of querying the internal state of the core and the external state of the system, and after the query is completed, the core and peripheral operation can be restored to continue to execute the program.

Supported debugging interface: serial interface

Note: The hardware debug interface included in Arm® Cortex® -M0 core is subset of Arm CoreSight development tool set. Please refer to *Cortex®-M0+ (Version r1p1) Technical Reference Manual (TRM)* and *CoreSight development Tool Set (Version r1p0) TRM* for more information about debug function of Arm® Cortex®-M0+ core.

11.3 Main Characteristics

- (1) Flexible debug pin assignment
- (2) MCU debug box (support low-power mode, control peripheral clock, etc.)

Figure 16 APM32A0xx Level and Arm® Cortex®-M0+ Level Debugging Block Diagram

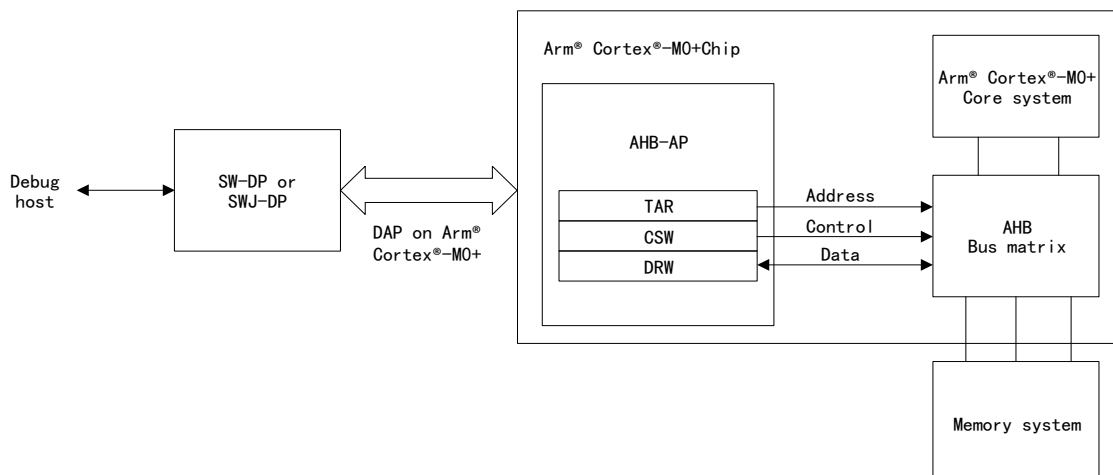

11.4 Functional Description

- (1) Realize the on-line programming and debugging of the chip
- (2) Using KEIL/IAR and other software to achieve on-line debugging, downloading and programming
- (3) Flexible implementation of production of bus-off programmer

11.5 Register Address Mapping

Table 39 DBGMCU Register Address Mapping

Register name	Description	Address
DBGMCU_IDCODE	Debug MCU device ID register	0x40015800
DBGMCU_CFG	Debug MCU configuration register	0x40015804
DBGMCU_APB1F	Debug MCU APB1 freeze register	0x40015808
DBGMCU_APB2F	Debug MCU APB2 freeze register	0x4001580C

11.6 Register functional description

11.6.1 Debug MCU device ID register (DBGMCU_IDCODE)

Address: 0x40015800

Only support 32-bit access

Reset value: 0xXXXX XXXX

Field	Name	R/W	Description
11:0	EQR	R	Equipment Recognition This field indicates device ID APM32A07x microcontroller series: APM32A072xBTx series products: 0x448 The debugger/programming tool identifies chips by QR (11:0).
15:12	Reserved		
31:16	WVR	R	Wafer Version Recognition This field indicates the device version APM32A07x microcontroller series: APM32 F072x8xB series products Version A: 0x1000 Version Z: 0x1001 Version B: 0x2000 Version Y or 1: 0x2001

11.6.2 Device MCU chmittgd register (DBGMCU_CFG)

This register allows MCU to be configured during debugging and supports low-power mode.

It is reset asynchronously by POR (not reset by system), and it can be written by debugger through system reset.

If the debugging host does not support these characteristics, the user software can write to these registers.

Only support 32-bit access

Address: 0x40015804

Reset value: 0x0000 (unaffected by system reset)

Field	Name	R/W	Description
0	Reserved		

Field	Name	R/W	Description
1	STOP_CLK_STS	R/W	<p>Debug Stop Mode Configure</p> <p>0: In the stop mode when both FCLK and HCLK are turned off, all clocks will be disabled by clock controller. When exiting the stop mode, the clock configuration is the same as that after reset (the clock is provided by the 8MHz internal RC oscillator HSICLK), so the software needs to reconfigure the clock controller to start PLL, crystal oscillator, etc.</p> <p>1: In the stop mode when both FCLK and HCLK are turned on, both FCLK and HCLK are provided by internal RC oscillator. The internal RC oscillator remains or is active in the stop mode. When it exits the stop mode, the software must reconfigure the clock controller to enable PLL, crystal oscillator, etc.</p>
2	STANDBY_CLK_STS	R/W	<p>Debug Standby Mode</p> <p>0: When both FCLK and HCLK are turned off, the digital part is not powered on. From the software level, it indicates that when the MCU just exits from the standby mode, others exit the debug mode, which is the same as reset</p> <p>1: When both FCLK and HCLK are turned on, the digital part is powered on, and the internal RC oscillator provides FCLK and HCLK clocks. Besides, the MCU exits the standby mode through system reset, which is the same as reset.</p>
31:3	Reserved		

11.6.3 Debug MCU APB1 freeze register (DBGMCU_APB1F)

This register is used to configure MCU during debugging.

Involve some APB peripherals:

- Freeze the timer counter
- Freeze I2C SMBus timeout
- Freeze supporting system window regulators and independent watchdog counters

This register is reset asynchronously by POR (instead of system reset) and can be written by the debugger through system reset.

Only support 32-bit access

Address: 0x40015808

Reset value: 0x0000 (unaffected by system reset)

Field	Name	R/W	Description
0	TMR2_STS	R/W	<p>Configure TMR2 Work Status When Core is in Halted Whether TMR2 timer continues to work when the core stops work</p> <p>0: Continue to work</p> <p>1: Stop working</p>
1	TMR3_STS	R/W	<p>Configure TMR3 Work Status When Core is in Halted Whether TMR3 counter continues to work when the core stops work</p> <p>0: Continue to work</p> <p>1: Stop working</p>
3:2	Reserved		
4	TMR6_STS	R/W	<p>Configure TMR6 Work Status When Core is in Halted Whether TMR6 counter continues to work when the core stops work</p> <p>0: Continue to work</p> <p>1: Stop working</p>

Field	Name	R/W	Description
5	TMR7_STS	R/W	Configure TMR7 Work Status When Core is in Halted Whether TMR7 counter continues to work when the core stops work 0: Continue to work 1: Stop working
7:6	Reserved		
8	TMR14_STS	R/W	Configure TMR14 Work Status When Core is in Halted Whether TMR14 counter continues to work when the core stops work 0: Continue to work 1: Stop working
9	Reserved		
10	RTC_STS	R/W	Configure RTC Work Status When Core Is in Halted Whether RTC counter continues to work when the core stops work 0: Continue to work 1: Stop working
11	WWDT_STS	R/W	Configure Window Watchdog Work Status When Core Is in Halted Whether WWDT continues to work when the core is halted 0: Continue to work 1: Stop working
12	IWDT_STS	R/W	Configure Independent Watchdog Work Status When Core Is in Halted Whether IWDT continues to work when the core is halted 0: Continue to work 1: Stop working
20:13	Reserved		
21	I2C1_SMBUS_TIMEOUT_STS	R/W	Configure I2C1_SMBUS_TIMEOUT Work Status When Core Is in Halted Whether I2C1_SMBUS_TIMEOUT continues to work when the core stops work 0: Work normally 1: Freeze the timeout mode of SMBUS
24:22	Reserved		
25	CAN_STS	R/W	Configure Controller Area Network Work Status When Core Is in Halted Whether CAN continues to work when the core is halted 0: Work normally 1: Freeze the receiver transmitter of CAN
31:26	Reserved		

11.6.4 Debug MCU APB2 freeze register (DBGMCU_APB2F)

This register is used to configure MCU during debugging.

Involve some APB peripherals:

- Freeze the timer counter

This register is reset asynchronously by POR (instead of system reset) and can be written by the debugger through system reset.

Only support 32-bit access

Address: 0x4001580C

Reset value: 0x0000 (unaffected by system reset)

Field	Name	R/W	Description
10:0	Reserved		
11	TMR1_STS	R/W	Configure TMR1 Work Status When Core is in Halted Whether TMR1 counter continues to work when the core stops work 0: Continue to work 1: Stop working
15:12	Reserved		
16	TMR15_STS	R/W	Configure TMR15 Work Status When Core is in Halted Whether TMR15 counter continues to work when the core stops work 0: Continue to work 1: Stop working
17	TMR16_STS	R/W	Configure TMR16 Work Status When Core is in Halted Whether TMR16 counter continues to work when the core stops work 0: Continue to work 1: Stop working
18	TMR17_STS	R/W	Configure TMR17 Work Status When Core is in Halted Whether TMR17 counter continues to work when the core stops work 0: Continue to work 1: Stop working
31:19	Reserved		

12 General-purpose/Alternate function Input/Output Pin (GPIO/AFIO)

12.1 Full Name and Abbreviation Description of Terms

Table 40 Full Name and Abbreviation Description of Terms

Full name in English	English abbreviation
P-channel Metal Oxide Semiconductor	P-MOS
N-channel Metal Oxide Semiconductor	N-MOS

12.2 Main Characteristics

- (1) Input mode
 - Floating input
 - Pull-up input
 - Pull-down input
- (2) Output mode
 - Push-pull output
 - Open-drain output
 - Configurable maximum output rate
- (3) Multiplexing mode
 - Push-pull multiplexing function
 - Open-drain multiplexing function
- (4) Analog mode
- (5) GPIO can be used as external interrupt/wake-up line
- (6) Support locking I/O configuration function

12.3 Structure Block Diagram

Figure 17 GPIO Structure Block Diagram

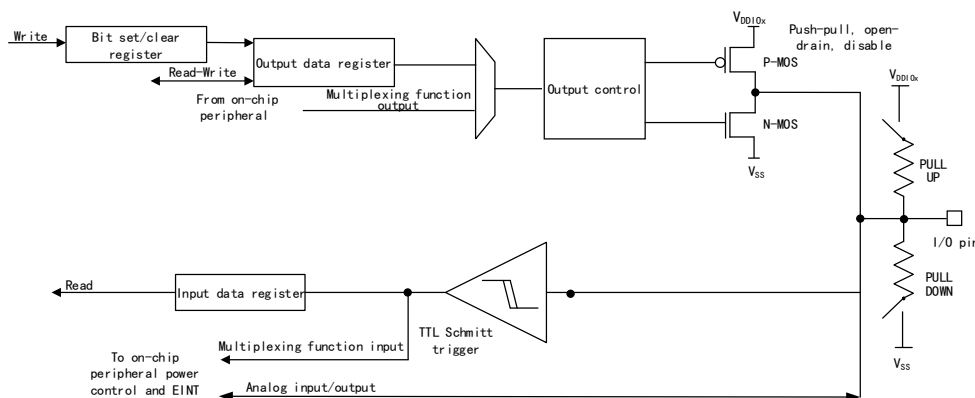

12.4 Functional Description

Each pin of GPIO can be configured as pull-up, pull-down, floating and analog input, or push-pull/open-drain output input mode and multiplexing function through software. All GPIO interfaces have external interrupt capability.

12.4.1 IO status during Reset and just after Reset

During and just after GPIO reset, if the multiplexing function is not turned on, the I/O port will be configured as floating input mode.

After reset, the debug pin is in AF pull-up/pull-down state:

- PA14: SWCLK in pull-up mode
- PA13: SWDIO in pull-down mode

12.4.2 Input Mode

In the input mode, it can be set as pull-up, pull-down, floating and analog input.

When GPIO is configured as input mode, all GPIO pins have internal weak pull-up and weak pull-down resistors, which can be activated or disconnected.

Pull-up, pull-down, and floating modes

In (pull-up, pull-down, floating) input mode

- Schmitt trigger is opened,
- Disable output buffer
- By configuring the pull-up/pull-down register GPIOx_PUPD, select whether to use pull-up/pull-down resistors
- The input data register GPIOx_IDATA captures the data on I/O pin in each AHB clock cycle.
- Read I/O state through the input data register GPIOx_IDATA

The initial level state of the floating input mode is uncertain and is easy to be disturbed by the outside; when connecting the equipment, it is determined by the external input level (except for the very high impedance).

The initial level state of pull-up/pull-down input mode is high level if pull-up, and low level if pull-down; when connecting the equipment, it is determined by the external input level and load impedance.

Figure 18 I/O Structure in Input Mode

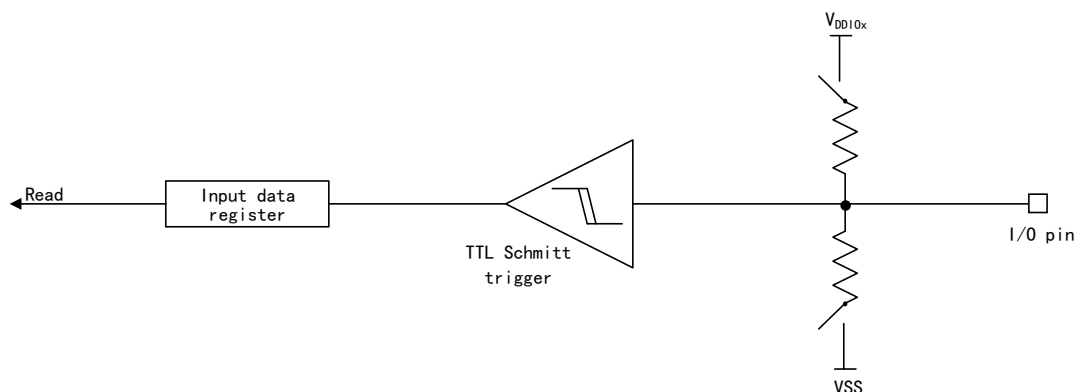

12.4.3 Output Mode

In the output mode, it can be set as push-pull output and open-drain output.

When GPIO is configured as the output pin, the output speed of the port can be configured and the output drive mode (push-pull / open-drain) can be selected.

In output mode

- Schmitt trigger is opened,
- Activate the output buffer,
- By configuring the pull-up/pull-down register GPIOx_PUPD, select whether to use pull-up/pull-down resistors
- Push-pull mode:
 - Double MOS transistor works by turns and the output data register can control the high and low level of I/O output;
 - Read the finally written value through the output data register GPIOx_ODATA
- Open-drain mode:
 - Only N-MOS works, and the output data register can control I/O output high resistance state or low level
 - The input data register GPIOx_IDATA captures the data on I/O pin in each AHB clock cycle
 - Read the actual I/O state through the input data register GPIOx_IDATA

Figure 19 I/O Structure in Output Mode

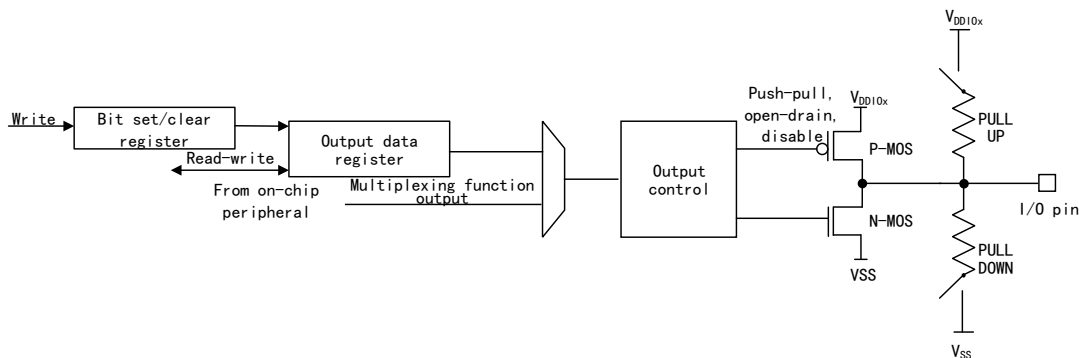

12.4.4 Multiplexing Mode

In multiplexing mode, it can be set as push-pull multiplexing and open-drain multiplexing

In push-pull/open-drain multiplexed mode

- Open the output buffer
- Output buffer is driven by peripheral
- Activate 98schmitt trigger input
- By configuring the pull-up/pull-down register GPIOx_PUPD, select whether to use pull-up/pull-down resistors
- The data on the I/O pin is sampled in each AHB clock cycle and stored in the port input state register
- Read the actual I/O state through the input data register GPIOx_IDATA

Figure 20 I/O Structure in Multiplexing Mode

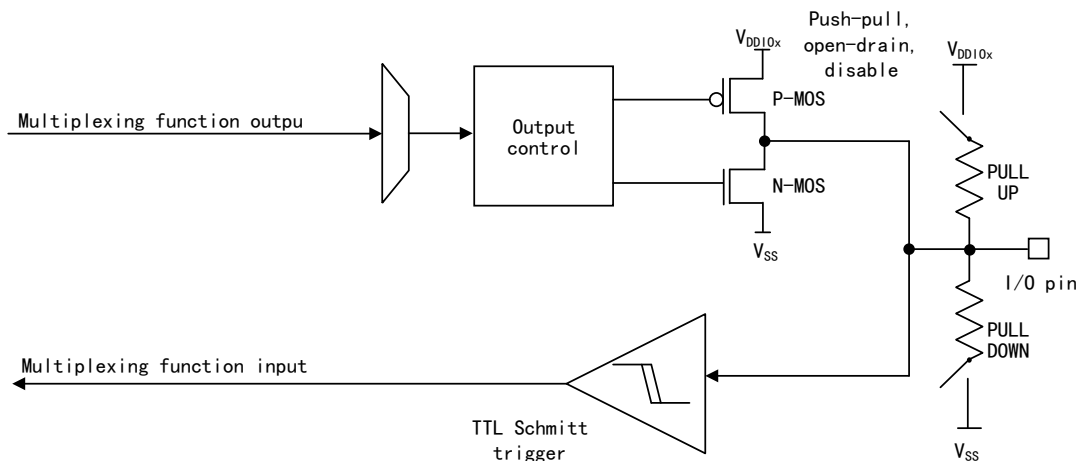

12.4.5 Analog Mode

In analog function mode

- Disable output buffer
- The input of Schmitt trigger is disabled, and the output value of Schmitt trigger is forced to be 0
- Weak pull-up and pull-down resistors are disabled
- Read the value of the input state register to be 0

Figure 21 Analog Function I/O Structure

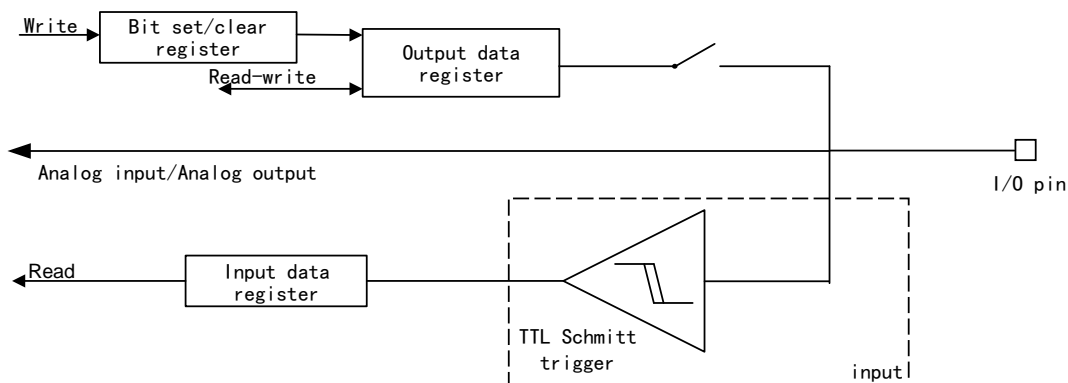

12.4.6 External Interrupt/Wake-up Line

All GPIO ports have external interrupt function. If you want to use external interrupt line, the port must be configured as input mode.

12.4.7 I/O Data Bit Processing

GPIO port set/reset register (GPIOx_BSC) allows set/reset operation for each bit of the output data register (GPIOx_ODATA). The valid data width of the set/reset register is double the valid data width of GPIOx_ODATA.

Writing 0 to any bit in GPIOx_BSC will not affect the value of the GPIOx_ODATA register. BSy and BCy bits of GPIOx_BSC are set to 1 for the same time,

operation of BSY bit has the priority. GPIOx_BSC register can change the corresponding bit of the GPIOx_ODATA register, and GPIOx_ODATA bit can be accessed directly from GPIOx_BSC register.

When the access mechanism is set or reset by GPIOx_ODATA through GPIOx_BSC register, it is not necessary to turn off the interrupt by software to access GPIOx_ODATA.

12.4.8 Multiplexing Function and Remapping

Multiplexer

The multiplexer is used to connect the I/O port line of the device to the embedded peripheral module, and it can only be one-to-one at the same time.

Each I/O pin is equipped with a multiplexer. The multiplexer has up to 16 multiplexing function inputs, but in fact it uses up to 8 (AF7), which is configured by GPIOx_ALFL and GPIOx_ALFH registers. When I/O pin is reset, all pin ports are connected to AF0.

Remapping

Each peripheral has multiple multiplexing functions, but only one multiplexing function input can be selected for a pin, so the multiplexing function of the peripheral can be mapped to other I/O pins, that is, the multiplexing function signal can be reassigned to a pin address.

The multiplexing function and remapping address table of pins are shown in the data manual.

I/O multiplexing configuration

When I/O port is connected to the peripheral multiplexing function, the following debugging needs to be done:

- After reset, the pin is configured with multiplexing function
- I/O port is configured as input, output or analog input
- The I/O port is connected to the defined AFx
- Configure pin pull-up/pull-down and output speed
- Configure I/O as multiplexing function in GPIOx_MODE

When the I/O port is configured with multiplexing function, its input and output mode is as follows:

- Open the output buffer
- Output buffer is driven by peripheral
- Activate 100chmitt trigger input
- By configuring the pull-up/pull-down register GPIOx_PUPD, select whether to use pull-up/pull-down resistors
- The data on the I/O pin is sampled in each AHB clock cycle and stored in the port input state register
- Read the actual I/O state through the input data register GPIOx_IDATA

The multiplexing mode I/O structure is shown in the figure below:

Figure 22 I/O Structure in Multiplexing Mode

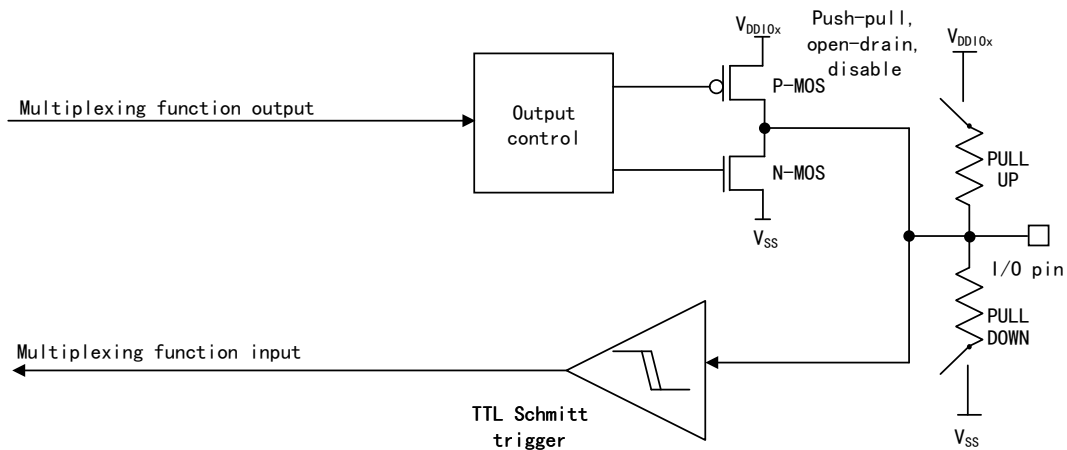

12.4.9 GPIO Locking Function

The locking mechanism of GPIO can protect the configuration of I/O port.

Write sequence (specific) to GPIOx_LOCK register so as to freeze the control register of Port A and Port B. If you want to write GPIOx_LOCK register, a specific write/read sequence should be transmitted.

I/O configuration can be locked by configuring the lock register (GPIOx_LOCK). When a port bit executes the locking program, the configuration of port bit cannot be modified before the next reset.

12.4.10 HSECLK or LSECLK pin is used as GPIO

By configuring HSEEN/LSEEN in RCM_CTRL1 and RCM_BDCTRL registers, set whether to turn on HSECLK/LSECLK RC oscillator.

When HSECLK/LSECLK RC oscillator is turned on, the oscillator controls the related pins, and the related pins are unrelated to GPIO configuration; when HSECLK/LSECLK RC oscillator is turned off, the related oscillators can be used as general GPIO interface.

12.4.11 GPIO is used in RTC power supply domain

When the core power supply domain is powered off, it will lose PC13/PC14/PC15 GPIO function, and at this time, if the configuration of GPIO is not configured by RTC, PC13/14/PC15 pin will be set as analog input mode.

See 21.5.1 for detailed information about RTC control I/O pin.

12.5 Register Address Mapping

Table 41 GPIO Register Address Mapping

Register name	Description	Offset address
GPIOx_MODE	Port mode register	0x00

GPIOx_OMODE	Port output mode register	0x04
GPIOx_OSSEL	Port output speed register	0x08
GPIOx_PUPD	Port pull-up/pull-down register	0x0C
GPIOx_IDATA	Port bit input data register	0x10
GPIOx_ODATA	Port bit output clear register	0x14
GPIOx_BSC	Port set/reset register	0x18
GPIOx_LOCK	Port lock register	0x1C
GPIOx_ALFL	Port multiplexing function low-8-bit register	0x20
GPIOx_ALFH	Port multiplexing function high-8-bit register	0x24
GPIOx_BR	Port reset register	0x28

12.6 Register Functional Description

12.6.1 Port mode register (GPIOx_MODE) (x=A...F)

Offset address: 0x00

Reset value: 0x2800 000 for Port A

0x0000 000 for other ports

Field	Name	R/W	Description
31:0	MODEy[1:0]	R/W	PortxPin y Mode Configure (y=0...15) 00: Input mode (state after reset) 01: General output mode 10: Multiplexing function mode 11: Analog mode

12.6.2 Port output mode register (GPIOx_OMODE) (x=A...F)

Offset address: 0x04

Reset value: 0x0000 0000

Field	Name	R/W	Description
15:0	OMODEy	R/W	PortxPin y Output Mode Configure (y=0...15) 0: Push-pull output (reset state) 1: Open-drain output
31:16	Reserved		

12.6.3 Port output speed register (GPIOx_OSSEL) (x=A...F)

Offset address: 0x08

Reset value: 0x0000 0000

Field	Name	R/W	Description
31:0	OSSELy[1:0]	R/W	PortxPin y Output Speed Select (y=0...15) x0: Low speed 01: Medium speed 11: High speed The speed of configuration I/O port is written by software

12.6.4 Port pull-up/pull-down register (GPIOx_PUPD) (x=A...F)

Offset address: 0x0C

Reset value: 0x2400 000 for Port A

0x0000 000 for other ports

Field	Name	R/W	Description
31:0	PUPDy[1:0]	R/W	PortxPin y Pull-up/Pull-down Configure (y=0...15) These bits are written by software to configure pull-up/pull-down of the port bit 00: Pull-up/Pull-down is disabled 01: Pull up 10: Pull down 11: Reserved

12.6.5 Port bit input data register (GPIOx_IDATA) (x=A...F)

Offset address: 0x10

Reset value: 0x0000 XXXX

Field	Name	R/W	Description
15:0	IDATAy	R	PortxPin y Input Data (y=0...15) These bits can only be read to store the input values of the corresponding I/O ports
31:16	Reserved		

12.6.6 Port bit output data register (GPIOx_ODATA) (x=A...F)

Offset address: 0x14

Reset value: 0x0000 0000

Field	Name	R/W	Description
15:0	ODATAy	R/W	PortxPin y Output Data (y=0...15) Read and write operation can be performed by software For atomic bit set/clear, the ODATAy bit can be set separately by writing to GPIOx_BSC or GPIOx_BR register
31:16	Reserved		

12.6.7 Port set/reset register (GPIOx_BSC) (x=A...F)

Offset address: 0x18

Reset value: 0x0000 0000

Field	Name	R/W	Description
15:0	BSy	W	PortxPin y Set bit (y=0...15) These bits can only perform write operation, and the value of 0x0000 is returned when reading these bits. These bits are used to affect the corresponding ODATAy bits 0: No effect 1: Set the corresponding ODATAy bit
31:16	BCy	W	PortxPin y Reset Bit (y=0...15) These bits can only perform write operation, and the value of 0x0000 is returned when reading these bits. These bits are used to affect the corresponding ODATAy bits 0: No effect 1: Corresponding ODATAy bit is cleared If BSy bit and BCy bit are set at the same time, BSy has the priority

12.6.8 Pport lock register (GPIOx_LOCK) (x=A...B)

This register protects the configuration of GPIO from being modified by mistake during the running of the program. If the GPIO configuration is modified again, it can be modified only after the system is reset. When configuring GPIO locking function, it is necessary to execute the specified sequence to the register to start the GPIO locking function.

Offset address: 0x1C

Reset value: 0x0000 0000

Field	Name	R/W	Description
15:0	LOCKy	R/W	PortxLock bit y Configure (y=0...15) 0: The configuration of Port x Pin y is not locked 1: The configuration of Port x Pin y is locked These bits can be read and written, but can only be written when LOCKKEY=0.
16	LOCKKEY	R/W	Lock key This bit determines whether the port configuration lock key bit is activated 0: Not activated 1: Activated; GPIOx_LOCK register is locked until the next MUC reset is generated. Lock key write sequence: Write LOCK[16]=1+LOCK[15:0] Write LOCK[16]=0+LOCK[15:0] Write LOCK[16]=1+LOCK[15:0] Read LOCK Read LOCK[16]=1 (this read operation can be selected to confirm whether to activate the lock key) Note: The value of LOCKy cannot be changed during the write sequence of the operation lock key. Any error in the write sequence of operation lock key will abort the lock. After the first lock sequence on any bit of the port, any read access on the LOCKKEY bit will return "1" until the next MCU is reset or the peripheral is reset.
31:17			Reserved

12.6.9 Port multiplexing function low 8-bit register (GPIOx_ALFL) (x=A...F)

Offset address: 0x20

Reset value: 0x0000 0000

Field	Name	R/W	Description
31:0	ALFSELY	R/W	<p>Port x Pin y Alternate Function Select (y=0...7)</p> <p>These bits can be read by software to configure the multiplexing function of the port.</p> <p>ALFSELY selection:</p> <p>0000: AF0</p> <p>0001: AF1</p> <p>0010: AF2</p> <p>0011: AF3</p> <p>0100: AF4</p> <p>0101: AF5</p> <p>0110: AF6</p> <p>0111: AF7</p> <p>1000: Reserved</p> <p>1001: Reserved</p> <p>1010: Reserved</p> <p>1011: Reserved</p> <p>1100: Reserved</p> <p>1101: Reserved</p> <p>1111: Reserved</p> <p>1110: Reserved</p>

12.6.10 Port multiplexing function high 8-bit register (GPIOx_ALFH) (x=A...F)

Offset address: 0x24

Reset value: 0x0000 0000

Field	Name	R/W	Description
31:0	ALFSELY	R/W	<p>Port x Pin y Alternate Function Select (y=8...15)</p> <p>These bits can be read by software to configure the multiplexing function of the port.</p> <p>ALFSELY selection:</p> <p>0000: AF0</p> <p>0001: AF1</p> <p>0010: AF2</p> <p>0011: AF3</p> <p>0100: AF4</p> <p>0101: AF5</p> <p>0110: AF6</p> <p>0111: AF7</p> <p>1000: Reserved</p> <p>1001: Reserved</p> <p>1010: Reserved</p> <p>1011: Reserved</p> <p>1100: Reserved</p> <p>1101: Reserved</p> <p>1111: Reserved</p> <p>1110: Reserved</p>

12.6.11 Port reset register (GPIOx_BR) (x=A...F)

Offset address: 0x28

Reset value: 0x0000 0000

Field	Name	R/W	Description
15:0	BRy	W	PortxPin y Reset Configure (y=0...15) These bits can only perform write operation, and the returned value is 0x0000 when reading these bits. These bits are used to affect the corresponding ODATAy 0: No effect 1: Corresponding ODATAy bit is cleared
31:16	Reserved		

13 Timer Overview

13.1 Full Name and Abbreviation Description of Terms

Table 42 Full Name and Abbreviation Description of Terms

Full name in English	English abbreviation
Timer	TMR
Update	U
Request	R
Event	EV
Capture	C
Compare	C
Length	LEN

13.2 Timer Category and Main Difference

In this series of products, there are three types of timers: advanced timer, general-purpose timer and basic timer (watchdog timer is described in other chapters).

The advanced timer includes the functions of general-purpose timer and basic timer. The advanced timer has four capture/compare channels, supports timing function, input capture and output compare function, breaking and complementary output function, and is a 16-bit timer that can count up/down.

The function of general-purpose timer is simpler than that of advanced timer. The main differences are the total number of channels, the number of complementary output channel groups and the breaking function.

The basic timer is a timer that can only realize timing function and has no external interface.

The main differences of timers included in the products are shown in the table below:

Table 43 Main Differences among Timers Included in the Products

Item	Specific content/Category	Advanced timer	General-purpose timer					Basic timer	
			TMR2	TMR3	TMR14	TMR15	TMR16/17	TMR6	TMR7
Name	—	TMR1	TMR2	TMR3	TMR14	TMR15	TMR16/17	TMR6	TMR7
Timebase unit	Counter	16 bits	32 bits	16 bits	16 bits	16 bits	16 bits	16 bits	
	Prescaler	16 bits	16 bits		16 bits	16 bits	16 bits	16 bits	
	Count mode	Up Down Center alignment	Up Down Center alignment	Up Down Center alignment	Up Down Center alignment	Up Down Center alignment	Up	Up	
Channel	Input channel	4	4	1	2	1	0		
	Capture/Compare channel	4	4	1	2	1	0		

Item	Specific content/Category	Advanced timer	General-purpose timer				Basic timer
	Output channel	7	4	1	2	1	0
	Complementary output channel	3 groups	0	0	1	1	0
Function	General DMA request	OK	OK	OK	OK	OK	OK
	PWM mode	Yes	Yes	None	Yes	None	None
	Single-pulse mode	Yes	Yes	None	Yes	Yes	None
	Forced output mode	Yes	Yes	Yes	Yes	Yes	None
	Dead-time insertion	Yes	None	None	Yes	Yes	None

Timer term

Table 44 Definitions and Terms of Pins

Name	Description
TMRx_ETR	External trigger signal of Timer x
TMRx_CH1、TMRx_CH2、TMRx_CH3、TMRx_CH4	Channel 1/2/3/4 of Timer x
TMRx_CHyN	Complementary output channel y of Timer x
TMRx_BKIN	Breaking signal of Timer x

Table 45 Definitions and Terms of Internal Signals

Name	Description
ETR	TMRx_ETR external trigger signal
ETRF	External trigger filter
ETRP	External trigger prescaler
-	-
ITR, ITR0, ITR1	Internal trigger
TRGI	Clock/Trigger/Slave mode controller trigger input
TIF_ED	Timer input filter edge detection
-	-
CK_PSC	Prescaler clock
CK_CNT	Counter clock
PSC	Prescaler
CNT	Counter
AUTORLD	Autoload register
-	-

Name	Description
TIx, TI1	Timer input
TIxF, TI1F	Timer input filter
TI1_ED	Timer input edge detection
TIxFPx, TI1FP1	Timer input filter polarity
ICx, IC1	Input capture
ICxPS, IC1PS	Input capture prescaler
TRC	Trigger capture
BRK	Breaking signal
-	
OCx, OC1	Timer output coparison channel
OCxREF, OC1REF	Output compare reference signal
-	
TGI	Trigger interrupt
BI	Breaking interrupt
CCxI, CC1I	Capture/Compare interrupt
UEV	Update event
UIFLG	Update interrupt flag

14 Basic Timer (TMR6/7)

14.1 Introduction

The basic timers TMR6/7 have an unsigned 16-bit counter, auto reload register, prescaler and trigger controller.

The basic timer provides time reference for general-purpose timer and provides clock for DAC. DMA request can be generated by configuration.

14.2 Main Characteristics

- (1) Counter: 16-bit counter, which can only count up
- (2) Prescaler: 16-bit programmable prescaler
- (3) Clock source: There is only internal clock
- (4) Provide clock for DAC

14.3 Structure Block Diagram

Figure 23 Basic Timer Structure Block Diagram

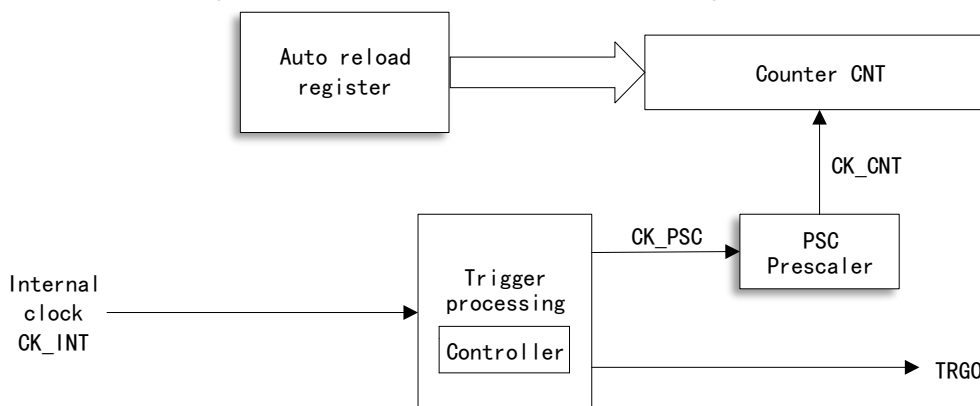

14.4 Functional Description

14.4.1 Clock Source Selection

The basic timer is driven by internal clock source TMRx_CLK

Configure the CNTEN bit of TMRx_CTRL1 register to enable the counter; when CNTEN bit is set, the internal clock CK_INT can generate CK_CNT to drive the counter through the controller and prescaler.

14.4.2 Timebase Unit

The time base unit in the basic timer contains three registers:

- Counter register (CNT) 16 bits
- Auto reload register (AUTORLD) 16 bits
- Prescaler register (PSC) 16 bits

Counter CNT

The basic timer only has one count mode: count-up

Count-up mode

When the counter is in count-up mode, the counter will count up from 0; every time a pulse is generated, the counter will increase by 1 and when the value of the counter (TMRx_CNT) is equal to the value of the auto reload (TMRx_AUTORLD), then the counter will start to count again from 0, a count-up overrun event will be generated, and the value of the auto reload (TMRx_AUTORLD) is written in advance.

Disable the update event and set UD bit of TMRx_CTRL1 register to 1.

Generate the update interrupt or DMA request and set URSSEL bit in TMRx_CTRL1 register.

When an update event occurs, both the auto reload register and the prescaler register will be updated.

Figure 24 Timer Timing Diagram, the internal clock division factor is 1 or 2

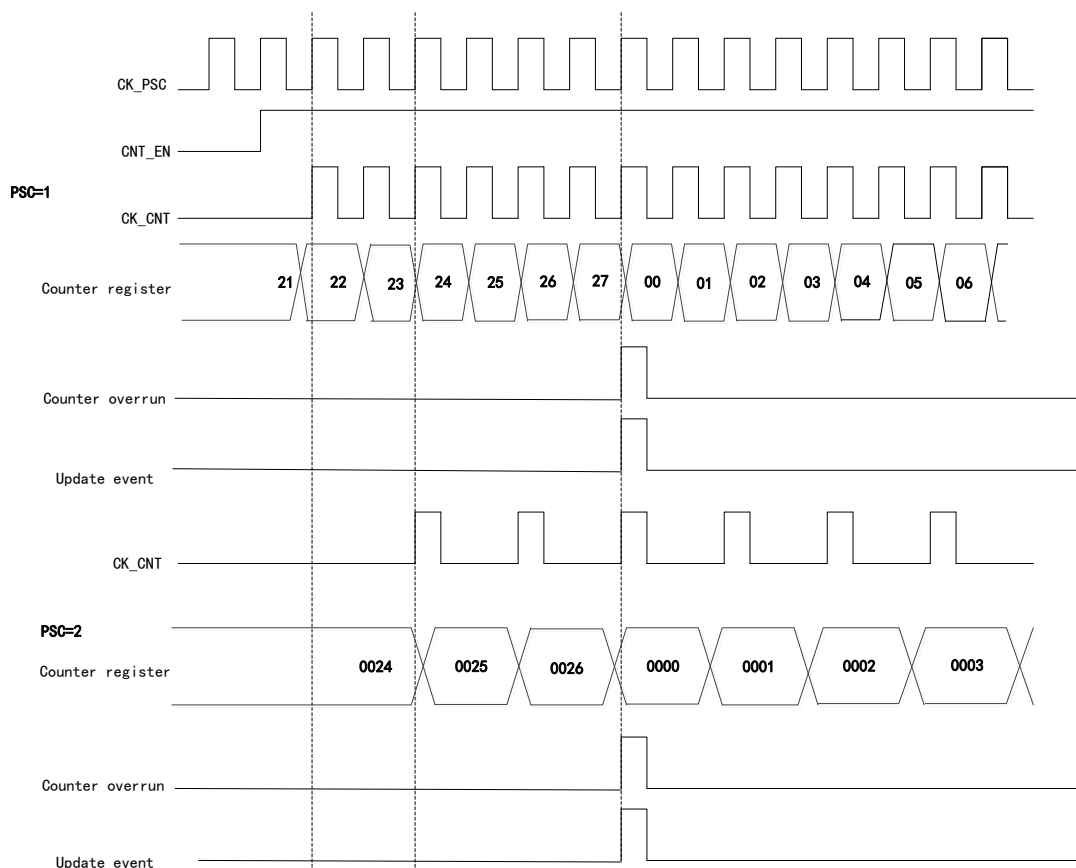

Prescaler PSC

The prescaler is 16 bits and programmable, and it can divide the clock frequency of the counter to any value between 1 and 65536 (controlled by TMRx_PSC register), and after frequency division, the clock will drive the counter CNT to

count. The prescaler has a buffer, which can be changed during running.

14.5 Register Address Mapping

In the following table, all registers of TMRx are mapped to a 16-bit addressable (address) space.

Table 46 TMR6 and TMR7 Register Address Mapping

Register name	Description	Offset address
TMRx_CTRL1	Control register 1	0x00
TMRx_CTRL2	Control register 2	0x04
TMRx_DIEN	DMA/Interrupt enable register	0x0C
TMRx_STS	State register	0x10
TMRx_CEG	Control event generation register	0x14
TMRx_CNT	Counter register	0x24
TMRx_PSC	Prescaler register	0x28
TMRx_AUTORLD	Auto reload register	0x2C

14.6 Register Functional Description

14.6.1 Control register 1 (TMRx_CTRL1)

Offset address: 0x00

Reset value: 0x0000

Field	Name	R/W	Description
0	CNTEN	R/W	Counter Enable 0: Disable 1: Enable When the timer is configured as external clock, gated mode and encoder mode, it is required to write 1 to the bit by software to start regular work; when it is configured as the trigger mode, it can be written to 1 by hardware.
1	UD	R/W	Update Disable Update event can cause AUTORLD, PSC and CCx to generate the value of update setting. 0: Update event is allowed (UEV) An update event can occur in any of the following situations: The counter overruns/underruns; Set UEG bit; Update generated by slave mode controller. 1: Update event is disabled
2	URSEL	R/W	Update Request Source Select If interrupt or DMA is enabled, the update event can generate update interrupt or DMA request. Different update request sources can be selected through this bit. 0: The counter overruns or underruns Set UEG bit Update generated by slave mode controller 1: The counter overruns or underruns

Field	Name	R/W	Description
3	SPMEN	R/W	Single Pulse Mode Enable When an update event is generated, the output level of the channel can be changed; in this mode, the CNTEN bit will be cleared, the counter will be stopped, and the output level of the channel will not be changed. 0: Disable 1: Enable
6:4	Reserved		
7	ARPEN	R/W	TMRx_AUTORLD Register Auto-reload Preload Enable When the buffer is disabled, the program modification TMRx_AUTORLD will immediately modify the values loaded to the counter; when the buffer is enabled, the program modification TMRx_AUTORLD will modify the values loaded to the counter in the next update event. 0: Disable 1: Enable
15:8	Reserved		

14.6.2 Control register 2 (TMRx_CTRL2)

Offset address: 0x04

Reset value: 0x0000

Field	Name	R/W	Description
3:0	Reserved		
6:4	MMSEL	R/W	Master Mode Signal Select The signals of timers working in master mode can be used for TRGO, which affects the work of timers in slave mode and cascaded with master timer, and specifically affects the configuration of timers in slave mode. 000: Reset; the reset signal of master mode timer is used for TRGO 001: Enable; the counter enable signal of master mode timer is used for TRGO 010: Update; the update event of master mode timer is used for TRGO Others: Reserved
15:7	Reserved		

14.6.3 DMA/Interrupt enable register (TMRx_DIEN)

Offset address: 0x0C

Reset value: 0x0000

Field	Name	R/W	Description
0	UIEN	R/W	Update interrupt Enable 0: Disable 1: Enable
7:1	Reserved		
8	UDIEN	R/W	Update DMA Request Enable 0: Disable 1: Enable
15:9	Reserved		

14.6.4 State register (TMRx_STS)

Offset address: 0x10

Reset value: 0x0000

Field	Name	R/W	Description
0	UIFLG	RC_W0	Update Event Interrupt Generate Flag 0: Update event interrupt does not occur 1: Update event interrupt occurs When the counter value is reloaded or reinitialized, an update event will be generated. The bit is set to 1 by hardware and cleared by software; update events are generated in the following situations: (1) UD=0 on TMRx_CTRL1 register, and when the value of the repeat counter overruns/underruns, an update event will be generated; (2) URSSEL=0 and UD=0 on TMRx_CTRL1 register, configure UEG=1 on TMRx_CEG register to generate update event, and the counter needs to be initialized by software; (3) URSSEL=0 and UD=0 on TMRx_CTRL1 register, generate update event when the counter is initialized by trigger event.
15:1	Reserved		

14.6.5 Control event generation register (TMRx_CEG)

Offset address: 0x14

Reset value: 0x0000

Field	Name	R/W	Description
0	UEG	W	Update Event Generate 0: Invalid 1: Initialize the counter and generate the update event This bit is set to 1 by software, and cleared by hardware. Note: When an update event is generated, the counter of the prescaler will be cleared, but the prescaler factor remains unchanged. In the count-down mode, the counter reads the value of TMRx_AUTORLD; in center alignment mode or count-up mode, the counter will be cleared.
15:1	Reserved		

Note: The state of external I/O pin connected to the standard OCx channel depends on the state of the OCx channel and the GPIO and AFIO registers.

14.6.6 Counter register (TMRx_CNT)

Offset address: 0x24

Reset value: 0x0000

Field	Name	R/W	Description
15:0	CNT	R/W	Counter Value

14.6.7 Prescaler register (TMRx_PSC)

Offset address: 0x28

Reset value: 0x0000

Field	Name	R/W	Description
15:0	PSC	R/W	Prescaler Value Clock frequency of counter (CK_CNT) = $f_{CK_PSC} / (PSC + 1)$

14.6.8 Auto reload register (TMRx_AUTORLD)

Offset address: 0x2C

Reset value: 0xFFFF

Field	Name	R/W	Description
-------	------	-----	-------------

Field	Name	R/W	Description
15:0	AUTORLD	R/W	Auto Reload Value When the value of auto reload is empty, the counter will not count.

15 General-purpose Timer (TMR2/3)

15.1 Introduction

The general-purpose timer takes the time base unit as the core, and has the functions of input capture and output compare, and can be used to measure the pulse width, frequency and duty cycle, and generate the output waveform. Include a 16-bit or 32-bit auto reload counter (realize up, down and center alignment counting).

The timer and timer are independent of each other, and they can achieve synchronization and cascading.

15.2 Main Characteristics

- (1) Timebase unit
 - Counter: 16-bit (TMR3) or 32-bit (TMR2) counter, which can realize up, down and center alignment counting
 - Prescaler register: 16-bit programmable prescaler
 - Auto reloading function
- (2) Clock source selection
 - Internal clock
 - External input
 - External trigger
 - Internal trigger
- (3) Input function
 - Counting function
 - PWM input
 - Encoder interface mode
- (4) Output function
 - PWM output mode
 - Forced output mode
 - Single-pulse mode
- (5) Master/Slave mode controller of timer
 - Timers can be synchronized and cascaded
 - Support multiple slave modes and synchronization signals
- (6) Interrupt and DMA request event
 - Update event (counter overrun/underrun, counter initialization)
 - Trigger event (counter start, stop, internal/external trigger)
 - Input capture
 - Output compare

15.3 Structure Block Diagram

Figure 25 General-purpose Timer TMR2/3 Structure Block Diagram

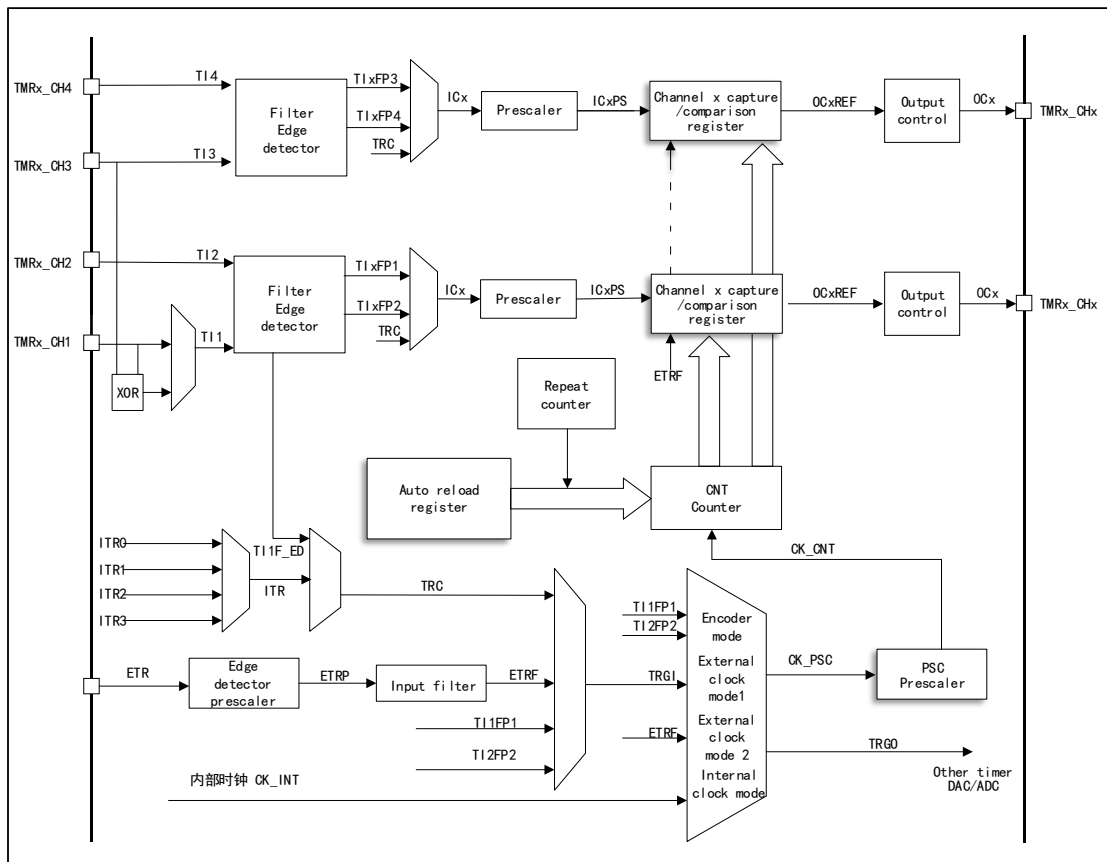

15.4 Functional Description

15.4.1 Clock Source Selection

The general-purpose timer has four clock sources

Internal clock

It is TMRx_CLK from RCM, namely the driving clock of the timer; when the slave mode controller is disabled, the clock source CK_PSC of the prescaler is driven by the internal clock CK_INT.

External clock mode 1

The trigger signal generated from the input channel TI1/2/3/4 of the timer after polarity selection and filtering is connected to the slave mode controller to control the work of the counter. Besides, the pulse signal generated by the input of Channel 1 after double-edge detection of the rising edge and the falling edge is logically equal or the future signal is T11F_ED signal, namely double-edge signal of TIF_ED. Specially the PWM input can only be input by TI1/2.

External clock mode 2

After polarity selection, frequency division and filtering, the signal from external

trigger interface (ETR) is connected to slave mode controller through trigger input selector to control the work of counter.

Internal trigger input

The timer is set to work in slave mode, and the clock source is the output signal of other timers. At this time, the clock source has no filtering, and the synchronization or cascading between timers can be realized. The master mode timer can reset, start, stop or provide clock for the slave mode timer.

15.4.2 Timebase Unit

The time base unit in the general-purpose timer contains three registers

- Counter register (CNT) 16/32 bits
- Auto reload register (AUTORLD) 16/32 bits
- Prescaler (PSC) 16/32 bits

Counter CNT

There are three counting modes for the counter in the general-purpose timer

- Count-up mode
- Count-down mode
- Center alignment mode

Count-up mode

Set to the count-up mode by CNTDIR bit of configuration control register (TMRx_CTRL1).

When the counter is in count-up mode, the counter will count up from 0; every time a pulse is generated, the counter will increase by 1 and when the value of the counter (TMRx_CNT) is equal to the value of the auto reload (TMRx_AUTORLD), the counter will start to count again from 0, a count-up overrun event will be generated, and the value of the auto reload (TMRx_AUTORLD) is written in advance.

When the counter overruns, an update event will be generated. At this time, the auto reload shadow register and the prescaler buffer will be updated. The update event can be disabled by UD bit of configuration control register TMRx_CTRL1.

Figure 26 Timing Diagram when Division Factor is 1 or 2 in Count-up Mode

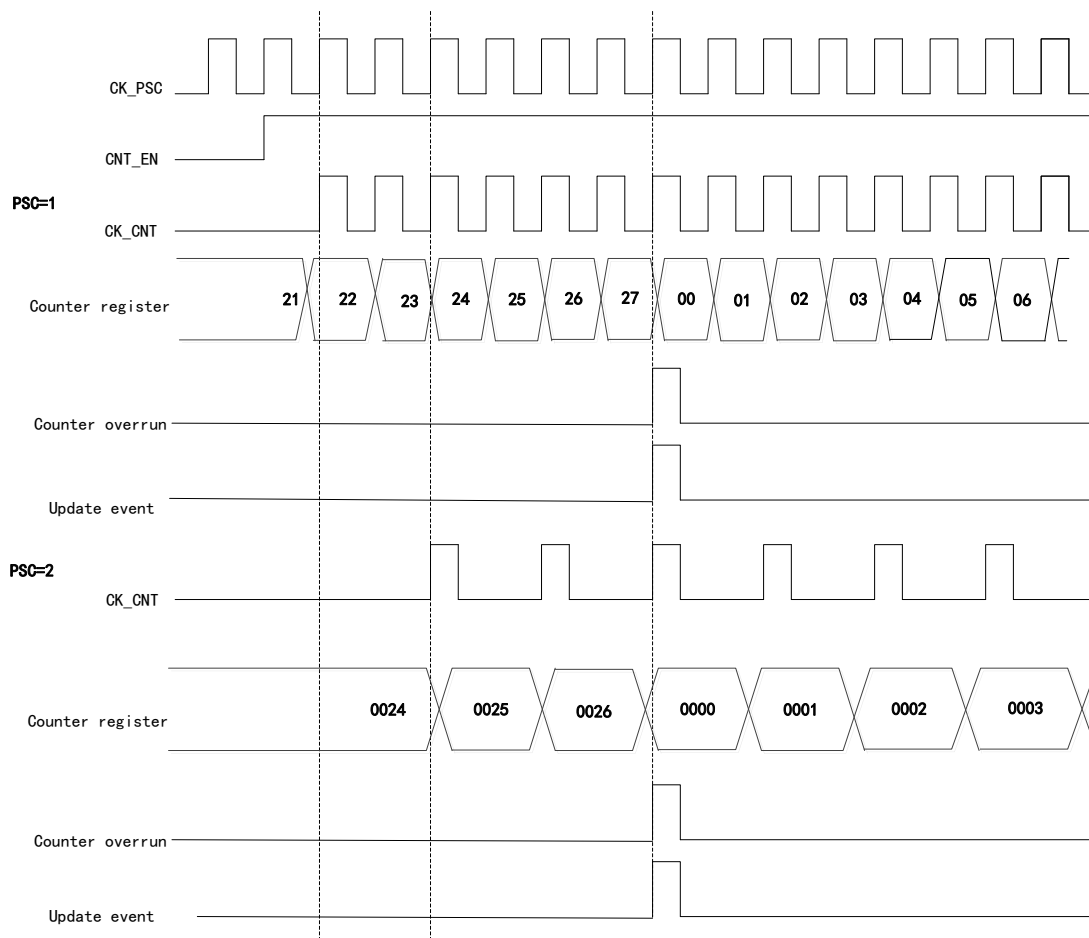

Count-down mode

Set to the count-down mode by CNTDIR bit of configuration control register (TMRx_CTRL1).

When the counter is in count-down mode, the counter will start to count down from the value of the auto reload (TMRx_AUTORLD); every time a pulse is generated, the counter will decrease by 1 and when it becomes 0, the counter will start to count again from (TMRx_AUTORLD), meanwhile, a count-down overrun event will be generated, and the value of the auto reload (TMRx_AUTORLD) is written in advance.

When the counter overruns, an update event will be generated. At this time, the auto reload shadow register and the prescaler buffer will be updated. The update event can be disabled by configuring the UD bit of the TMRx_CTRL1 register.

Figure 27 Timing Diagram when Division Factor is 1 or 2 in Count-down Mode

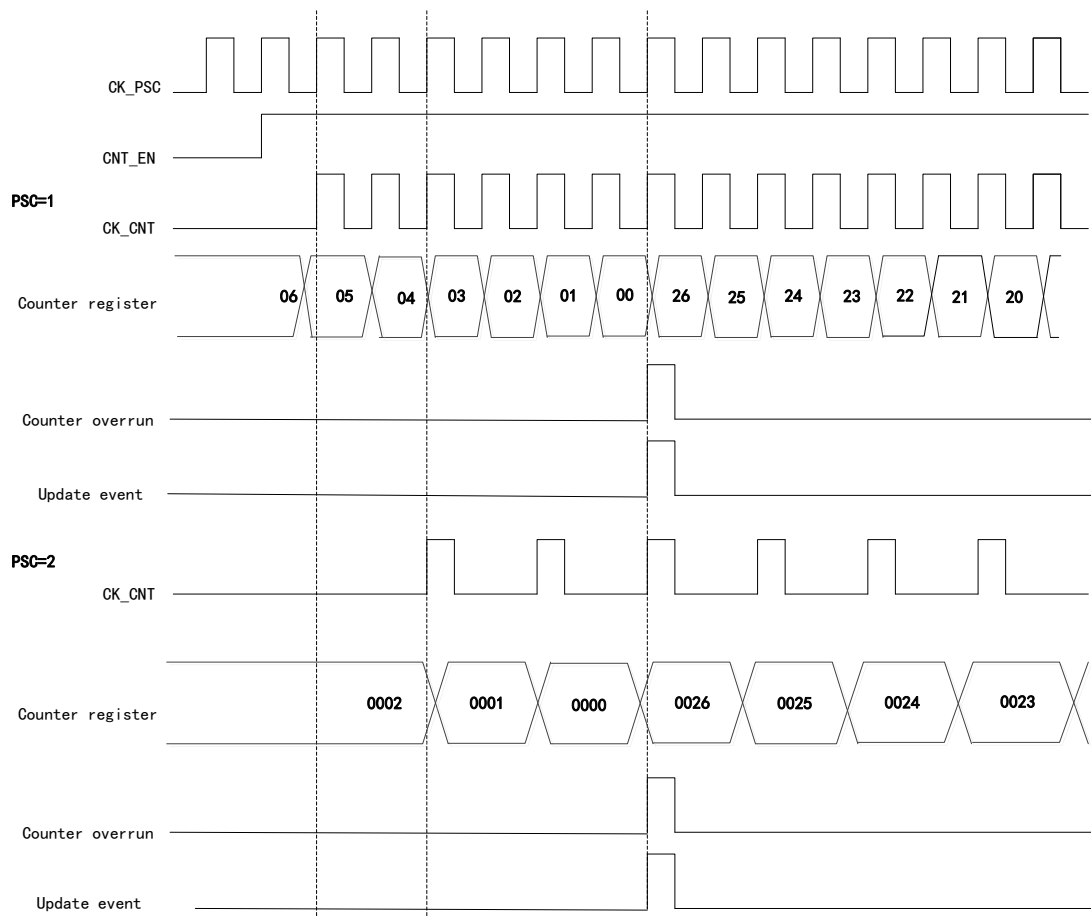

Center alignment mode

Set to the center alignment mode by CNTDIR bit of configuration control register (TMRx_CTRL1).

When the counter is in center alignment mode, the counter counts up from 0 to the value of auto reload (TMRx_AUTORLD), then counts down to 0 from the value of the auto reload (TMRx_AUTORLD), which will repeat; in counting up, when the counter value is (AUTORLD-1), a counter overrun event will be generated; in counting down, when the counter value is 1, a counter underrun event will be generated.

Figure 28 Timing Diagram when Division Factor is 1 or 2 in Center Alignment Mode

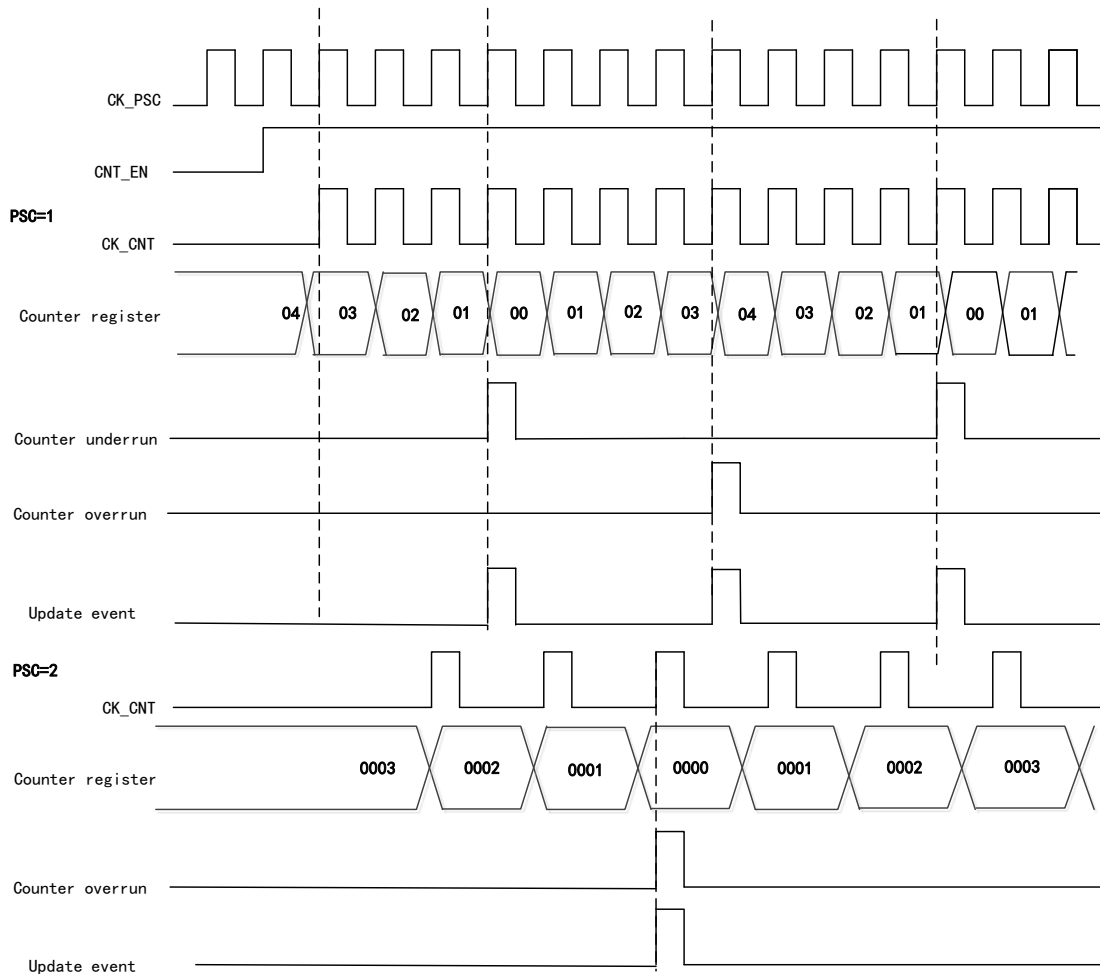

Prescaler PSC

The prescaler is 16 bits and programmable, and it can divide the clock frequency of the counter to any value between 1 and 65536 (controlled by TMRx_PSC register), and after frequency division, the clock will drive the counter CNT to count. The prescaler has a buffer, which can be changed during running.

15.4.3 Input Capture

Input capture channel

The general-purpose timer has four independent capture/compare channels, each of which is surrounded by a capture/compare register.

In the input capture, the measured signal will enter from the external pin T1/2/3/4 of the timer, first pass through the edge detector and input filter, and then into the capture channel. Each capture channel has a corresponding capture register. When the capture occurs, the value of the counter CNT will be latched in the capture register CCx. Before entering the capture register, the signal will pass

through the prescaler, which is used to set how many events to capture at a time.

Input capture application

Input capture is used to capture external events, and can give the time flag to indicate the occurrence time of the event and measure the pulse jump edge events (measure the frequency or pulse width), for example, if the selected edge appears on the input pin, the TMRx_CCx register will capture the current value of the counter and the CCxIFLG bit of the state register TMRx_STS will be set to 1; if CCxIEN=1, an interrupt will be generated.

In capture mode, the timing, frequency, period and duty cycle of a waveform can be measured. In the input capture mode, the edge selection is set to rising edge detection. When the rising edge appears on the capture channel, the first capture occurs, at this time, the value of the counter CNT will be latched in the capture register CCx; at the same time, it will enter the capture interrupt, a capture will be recorded in the interrupt service program and the value will be recorded. When the next rising edge is detected, the second capture occurs, the value of counter CNT will be latched in capture register CCx again, at this time, it will enter the capture interrupt again, the value of capture register will be read, and the cycle of this pulse signal will be obtained through capture.

15.4.4 Output Compare

There are eight modes of output compare: freeze, channel x is valid level when matching, channel x is invalid level when matching, flip, force is invalid, force is valid, PWM mode 1 and PWM mode 2, which are configured by OCxMOD bit in TMRx_CCMx register and can control the waveform of output signal in output compare mode.

Output compare application

In the output compare mode, the position, polarity, frequency and time of the pulse generated by the timer can be controlled.

When the value of the counter is equal to that of the capture/compare register, the channel output can be set as high level, low level or flip by configuring the OCxMOD bit in TMRx_CCMx register and the CCxPOL bit in the output polarity TMRx_CCEN register.

When CCxIFLG=1 in TMRx_STS register, if CCxIEN=1 in TMRx_DIEN register, an interrupt will be generated; if CCDSEL=1 in TMRx_CTRL2 register, DMA request will be generated.

15.4.5 PWM Output Mode

PWM mode is an adjustable pulse signal output by the timer. The pulse width of the signal is determined by the value of the compare register CCx, and the cycle is determined by the value of the auto reload AUTORLD.

PWM output mode contains PWM mode 1 and PWM mode 2; PWM mode 1 and PWM mode 2 are divided into count-up, count-down and edge alignment counting; in PWM mode 1, if the value of the counter CNT is less than the value of the compare register CCx, the output level will be valid; otherwise, it will be invalid.

Set the timing diagram in PWM mode 1 when CCx=5, AUTORLD=7

Figure 29 PWM1 Count-up Mode Timing Diagram

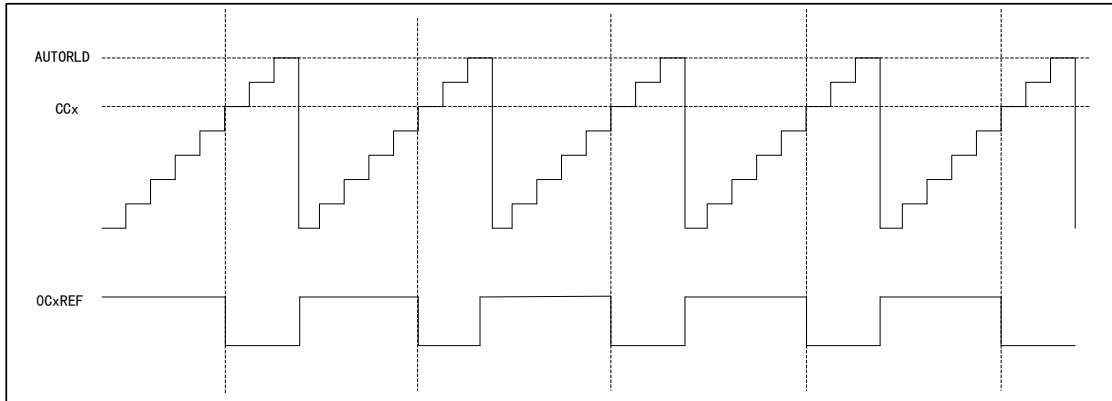

Figure 30 PWM1 Count-down Mode Timing Diagram

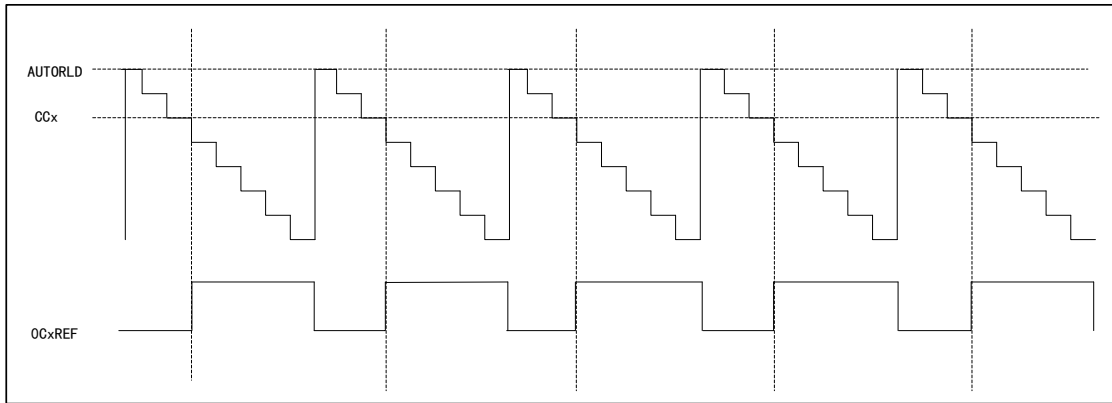
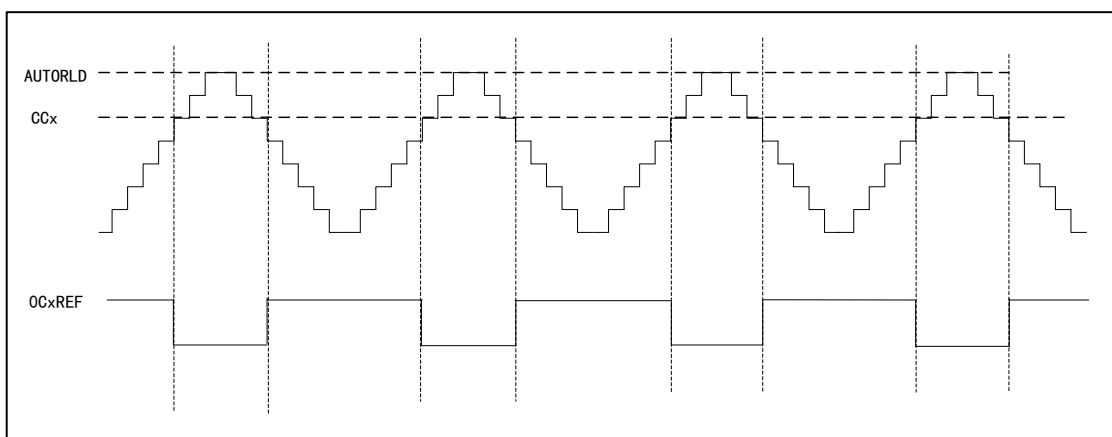

Figure 31 PWM1 Center Alignment Mode Timing Diagram



In PWM mode 2, if the value of the counter CNT is less than that of the compare register CCx, the output level will be invalid; otherwise, it will be valid.

Set the timing diagram in PWM mode 2 when CCx=5, AUTORLD=7

Figure 32 PWM2 Count-up Mode Timing Diagram

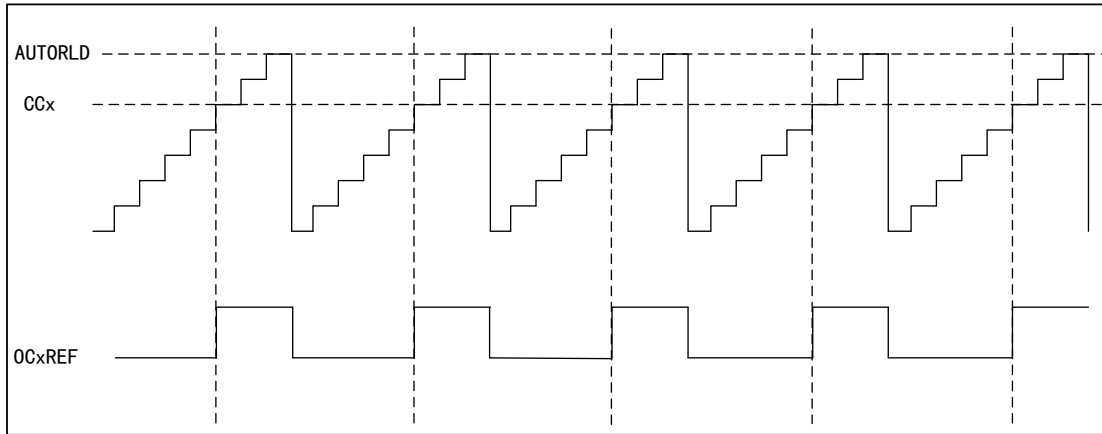

Figure 33 PWM2 Count-down Mode Timing Diagram

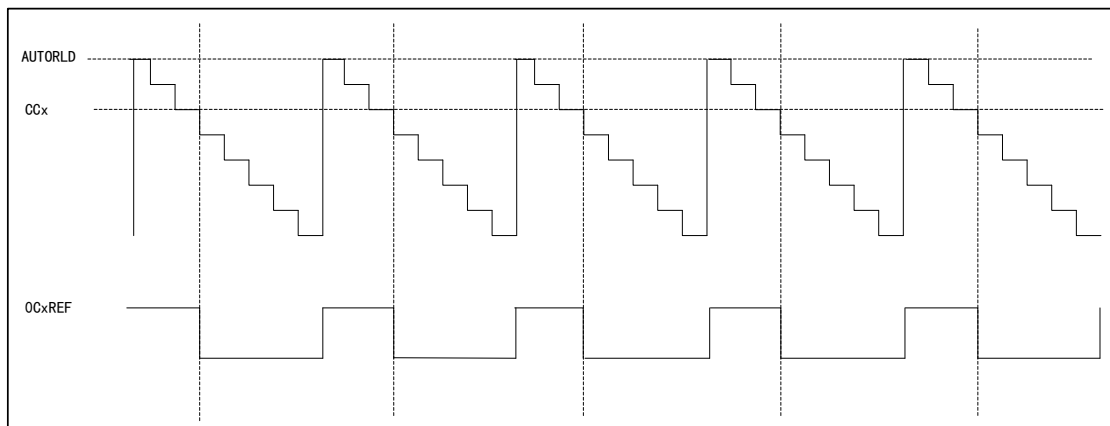
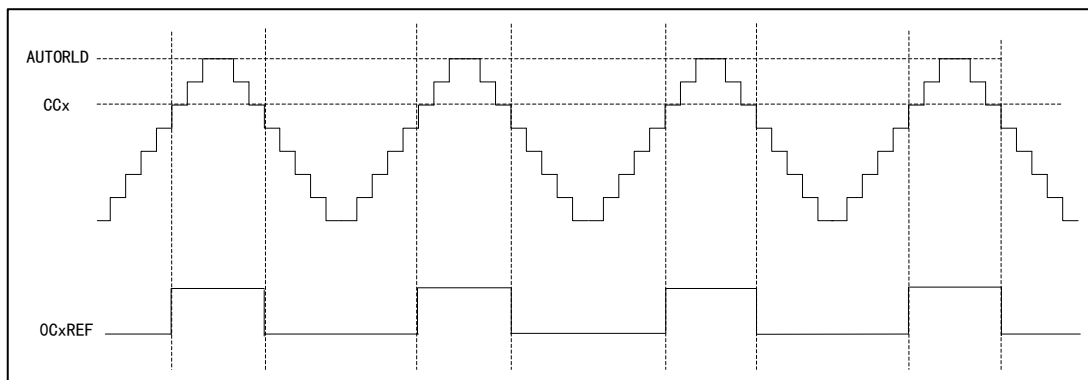

Figure 34 PWM2 Center Alignment Mode Timing Diagram



15.4.6 PWM Input Mode

PWM input mode is a particular case of input capture.

In PWM input mode, as only TI1FP1 and TI1FP2 are connected to the slave mode controller, input can be performed only through the channels TMRx_CH1 and TMRx_CH2, which need to occupy the capture registers of CH1 and CH2.

In the PWM input mode, the PWM signal enters from TMRx_CH1, and the signal will be divided into two channels, one can measure the cycle and the other can measure the duty cycle. In the configuration, it is only required to set the polarity of one channel, and the other will be automatically configured with the opposite polarity.

In this mode, the slave mode controller should be configured as the reset mode (SMFSEL bit of TMRx_SMCTRL register)

Figure 35 Timing Diagram in PWM Input Mode

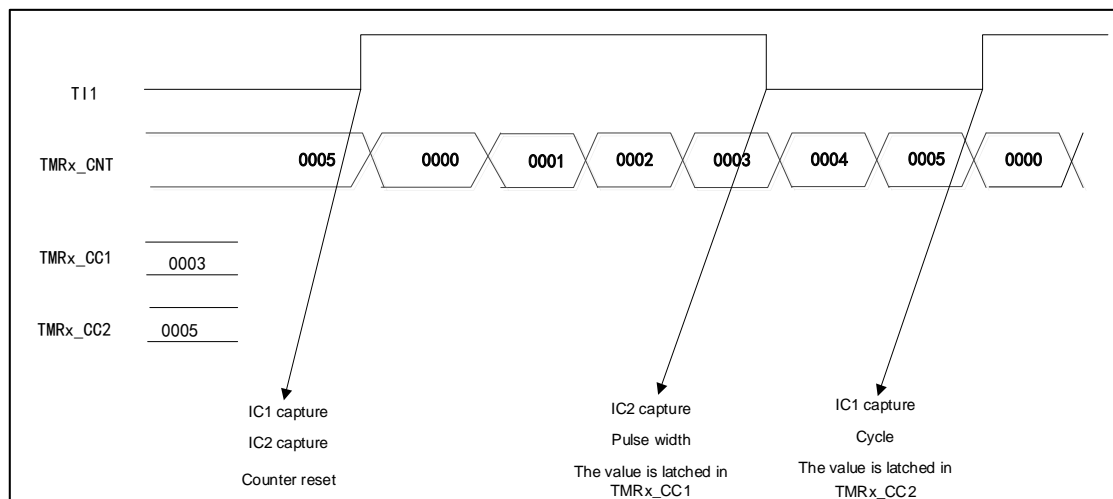

15.4.7 Single-pulse Mode

The single-pulse mode is a special case of timer compare output, and is also a special case of PWM output mode.

Set SPMEN bit of TMRx_CTRL1 register, and select the single-pulse mode. After the counter is started, a certain number of pulses will be output before the update event occurs. When an update event occurs, the counter will stop counting, and the subsequent PWM waveform output will no longer be changed.

After a certain controllable delay, a pulse with controllable pulse width is generated in single-pulse mode through the program. The delay time is defined by the value of TMRx_CCx register; in the count-up mode, the delay time is CCx and the pulse width is AUTORLD-CCx; in the count-down mode, the delay time is AUTORLD-CCx and the pulse width is CCx.

Figure 36 Timing Diagram in Single-pulse Mode

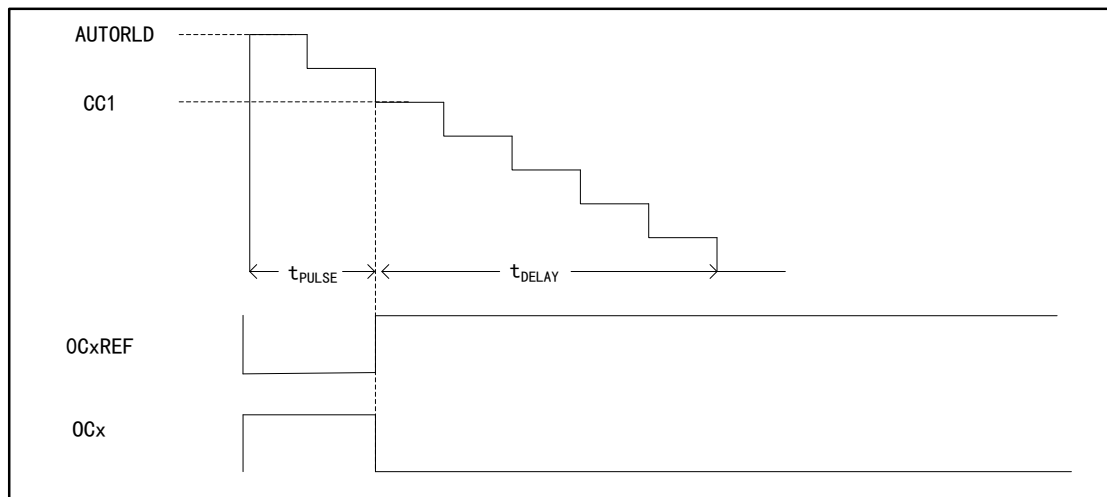

15.4.8 Forced Output Mode

In the forced output mode, the compare result is ignored, and the corresponding level is directly output according to the configuration instruction.

- CCxSEL=00 for TMRx_CCMx register, set CCx channel as output
- OCxMOD=100/101 for TMRx_CCMx register, set to force OCxREF signal to invalid/valid state

In this mode, the corresponding interrupt and DMA request will still be generated.

15.4.9 Encoder Interface Mode

The encoder interface mode is equivalent to an external clock with direction selection. In the encoder interface mode, the content of the timer can always indicate the position of the encoder.

The selection methods of encoder interface is as follows:

- By setting SMFSEL bit of TMRx_SMCTRL register, set the counter to count on the edge of TI1 channel /TI2 channel, or count on the edge of TI1 and TI2 at the same time.
- Select the polarity of TI1 and TI2 by setting the CC1POL and CC2POL bits of TMRx_CCEN register.
- Select to filter or not by setting the IC1F and IC2F bits of TMRx_CCM1 register.

The two input TI1 and TI2 can be used as the interface of incremental encoder. The counter is driven by the effective jump of the signals TI1FP1 and TI2FP2 after filtering and edge selection in TI1 and TI2.

The count pulse and direction signal are generated according to the input signals of TI1 and TI2

- The counter will count up/down according to the jumping sequence of the input signal
- Set CNTDIR of control register TMRx_CTRL1 to be read-only (CNTDIR will be re-calculated due to jumping of any input end)

The change mechanism of counter count direction is shown in the figure below

Table 47 Relationship between Count Direction and Encoder

Effective edge		Count only in T11		Count only in T12		Count in both T11 and T12	
Level of relative signal		High	Low	High	Low	High	Low
T11FP1	Rising edge	—		Count down	Count up	Count down	Count up
	Falling edge			Count up	Count down	Count up	Count down
T12FP2	Rising edge	Count up	Count down	—		Count up	Count down
	Falling edge	Count down	Count up			Count down	Count up

The external incremental encoder can be directly connected with MCU, not needing external interface logic, so the comparator is used to convert the differential output of the encoder to digital signal to increase the immunity from noise interference.

Among the following examples,

- IC1FP1 is mapped to T11
- IC2FP2 is mapped to T12
- Neither IC1FP1 nor IC2FP2 is reverse phase
- The input signal is valid at the rising edge and falling edge
- Enable the counter

Figure 37 Counter Operation Example in Encoder Mode

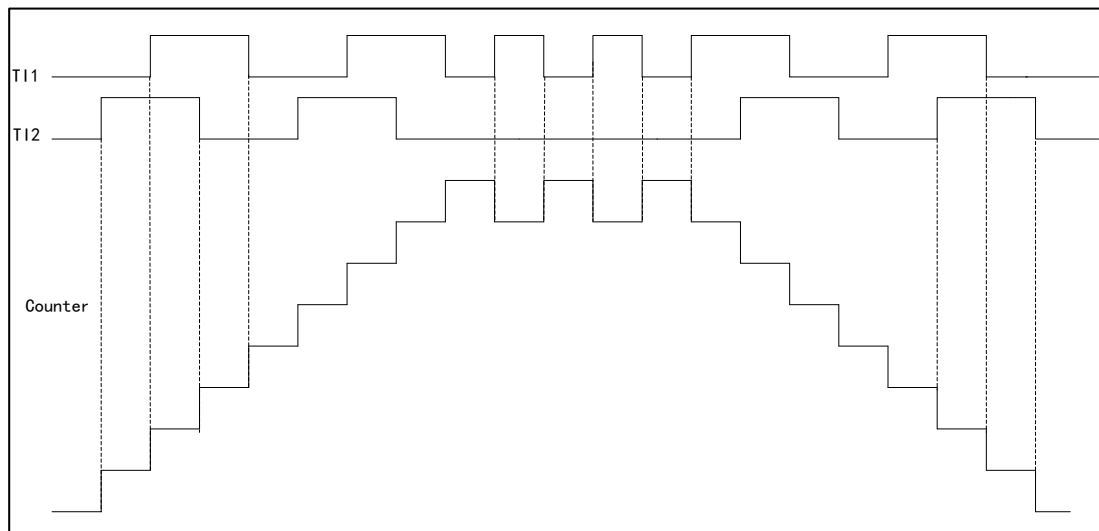

For example, when T11 is at low level, and T12 is in rising edge state, the counter will count up.

Figure 38 Example of Encoder Interface Mode of IC1FP1 Reversed Phase

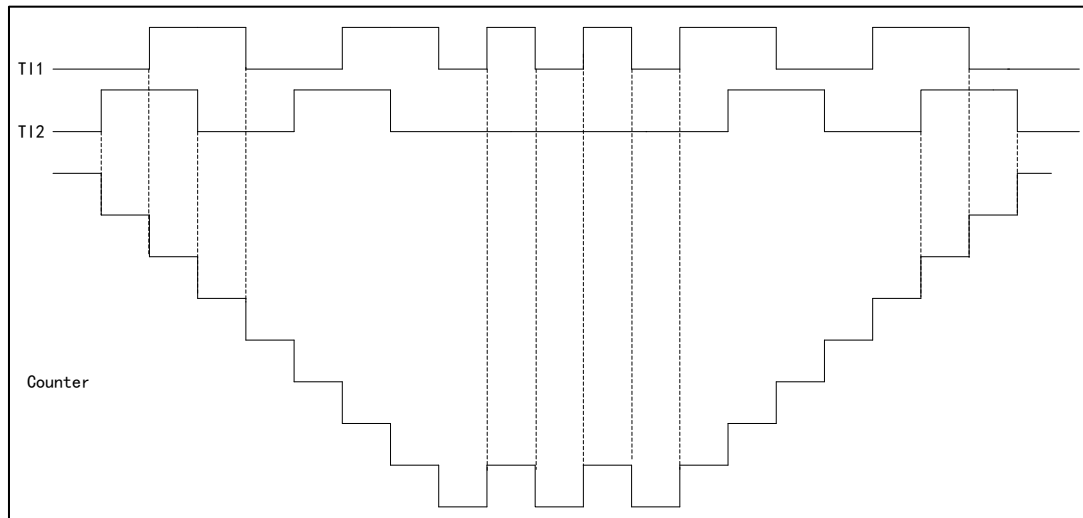

For example, when T11 is at low level, and the rising edge of T12 jumps, the counter will count down.

15.4.10 Slave Mode

TMRx timer can synchronize external trigger

- Reset mode
- Gated mode
- Trigger mode

SMFSEL bit in TMRx_SMCTRL register can be set to select the mode

SMFSEL=100 set the reset mode, SMFSEL=101 set the gated mode, SMFSEL=110 set the trigger mode.

In the reset mode, when a trigger input event occurs, the counter and prescaler will be initialized, and the rising edge of the selected trigger input (TRGI) will reinitialize the counter and generate a signal to update the register.

In the gated mode, the enable of the counter depends on the high level of the selected input. When the trigger input is high, the clock of the counter will be started. Once the trigger input becomes low, the counter will stop (but not be reset). The start and stop of the counter are controlled.

In the trigger mode, the enable of the counter depends on the event on the selected input, the counter is started (but is not reset) at the rising edge of the trigger input, and only the start of the counter is controlled.

15.4.11 Timer Interconnection

See 18.4.14 for details.

15.4.12 Interrupt and DMA Request

The timer can generate an interrupt when an event occurs during operation

- Update event (counter overrun/underrun, counter initialization)
- Trigger event (counter start, stop, internal/external trigger)
- Capture/Compare event

Some internal interrupt events can generate DMA requests, and special interfaces can enable or disable DMA requests.

15.4.13 Clear OCxREF Signal when External Events Occur

This function is used for output compare and PWM mode.

In one channel, the high level of ETRF input port will reduce the signal of OCxREF to low level, and the OCxCEN bit in capture/compare register TMRx_CCMx is set to 1, and OCxREF signal will remain low until the next update event.

Set TMRx to PWM mode, close the external trigger prescaler, and disable the external trigger mode 2; when ETRF input is high, set OCxCEN=0, and the output OCxREF signal is shown in the figure below.

Figure 39 OCxREF Timing Diagram

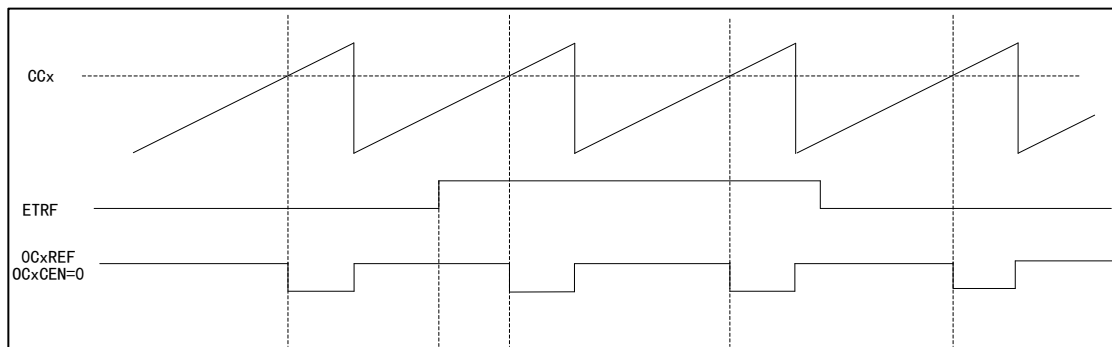

Set TMRx to PWM mode, close the external trigger prescaler, and disable the external trigger mode 2; when ETRF input is high, set OCxCEN=1, and the output OCxREF signal is shown in the figure below.

Figure 40 OCxREF Timing Diagram

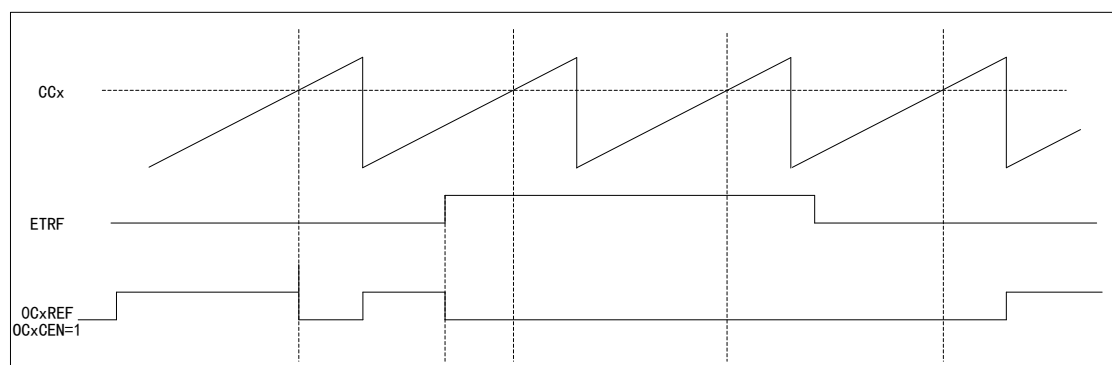

15.5 Register Address Mapping

In the following table, all registers of TMR2 and TMR3 are mapped to a 16-bit

addressable (address) space.

Table 48 TMR2 and TMR3 Register Address Mapping

Register name	Description	Offset address
TMRx_CTRL1	Control register 1	0x00
TMRx_CTRL2	Control register 2	0x04
TMRx_SMCTRL	Slave mode control register	0x08
TMRx_DIEN	DMA/Interrupt enable register	0x0C
TMRx_STS	State register	0x10
TMRx_CEG	Control event generation register	0x14
TMRx_CCM1	Capture/Compare mode register 1	0x18
TMRx_CCM2	Capture/Compare mode register 2	0x1C
TMRx_CCEN	Capture/Compare enable register	0x20
TMRx_CNT	Counter register	0x24
TMRx_PSC	Prescaler register	0x28
TMRx_AUTORLD	Auto reload register	0x2C
TMRx_CC1	Channel 1 capture/compare register	0x34
TMRx_CC2	Channel 2 capture/compare register	0x38
TMRx_CC3	Channel 3 capture/compare register	0x3C
TMRx_CC4	Channel 4 capture/compare register	0x40
TMRx_DCTRL	DMA control register	0x48
TMRx_DMADDR	DMA address register of continuous mode	0x4C

15.6 Register Functional Description

15.6.1 Control register 1 (TMRx_CTRL1)

Offset address: 0x00

Reset value: 0x0000

Field	Name	R/W	Description
0	CNTEN	R/W	Counter Enable 0: Disable 1: Enable When the timer is configured as external clock, gated mode and encoder mode, it is required to write 1 to the bit by software to start regular work; when it is configured as the trigger mode, it can be written to 1 by hardware.
1	UD	R/W	Update Disable Update event can cause AUTORLD, PSC and CCx to generate the value of update setting. 0: Update event is allowed (UEV) An update event can occur in any of the following situations: The counter overruns/underruns; Set UEG bit; Update generated by slave mode controller. 1: Update event is disabled

Field	Name	R/W	Description
2	URSEL	R/W	Update Request Source Select If interrupt or DMA is enabled, the update event can generate update interrupt or DMA request. Different update request sources can be selected through this bit. 0: The counter overruns or underruns Set UEG bit Update generated by slave mode controller 1: The counter overruns or underruns
3	SPMEN	R/W	Single Pulse Mode Enable When an update event is generated, the output level of the channel can be changed; in this mode, the CNTEN bit will be cleared, the counter will be stopped, and the output level of the channel will not be changed. 0: Disable 1: Enable
4	CNTDIR	R/W	Counter Direction When the counter is configured in central alignment mode or encoder mode, the bit is read-only. 0: Count up 1: Count down
6:5	CAMSEL	R/W	Center Aligned Mode Select In the center alignment mode, the counter counts up and down alternately; otherwise, it will only count up or down. Different center alignment modes affect the timing of setting the output compare interrupt flag bit of the output channel to 1; when the counter is disabled (CNTEN=0), select the center alignment mode. 00: Edge alignment mode 01: Center alignment mode 1 (the output compare interrupt flag bit of output channel is set to 1 when counting down) 10: Center alignment mode 2 (the output compare interrupt flag bit of output channel is set to 1 when counting up) 11: Center alignment mode 3 (the output compare interrupt flag bit of output channel is set to 1 when counting up/down)
7	ARPEN	R/W	TMRx_AUTORLD Register Auto-reload Preload Enable When the buffer is disabled, the program modification TMRx_AUTORLD will immediately modify the values loaded to the counter; when the buffer is enabled, the program modification TMRx_AUTORLD will modify the values loaded to the counter in the next update event. 0: Disable 1: Enable
9:8	CLKDIV	R/W	Clock Divide Factor For the configuration of dead time and digital filter, CK_INT provides the clock, and the dead time and the clock of the digital filter can be adjusted by setting this bit. 00: $t_{DTS}=t_{CK_INT}$ 01: $t_{DTS}=2 \times t_{CK_INT}$ 10: $t_{DTS}=4 \times t_{CK_INT}$ 11: Reserved
15:10	Reserved		

15.6.2 Control register 2 (TMRx_CTRL2)

Offset address: 0x04

Reset value: 0x0000

Field	Name	R/W	Description
2:0	Reserved		
3	CCDSEL	R/W	Capture/compare DMA Select 0: Transmit DMA request of CCx when CCx event occurs 1: Transmit DMA request of CCx when an update event occurs

Field	Name	R/W	Description
6:4	MMSEL	R/W	Select the signal for TRGO in master mode of timer (Master Mode Signal Select) The signals of timers working in master mode can be used for TRGO, which affects the work of timers in slave mode and cascaded with master timer, and specifically affects the configuration of timers in slave mode. 000: Reset; the reset signal of master mode timer is used for TRGO 001: Enable; the counter enable signal of master mode timer is used for TRGO 010: Update; the update event of master mode timer is used for TRGO 011: Compare pulses; when the master mode timer captures/compares successfully (CCxIFLG=1), a pulse signal is output for TRGO 100: Compare mode 1; OC1REF is used to trigger TRGO 101: Compare mode 2; OC2REF is used to trigger TRGO 110: Compare mode 3; OC3REF is used to trigger TRGO 111: Compare mode 4; OC4REF is used to trigger TRGO
7	TI1SEL	R/W	Timer Input 1 Select 0: TMRx_CH1 pin is connected to TI1 input 1: TMRx_CH1, TMRx_CH2 and TMRx_CH3 pins are connected to TI1 input after exclusive
15:8	Reserved		

15.6.3 Slave mode control register (TMRx_SMCTRL)

Offset address: 0x08

Reset value: 0x0000

Field	Name	R/W	Description
2:0	SMFSEL	R/W	Select the slave mode function (Slave Mode Function Select) 000: Disable the slave mode, the timer can be used as master mode timer to affect the work of slave mode timer; if CTRL1_CNTEN=1, the prescaler is directly driven by the internal clock. 001: Encoder mode 1; according to the level of TI1FP1, the counter counts at the edge of TI2FP2. 010: Encoder mode 2; according to the level of TI2FP2, the counter counts at the edge of TI1FP1. 011: Encoder mode 3; according to the input level of another signal, the counter counts at the edge of TI1FP1 and TI2FP2. 100: Reset mode; the slave mode timer resets the counter after receiving the rising edge signal of TRGI and generates the signal to update the register. 101: Gated mode; the slave mode timer starts the counter to work after receiving the TRGI high level signal; it stops the counter when receiving TRGI low level; when receiving TRGI high level signal again, the timer will continue to work; the counter is not reset during the whole period. 110: Trigger mode, the slave mode timer starts the counter to work after receiving the rising edge signal of TRGI. 111: External clock mode 1; select the rising edge signal of TRGI as the clock source to drive the counter to work.
3	OCCSEL	R/W	OCREF Clear Source Select This bit is used to select OCREF clear source 0: OCREF_CLR 1: ETRF
6:4	TRGSEL	R/W	Select the trigger input signal (Trigger Input Signal Select) In order to avoid false edge detection when changing the bit value, it must be changed when SMFSEL=0. 000: Internal trigger ITR0 001: Internal trigger ITR1 010: Internal trigger ITR2 011: Internal trigger ITR3 100: Channel 1 input edge detector TIF_ED 101: Channel 1 post-filtering timer input TI1FP1

Field	Name	R/W	Description
			110: Channel 2 post-filtering timer input TI2FP2 111: External trigger input (ETRF)
7	MSMEN	R/W	Master/slave Mode Enable 0: Invalid 1: Enable the master/slave mode
11:8	ETFCFG	R/W	External Trigger Filter Configure 0000: Filter disabled, sampling by f_{DTS} 0001: DIV=1, N=2 0010: DIV=1, N=4 0011: DIV=1, N=8 0100: DIV=2, N=6 0101: DIV=2, N=8 0110: DIV=4, N=6 0111: DIV=4, N=8 1000: DIV=8, N=6 1001: DIV=8, N=8 1010: DIV=16, N=5 1011: DIV=16, N=6 1100: DIV=16, N=8 1101: DIV=32, N=5 1110: DIV=32, N=6 1111: DIV=32, N=8 Sampling frequency=timer clock frequency/DIV; the filter length=N, and a jump is generated by every N events.
13:12	ETPCFG	R/W	External Trigger Prescaler Configure The ETR (external trigger input) signal becomes ETRP after frequency division. The signal frequency of ETRP is at most 1/4 of TMRxCLK frequency; when ETR frequency is too high, the ETRP frequency must be reduced through frequency division. 00: The prescaler is disabled; 01: ETR signal 2 divided frequency 10: ETR signal 4 divided frequency 11: ETR signal 8 divided frequency
14	ECEN	R/W	External Clock Enable Mode2 0: Disable 1: Enable Setting ECEN bit has the same function as selecting external clock mode 1 to connect TRGI to ETRF; slave mode (reset, gating, trigger) can be used at the same time with external clock mode 2, but TRGI cannot be connected to ETRF in such case; when external clock mode 1 and external clock mode 2 are enabled at the same time, the input of external clock is ETRF.
15	ETPOL	R/W	External Trigger Polarity Configure This bit decides whether the external trigger ETR is reversed. 0: The external trigger ETR is not reversed, and the high level or rising edge is valid 1: The external trigger ETR is reversed, and the low level or falling edge is valid

Table 49 TMRx Internal Trigger Connection

Slave timer	ITR0 (TS=000)	ITR1 (TS=001)	ITR2 (TS=010)	ITR3 (TS=011)
TMR2	TMR1	TMR15	TMR3	TMR14
TMR3	TMR1	TMR2	TMR15	TMR14

15.6.4 DMA/Interrupt enable register (TMRx_DIEN)

Offset address: 0x0C

Reset value: 0x0000

Field	Name	R/W	Description
0	UIEN	R/W	Update interrupt Enable 0: Disable 1: Enable
1	CC1IEN	R/W	Capture/Compare Channel1 Interrupt Enable 0: Disable 1: Enable
2	CC2IEN	R/W	Capture/Compare Channel2 Interrupt Enable 0: Disable 1: Enable
3	CC3IEN	R/W	Capture/Compare Channel3 Interrupt Enable 0: Disable 1: Enable
4	CC4IEN	R/W	Capture/Compare Channel4 Interrupt Enable 0: Disable 1: Enable
5	Reserved		
6	TRGIEN	R/W	Trigger interrupt Enable 0: Disable 1: Enable
7	Reserved		
8	UDIEN	R/W	Update DMA Request Enable 0: Disable 1: Enable
9	CC1DEN	R/W	Capture/Compare Channel1 DMA Request Enable 0: Disable 1: Enable
10	CC2DEN	R/W	Capture/Compare Channel2 DMA Request Enable 0: Disable 1: Enable
11	CC3DEN	R/W	Capture/Compare Channel3 DMA Request Enable 0: Disable 1: Enable
12	CC4DEN	R/W	Capture/Compare Channel4 DMA Request Enable 0: Disable 1: Enable
13	Reserved		
14	TRGDEN	R/W	Trigger DMA Request Enable 0: Disable 1: Enable
15	Reserved		

15.6.5 State register (TMRx_STS)

Offset address: 0x10

Reset value: 0x0000

Field	Name	R/W	Description
0	UIFLG	RC_W0	Update Event Interrupt Generate Flag 0: Update event interrupt does not occur 1: Update event interrupt occurs When the counter value is reloaded or reinitialized, an update event will be generated. The bit is set to 1 by hardware and cleared by software; update events are generated in the following situations: (1) UD=0 on TMRx_CTRL1 register, and when the value of the repeat counter overruns/underruns, an update event will be generated; (2) URSSEL=0 and UD=0 on TMRx_CTRL1 register, configure UEG=1 on TMRx_CEG register to generate update event, and the counter needs to be initialized by software; (3) URSSEL=0 and UD=0 on TMRx_CTRL1 register, generate update event when the counter is initialized by trigger event.
1	CC1IFLG	RC_W0	Capture/Compare Channel1 Interrupt Flag When the capture/compare channel 1 is configured as output: 0: No matching occurred 1: The value of TMRx_CNT matches the value of TMRx_CC1 When the capture/compare channel 1 is configured as input: 0: Input capture did not occur 1: Input capture occurred When a capture event occurs, the bit is set to 1 by hardware, and it can be cleared by software or cleared when reading TMRx_CC1 register.
2	CC2IFLG	RC_W0	Capture/Compare Channel2 Interrupt Flag Refer to STS_CC1IFLG
3	CC3IFLG	RC_W0	Capture/Compare Channel3 Interrupt Flag Refer to STS_CC1IFLG
4	CC4IFLG	RC_W0	Capture/Compare Channel4 Interrupt Flag Refer to STS_CC1IFLG
5	Reserved		
6	TRGIFLG	RC_W0	Trigger Event Interrupt Generate Flag 0: Trigger event interrupt did not occur 1: Trigger event interrupt occurred After Trigger event is generated, this bit is set to 1 by hardware and cleared by software.
8:7	Reserved		
9	CC1RCFLG	RC_W0	Capture/compare Channel1 Repetition Capture Flag 0: Repeat capture does not occur 1: Repeat capture occurs The value of the counter is captured to TMRx_CCR1 register, and CC1IFLG=1; this bit is set to 1 by hardware and cleared by software only when the channel is configured as input capture.
10	CC2RCFLG	RC_W0	Capture/compare Channel2 Repetition Capture Flag Refer to STS_CC1RCFLG
11	CC3RCFLG	RC_W0	Capture/compare Channel3 Repetition Capture Flag Refer to STS_CC1RCFLG
12	CC4RCFLG	RC_W0	Capture/compare Channel4 Repetition Capture Flag Refer to STS_CC1RCFLG
15:13	Reserved		

15.6.6 Control event generation register (TMRx_CEG)

Offset address: 0x14

Reset value: 0x0000

Field	Name	R/W	Description
0	UEG	W	Update Event Generate 0: Invalid 1: Initialize the counter and generate the update event This bit is set to 1 by software, and cleared by hardware. Note: When an update event is generated, the counter of the prescaler will be cleared, but the prescaler factor remains unchanged. In the count-down mode, the counter reads the value of TMRx_AUTORLD; in center alignment mode or count-up mode, the counter will be cleared.
1	CC1EG	W	Capture/Compare Channel1 Event Generation 0: Invalid 1: Capture/Compare event is generated This bit is set to 1 by software and cleared automatically by hardware. If Channel 1 is in output mode: When CC1IFLG=1, if CC1IEN and CC1DEN bits are set, the corresponding interrupt and DMA request will be generated. If Channel 1 is in input mode: The value of the capture counter is stored in TMRx_CC1 register; configure CC1IFLG=1, and if CC1IEN and CC1DEN bits are also set, the corresponding interrupt and DMA request will be generated; at this time, if CC1IFLG=1, it is required to configure CC1RCFLG=1.
2	CC2EG	W	Capture/Compare Channel2 Event Generation Refer to CC1EG description
3	CC3EG	W	Capture/Compare Channel3 Event Generation Refer to CC1EG description
4	CC4EG	W	Capture/Compare Channel4 Event Generation Refer to CC1EG description
5	Reserved		
6	TEG	W	Trigger Event Generate 0: Invalid 1: Trigger event is generated This bit is set to 1 by software and cleared automatically by hardware.
15:8	Reserved		

15.6.7 Capture/Compare mode register 1 (TMRx_CCM1)

Offset address: 0x18

Reset value: 0x0000

The timer can be configured as input (capture mode) or output (compare mode) by CCxSEL bit. The functions of other bits of the register are different in input and output modes, and the functions of the same bit are different in output mode and input mode. The OCxx in the register describes the function of the channel in the output mode, and the ICxx in the register describes the function of the channel in the input mode.

Output compare mode:

Field	Name	R/W	Description
1:0	CC1SEL	R/W	Capture/Compare Channel 1 Select This bit defines the input/output direction and the selected input pin.

Field	Name	R/W	Description
			00: CC1 channel is output 01: CC1 channel is input, and IC1 is mapped on TI1 10: CC1 channel is input, and IC1 is mapped on TI2 11: CC1 channel is input, and IC1 is mapped on TRC, and only works in internal trigger input Note: This bit can be written only when the channel is closed (TMRx_CCEN register CC1EN=0).
2	OC1FEN	R/W	Output Compare Channel1 Fast Enable 0: Disable 1: Enable This bit is used to improve the response of the capture/compare output to the trigger input event.
3	OC1PEN	R/W	Output Compare Channel1 Preload Enable 0: Preloading function is disabled; write the value of TMRx_CC1 register through the program and it will work immediately. 1: Preloading function is enabled; write the value of TMRx_CC1 register through the program and it will work after an update event is generated. Note: When the protection level is 3 and the channel is configured as output, this bit cannot be modified. When the preload register is uncertain, PWM mode can be used only in single pulse mode (SPMEN=1); otherwise, the following output compare result is uncertain.
6:4	OC1MOD	R/W	Output Compare Channel1 Mode Configure 000: Freeze The output compare has no effect on OC1REF 001: The output value is high when matching. When the value of counter CNT matches the value CCx of capture/compare register, OC1REF will be forced to be at high level 010: The output value is low when matching. When the value of the counter matches the value of the capture/compare register, OC1REF will be forced to be at low level 011: Output flaps when matching. When the value of the counter matches the value of the capture/compare register, flap the level of OC1REF 100: The output is forced to be low Force OC1REF to be at low level 101: The output is forced to be high. Force OC1REF to be at high level 110: PWM mode 1 (set to high when the counter value<output compare value; otherwise, set to low) 111: PWM mode 2 (set to high when the counter value>output compare value; otherwise, set to low) Note: When the protection level is 3 and the channel is configured as output, this bit cannot be modified. In PWM modes 1 and 2, the OC1REF level changes when the compare result changes or when the output compare mode changes from freeze mode to PWM mode.
7	OC1CEN	R/W	Output Compare Channel1 Clear Enable 0: OC1REF is unaffected by ETRF input. 1: When high level of ETRF input is detected, OC1REF=0
9:8	CC2SEL	R/W	Capture/Compare Channel2 Select This bit defines the input/output direction and the selected input pin. 00: CC2 channel is output 01: CC2 channel is input, and IC2 is mapped on TI2 10: CC2 channel is input, and IC2 is mapped on TI1 11: CC2 channel is input, and IC2 is mapped on TRC, and only works in internal trigger input Note: This bit can be written only when the channel is closed (TMRx_CCEN register CC2EN=0).
10	OC2FEN	R/W	Output Compare Channel2 Preload Enable
11	OC2PEN	R/W	Output Compare Channel2 Buffer Enable

Field	Name	R/W	Description
14:12	OC2MOD	R/W	Output Compare Channel1 Mode
15	OC2CEN	R/W	Output Compare Channel2 Clear Enable

Input capture mode:

Field	Name	R/W	Description
1:0	CC1SEL	R/W	Capture/Compare Channel 1 Select 00: CC1 channel is output 01: CC1 channel is input, and IC1 is mapped on TI1 10: CC1 channel is input, and IC1 is mapped on TI2 11: CC1 channel is input, and IC1 is mapped on TRC, and only works in internal trigger input Note: This bit can be written only when the channel is closed (TMRx_CCEN bit CC1EN=0).
3:2	IC1PSC	R/W	Input Capture Channel 1 Prescaler Configure 00: PSC=1 01: PSC=2 10: PSC=4 11: PSC=8 PSC is prescaled factor, which triggers capture once every PSC events.
7:4	IC1F	R/W	Input Capture Channel 1 Filter Configure 0000: Filter disabled, sampling by f_{DTS} 0001: DIV=1, N=2 0010: DIV=1, N=4 0011: DIV=1, N=8 0100: DIV=2, N=6 0101: DIV=2, N=8 0110: DIV=4, N=6 0111: DIV=4, N=8 1000: DIV=8, N=6 1001: DIV=8, N=8 1010: DIV=16, N=5 1011: DIV=16, N=6 1100: DIV=16, N=8 1101: DIV=32, N=5 1110: DIV=32, N=6 1111: DIV=32, N=8 Sampling frequency=timer clock frequency/DIV; the filter length=N, indicating that a jump is generated by every N events.
9:8	CC2SEL	R/W	Capture/Compare Channel 2 Select 00: CC2 channel is output 01: CC2 channel is input, and IC2 is mapped on TI1 10: CC2 channel is input, and IC2 is mapped on TI2 11: CC2 channel is input, and IC2 is mapped on TRC, and only works in internal trigger input Note: This bit can be written only when the channel is closed (TMRx_CCEN register CC2EN=0).
11:10	IC2PSC	R/W	Input Capture Channel 2 Prescaler Configure
15:12	IC2F	R/W	Input Capture Channel 2 Filter Configure

15.6.8 Capture/Compare mode register 2 (TMRx_CCM2)

Offset address: 0x1C

Reset value: 0x0000

Refer to the description of the above CCM1 register.

Output compare mode:

Field	Name	R/W	Description
1:0	CC3SEL	R/W	Capture/Compare Channel 1 Select This bit defines the input/output direction and the selected input pin. 00: CC3 channel is output 01: CC3 channel is input, and IC3 is mapped on TI3 10: CC3 channel is input, and IC3 is mapped on TI4 11: CC3 channel is input, and IC3 is mapped on TRC, and only works in internal trigger input Note: This bit can be written only when the channel is closed (TMRx_CCEN register CC3EN=0).
2	OC3FEN	R/W	Output Compare Channel3 Fast Enable 0: Disable 1: Enable This bit is used to improve the response of the capture/compare output to the trigger input event.
3	OC3PEN	R/W	Output Compare Channel3 Preload Enable
6:4	OC3MOD	R/W	Output Compare Channel3 Mode Configure
7	OC3CEN	R/W	Output Compare Channel3 Clear Enable 0: OC3REF is unaffected by ETRF input. 1: When high level of ETRF input is detected, OC1REF=0
9:8	CC4SEL	R/W	Capture/Compare Channel 4 Select This bit defines the input/output direction and the selected input pin. 00: CC4 channel is output 01: CC4 channel is input, and IC4 is mapped on TI4 10: CC4 channel is input, and IC4 is mapped on TI3 11: CC4 channel is input, and IC4 is mapped on TRC, and only works in internal trigger input Note: This bit can be written only when the channel is closed (TMRx_CCEN register CC4EN=0).
10	OC4FEN	R/W	Output Compare Channel4 Preload Enable
11	OC4PEN	R/W	Output Compare Channel4 Buffer Enable
14:12	OC4MOD	R/W	Output Compare Channel4 Mode Configure
15	OC4CEN	R/W	Output Compare Channel4 Clear Enable

Input capture mode:

Field	Name	R/W	Description
1:0	CC3SEL	R/W	Capture/Compare Channel 3 Select 00: CC3 channel is output 01: CC3 channel is input, and IC3 is mapped on TI3 10: CC3 channel is input, and IC3 is mapped on TI4 11: CC3 channel is input, and IC3 is mapped on TRC, and only works in internal trigger input Note: This bit can be written only when the channel is closed (TMRx_CCEN register CC3EN=0).
3:2	IC3PSC	R/W	Input Capture Channel 3 Prescaler Configure 00: PSC=1 01: PSC=2 10: PSC=4 11: PSC=8 PSC is prescaled factor, which triggers capture once every PSC events.

Field	Name	R/W	Description
7:4	IC3F	R/W	Input Capture Channel 3 Filter Configure
9:8	CC4SEL	R/W	Capture/Compare Channel 4 Select 00: CC4 channel is output 01: CC4 channel is input, and IC4 is mapped on TI4 10: CC4 channel is input, and IC4 is mapped on TI3 11: CC4 channel is input, and IC4 is mapped on TRC, and only works in internal trigger input Note: This bit can be written only when the channel is closed (TMRx_CCEN register CC4EN=0).
11:10	IC4PSC	R/W	Input Capture Channel 4 Prescaler Configure
15:12	IC4F	R/W	Input Capture Channel 4 Filter Configure

15.6.9 Capture/Compare enable register (TMRx_CCEN)

Offset address: 0x20

Reset value: 0x0000

Field	Name	R/W	Description
0	CC1EN	R/W	Capture/Compare Channel1 Output Enable When CC1 is configured as output: 0: Output is disabled 1: Output is enabled When CC1 is configured as input: This bit determines whether the value CNT of the counter can be captured and enter TMRx_CC1 register 0: Capture is disabled 1: Capture is enabled
1	CC1POL	R/W	Capture/Compare Channel1 Output Polarity Configure When CC1 channel is configured as output: 0: OC1 high level is valid 1: OC1 low level is valid When CC1 channel is configured as input: CC1POL and CC1NPOL control the polarity of the triggered or captured signals TI1FP1 and TI2FP1 at the same time 00: Non-phase-inverting/rising edge: TIxFP1 is not reversed phase (triggered in gated and encoder mode), and is captured at the rising edge of TIxFP1 (reset trigger, capture, external clock and trigger mode). 01: Inverted phase/Falling edge: TIxFP1 is reversed phase (triggered in gated and encoder mode), and is captured at the rising edge of TIxFP1 (reset trigger, capture, external clock and trigger mode). 10: Reserved 11: Non-phase-inverting/Rising and falling edges: TIxFP1 is not reversed phase (triggered in gated mode), cannot be used in encoder mode), and is captured at the rising edge of TIxFP1 (reset trigger, capture, external clock and trigger mode).
2	Reserved		
3	CC1NPOL	R/W	Capture/Compare Channel1 Output Polarity Configure When CC1 channel is configured as output: CC1NPOL remains in cleared state all the time When CC1 channel is configured as input: This bit and CC1POL control the polarity of the triggered or captured signals TI1FP1 and TI2FP1 for the same time.

Field	Name	R/W	Description
4	CC2EN	R/W	Capture/Compare Channel2 Output Enable Refer to CCEN_CC1EN
5	CC2POL	R/W	Capture/Compare Channel2 Output Polarity Configure Refer to CCEN_CC1POL
6	Reserved		
7	CC2NPOL	R/W	Capture/Compare Channel2 Output Polarity Configure Refer to CCEN_CC1NPOL
8	CC3EN	R/W	Capture/Compare Channel3 Output Enable Refer to CCEN_CC1EN
9	CC3POL	R/W	Capture/Compare Channel3 Output Polarity Configure Refer to CCEN_CC1POL
10	Reserved		
11	CC3NPOL	R/W	Capture/Compare Channel3 Output Polarity Configure Refer to CCEN_CC1NPOL
12	CC4EN	R/W	Capture/Compare Channel4 Output Enable Refer to CCEN_CC1EN
13	CC4POL	R/W	Capture/Compare Channel4 Output Polarity Configure Refer to CCEN_CC1POL
14	Reserved		
15	CC4NPOL	R/W	Capture/Compare Channel4 Output Polarity Configure Refer to CCEN_CC1NPOL

Table 50 Output Control Bit of Standard OCx Channel

CCxEN bit	OCx output state
0	Output is disabled (OCx=0, OCx_EN=0)
1	OCx=OCxREF+polarity, OCx_EN=1

Note: The state of external I/O pin connected to the standard OCx channel depends on the state of the OCx channel and the GPIO and AFIO registers.

15.6.10 Counter register (TMRx_CNT)

Offset address: 0x24

Reset value: 0x0000

Field	Name	R/W	Description
15:0	CNT	R/W	Counter Value
31:16	CNT	R/W	Counter Value (only TMR2)

15.6.11 Prescaler register (TMRx_PSC)

Offset address: 0x28

Reset value: 0x0000

Field	Name	R/W	Description
15:0	PSC	R/W	Prescaler Value Clock frequency of counter (CK_CNT)= $f_{CK_PSC}/(PSC+1)$

15.6.12 Auto reload register (TMRx_AUTORLD)

Offset address: 0x2C

Reset value: 0xFFFF FFFF

Field	Name	R/W	Description
15:0	AUTORLD	R/W	Auto Reload Value When the value of auto reload is empty, the counter will not count.
31:16	AUTORLD	R/W	Auto Reload Value (only TMR2)

15.6.13 Channel 1 capture/compare register (TMRx_CC1)

Offset address: 0x34

Reset value: 0x0000

Field	Name	R/W	Description
15:0	CC1	R/W	Capture/Compare Channel 1 Value When the capture/compare channel 1 is configured as input mode: CC1 contains the counter value transmitted by the last input capture channel 1 event. When the capture/compare channel 1 is configured as output mode: CC1 contains the current load capture/compare register value Compare the value CC1 of the capture and compare channel 1 with the value CNT of the counter to generate the output signal on OC1. When the output compare preload is disabled (OC1PEN=0 for TMRx_CCM1 register), the written value will immediately affect the output compare results; If the output compare preload is enabled (OC1PEN=1 for TMRx_CCM1 register), the written value will affect the output compare result when an update event is generated.
31:16	CC1	R/W	Capture/Compare Channel1 Value (only TMR2)

15.6.14 Channel 2 capture/compare register (TMRx_CC2)

TMR2 Channel 2 capture/compare register (TMRx_CC2)

Offset address: 0x38

Reset value: 0x0000

Field	Name	R/W	Description
31:0	CC2	R/W	Capture/Compare Channel 2 Value Refer to TMRx_CC1

TMR3 Channel 2 capture/compare register (TMRx_CC2)

Offset address: 0x38

Reset value: 0x0000

Field	Name	R/W	Description
15:0	CC2	R/W	Capture/Compare Channel 2 Value Refer to TMRx_CC1

15.6.15 Channel 3 capture/compare register (TMRx_CC3)

TMR2 Channel 3 capture/compare register (TMRx_CC3)

Offset address: 0x3C

Reset value: 0x0000

Field	Name	R/W	Description
31:0	CC3	R/W	Capture/Compare Channel 3 Value Refer to TMRx_CC1

TMR3 Channel 3 capture/compare register (TMRx_CC3)

Offset address: 0x3C

Reset value: 0x0000

Field	Name	R/W	Description
-------	------	-----	-------------

Field	Name	R/W	Description
15:0	CC3	R/W	Capture/Compare Channel 3 Value Refer to TMRx_CC1

15.6.16 Channel 4 capture/compare register (TMRx_CC4)

TMR2 Channel 4 capture/compare register (TMRx_CC4)

Offset address: 0x40

Reset value: 0x0000

Field	Name	R/W	Description
31:0	CC4	R/W	Capture/Compare Channel 4 Value Refer to TMRx_CC1

TMR3 Channel 4 capture/compare register (TMRx_CC4)

Offset address: 0x40

Reset value: 0x0000

Field	Name	R/W	Description
15:0	CC4	R/W	Capture/Compare Channel 4 Value Refer to TMRx_CC1

15.6.17 DMA control register (TMRx_DCTRL)

Offset address: 0x48

Reset value: 0x0000

Field	Name	R/W	Description
4:0	DBADDR	R/W	DMA Base Address Setup These bits define the base address of DMA in continuous mode (when reading or writing TMRx_DMADDR register), and DBADDR is defined as the offset from the address of TMRx_CTRL1 register: 00000: TMRx_CTRL1 00001: TMRx_CTRL2 00010: TMRx_SMCTRL
7:5	Reserved		
12:8	DBLEN	R/W	DMA Burst Transfer Length Setup These bits define the transfer length and transfer times of DMA in continuous mode. The data transferred can be 16 bits and 8 bits. When reading/writing TMRx_DMADDR register, the timer will conduct a continuous transmission; 00000: Transmission for 1 time 00001: Transmission for 2 times 00010: Transmission for 3 times 10001: Transmission for 18 times The transmission address formula is as follows: Transmission address=TMRx_CTRL1 address (slave address) +DBADDR+DMA index; DMA index=DBLEN For example: DBLEN=7, DBADDR=TMR1_CTRL1 (slave address) means the address of the data to be transmitted, while the address +DBADDR+7 of TMRx_CTRL1 means the address of the data to be written/read, Data transmission will occur to: TMRx_CTRL1 address + seven registers starting from DBADDR. The data transmission will change according to different DMA data length: When the transmission data is set to 16 bits, the data will be transmitted to

Field	Name	R/W	Description
			seven registers When the transmission data is set to 8 bits, the data of the first register is the MSB bit of the first data, the data of the second register is the LSB bit of the first data, and the data will still be transmitted to seven registers.
15:13			Reserved

15.6.18 DMA address register of continuous mode (TMRx_DMADDR)

Offset address: 0x4C

Reset value: 0x0000

Field	Name	R/W	Description
15:0	DMADDR	R/W	<p>DMA Register for Burst Transfer</p> <p>Read or write operation access of TMRx_DMADDR register may lead to access operation of the register in the following address: $TMRx_CTRL1 \text{ address} + (DBADDR + DMA \text{ index}) \times 4$</p> <p>Wherein: "TMRx_CTRL1 address" is the address of control register 1 (TMRx_CTRL1); "DBADDR" is the base address defined in TMRx_DCTRL register; "DMA index" is the offset automatically controlled by DMA, and it depends on DBLEN defined in TMRx_DCTRL register.</p>

16 General-purpose Timer (TMR14)

16.1 Introduction

The general-purpose timer takes the time base unit as the core, and has the functions of input capture and output compare, and can be used to measure the pulse width, frequency and duty cycle, and generate the output waveform. It includes a 16-bit auto reload counter (realize count-up, count-down and center alignment count).

16.2 Main Characteristics

- (1) Timebase unit
 - Counter: 16-bit counter, count-up, count-down and center alignment count
 - Prescaler: 16-bit programmable prescaler
 - Auto reloading function
- (2) Clock source
 - Internal clock
- (3) Timer function
 - Input capture
 - Output compare
 - PWM output mode
 - Forced output mode
- (4) Interrupt and DMA request event
 - Update event (counter overrun/underrun, counter initialization)
 - Input capture
 - Output compare

16.3 Structure Block Diagram

Figure 41 General-purpose Timer TMR14 Structure Block Diagram

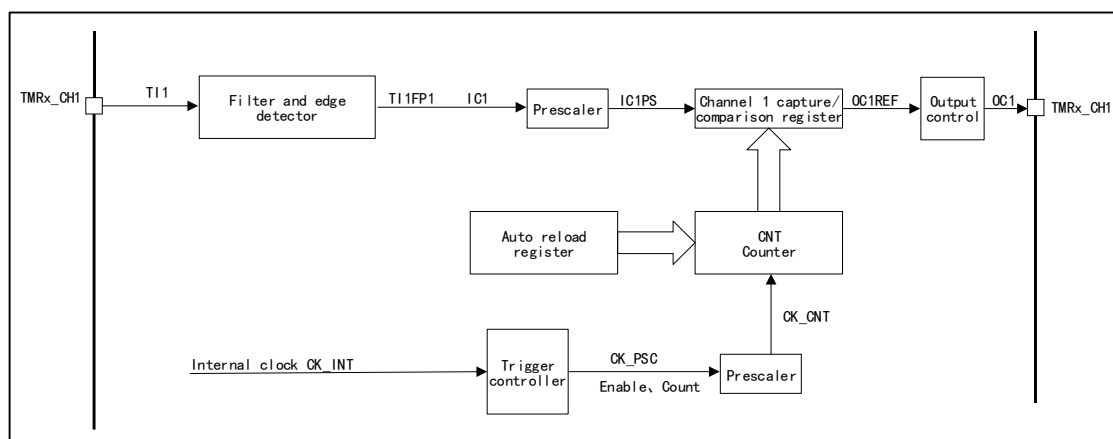

16.4 Functional Description

16.4.1 Clock Source

Internal clock

It is TMR14_CLK from RCM, namely the driving clock of the timer; when the slave mode controller is disabled, the clock source CK_PSC of the prescaler is driven by the internal clock CK_INT.

16.4.2 Timebase Unit

The time base unit in the general-purpose timer contains three registers

- Counter register (CNT) 16 bits
- Auto reload register (AUTORLD) 16 bits
- Prescaler (PSC) 16 bits

Counter CNT

There are three counting modes for the counter in the general-purpose timer

- Count-up mode
- Count-down mode
- Center alignment mode

Count-up mode

Set to the count-up mode by CNTDIR bit of configuration control register (TMR14_CTRL1).

When the counter is in count-up mode, the counter will count up from 0; every time a pulse is generated, the counter will increase by 1 and when the value of the counter (TMR14_CNT) is equal to that of the auto reload (TMR14_AUTORLD), the counter will start to count again from 0, a count-up overrun event will be generated, and the value of the auto reload (TMR14_AUTORLD) is written in advance.

When the counter overruns, an update event will be generated. At this time, the repeat count register, the auto reload register and the prescaler register will be updated. The update event can be disabled by UD bit of configuration control register TMR14_CTRL1.

The figure below is Timing Diagram when Division Factor is 1 or 2 in Count-up Mode

Figure 42 Timing Diagram when Division Factor is 1 or 2 in Count-up Mode

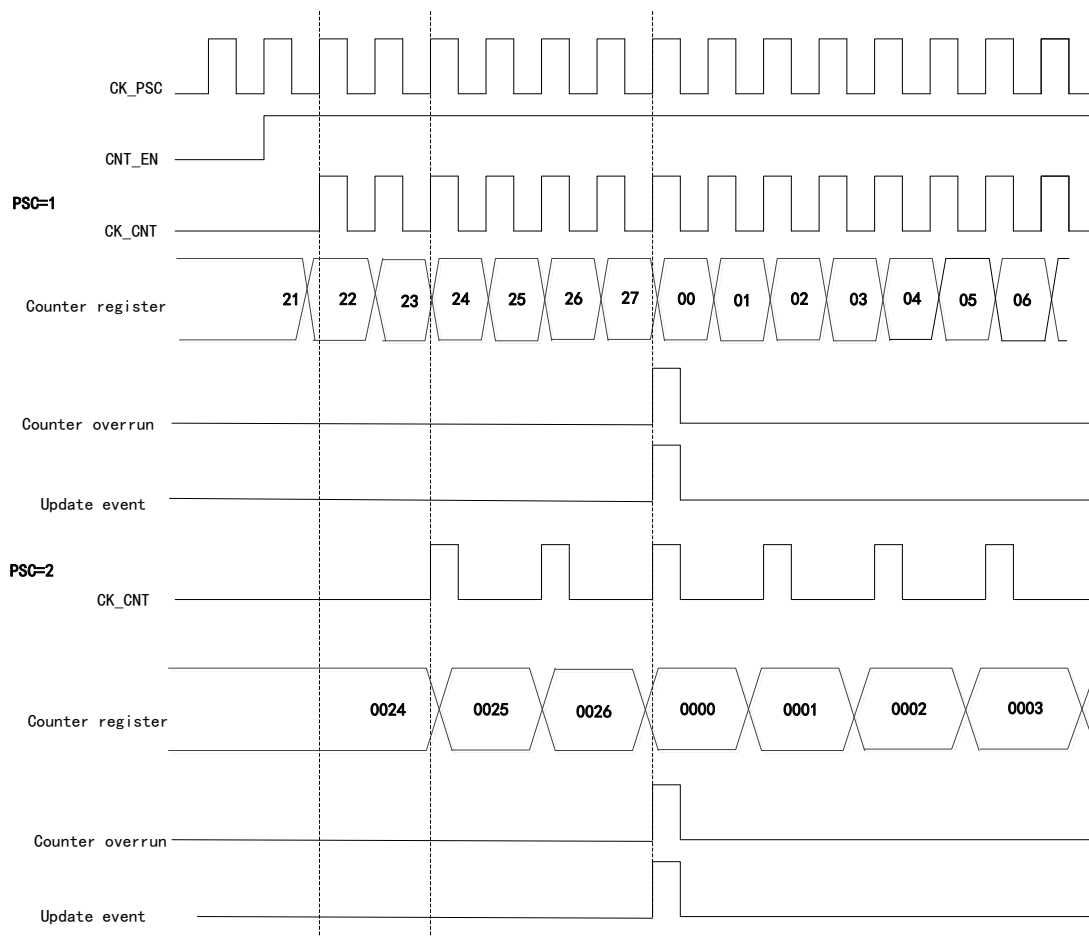

Count-down mode

Set to the count-down mode by CNTDIR bit of configuration control register (TMR14_CTRL1).

When the counter is in count-down mode, the counter will start to count down from the value of the auto reload (TMR14_AUTORLD); every time a pulse is generated, the counter will decrease by 1 and when it becomes 0, the counter will start to count again from (TMR14_AUTORLD), meanwhile, a count-down overrun event will be generated, and the value of the auto reload (TMR14_AUTORLD) is written in advance.

When the counter overruns, an update event will be generated. At this time, the repeat count register, the auto reload register and the prescaler register will be updated. The update event can be disabled by configuring the UD bit of the TMR14_CTRL1 register.

The figure below is Timing Diagram when Division Factor is 1 or 2 in Count-down Mode

Figure 43 Timing Diagram when Division Factor is 1 or 2 in Count-down Mode

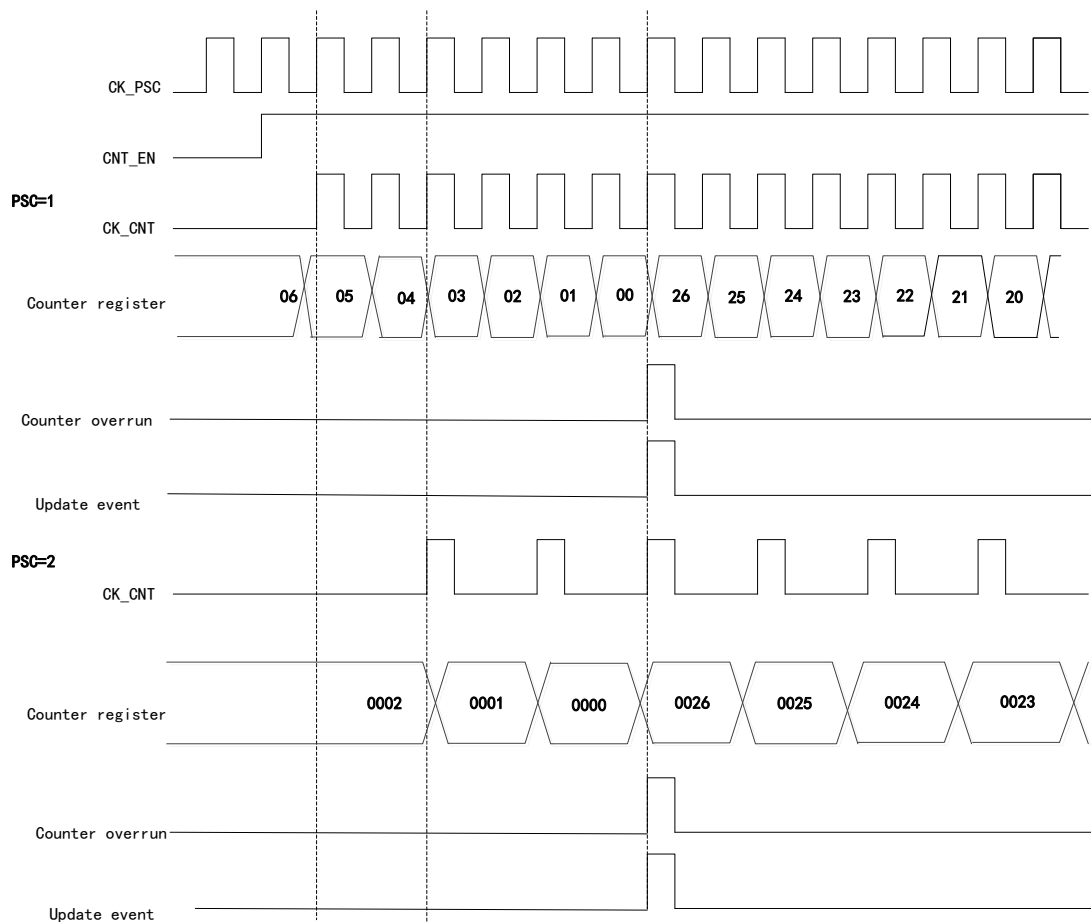

Center alignment mode

Set to the center alignment mode by CNTDIR bit of configuration control register (TMR14_CTRL1).

When the counter is in central alignment mode, the counter counts up from 0 to the value of auto reload (TMR14_AUTORLD), then counts down to 0 from the value of the auto reload (TMR14_AUTORLD), which will repeat; in counting up, when the counter value is (AUTORLD-1), a counter overrun event will be generated; in counting down, when the counter value is 1, a counter underrun event will be generated.

The figure below is Timing Diagram when Division Factor is 1 or 2 in Center Alignment Mode

Figure 44 Timing Diagram when Division Factor is 1 or 2 in Center Alignment Mode

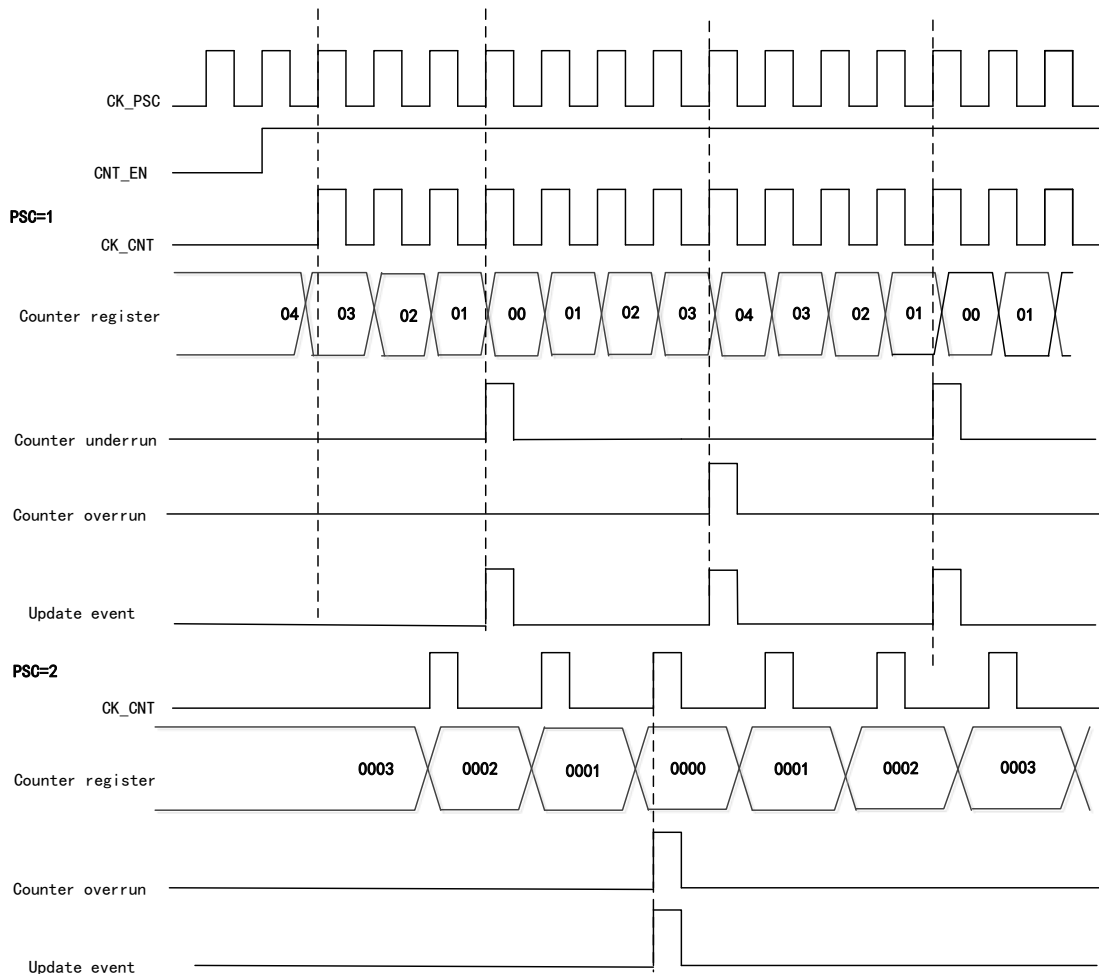

Prescaler PSC

The prescaler is 16 bits and programmable, and it can divide the clock frequency of the counter to any value between 1 and 65536 (controlled by TMR14_PSC register), and after frequency division, the clock will drive the counter CNT to count. The prescaler has a buffer, which can be changed during running.

16.4.3 Input Capture

Input capture channel

The general-purpose timer has four independent capture/compare channels, each of which is surrounded by a capture/compare register.

In the input capture, the measured signal will enter from the external pin T1/2/3/4 of the timer, first pass through the edge detector and input filter, and then into the capture channel. Each capture channel has a corresponding capture register. When the capture occurs, the value of the counter CNT will be latched in the capture register CCx. Before entering the capture register, the signal will pass through the prescaler, which is used to set how many events to capture at a time.

Input capture application

Input capture is used to capture external events, and can give the time flag to indicate the occurrence time of the event and measure the pulse jump edge events (measure the frequency or pulse width), for example, if the selected edge appears on the input pin, the TMR14_CCx register will capture the current value of the counter and the CCxIFLG bit of the state register TMR14_STS will be set to 1; if CCxIEN=1, an interrupt will be generated.

In capture mode, the timing, frequency, period and duty cycle of a waveform can be measured. In the input capture mode, the edge selection is set to rising edge detection. When the rising edge appears on the capture channel, the first capture occurs, at this time, the value of the counter CNT will be latched in the capture register CCx; at the same time, it will enter the capture interrupt, a capture will be recorded in the interrupt service program and the value will be recorded. When the next rising edge is detected, the second capture occurs, the value of counter CNT will be latched in capture register CCx again, at this time, it will enter the capture interrupt again, the value of capture register will be read, and the cycle of this pulse signal will be obtained through capture.

16.4.4 Output Compare

There are eight modes of output compare: freeze, channel x is valid level when matching, channel x is invalid level when matching, flip, force is invalid, force is valid, PWM mode 1 and PWM mode 2, which are configured by OCxMOD bit in TMR14_CCMx register and can control the waveform of output signal in output compare mode.

Output compare application

In the output compare mode, the position, polarity, frequency and time of the pulse generated by the timer can be controlled.

When the value of the counter is equal to that of the capture/compare register, the channel output can be set as high level, low level or flip by configuring the OCxMOD bit in TMR14_CCMx register and the CCxPOL bit in the output polarity TMR14_CCEN register.

When CCxIFLG=1 in TMR14_STS register, if CCxIEN=1 in TMRx_DIEN register, an interrupt will be generated; if CCDSEL=1 in TMR14_CTRL2 register, DMA request will be generated.

16.4.5 PWM Output Mode

PWM mode is an adjustable pulse signal output by the timer. The pulse width of the signal is determined by the value of the compare register CCx, and the cycle is determined by the value of the auto reload AUTORLD.

PWM output mode contains PWM mode 1 and PWM mode 2; PWM mode 1 and PWM mode 2 are divided into count-up, count-down and edge alignment counting; in PWM mode 1, if the value of the counter CNT is less than the value of the compare register CCx, the output level will be valid; otherwise, it will be invalid.

Set the timing diagram in PWM mode1 when CCx=5, AUTORLD=7

Figure 45 PWM1 Count-up Mode Timing Diagram

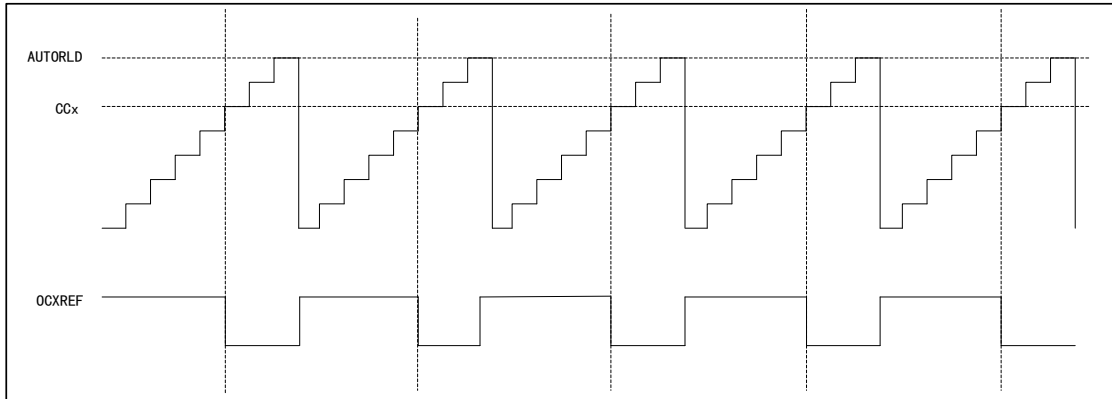

Figure 46 PWM1 Count-down Mode Timing Diagram

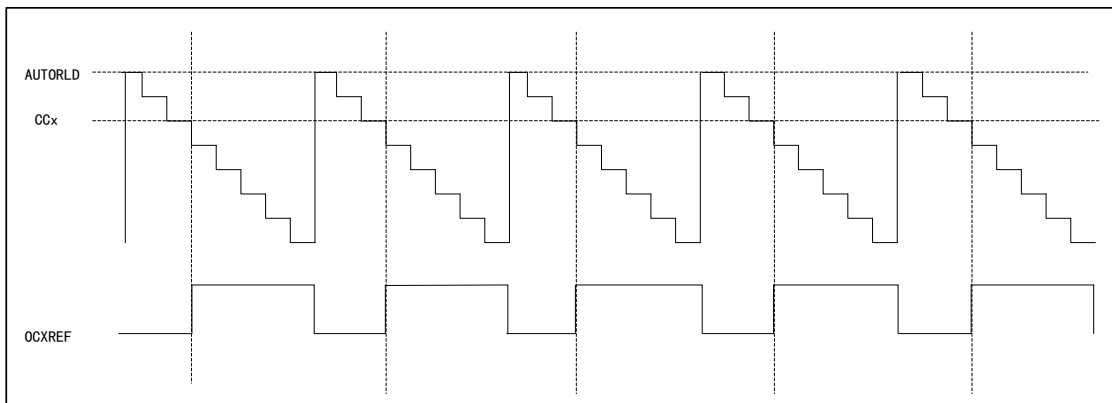
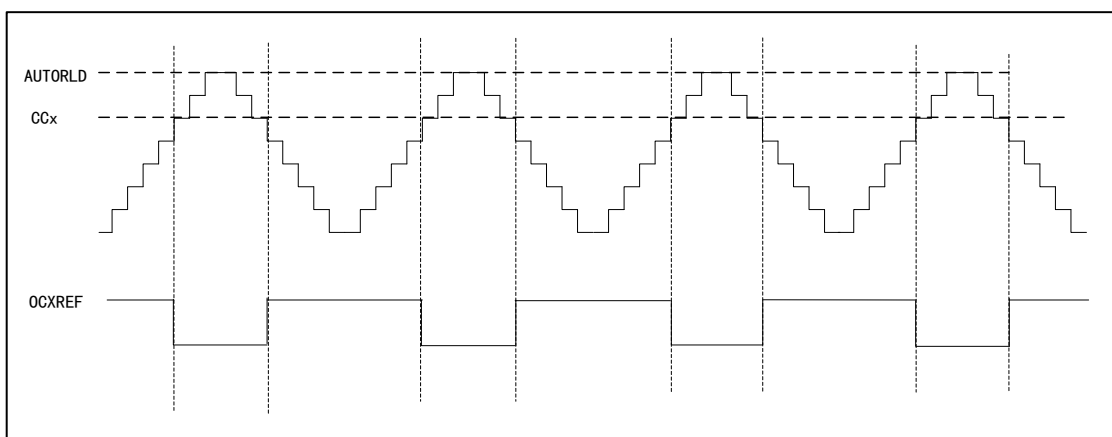

Figure 47 PWM1 Center Alignment Mode Timing Diagram



In PWM mode 2, if the value of the counter CNT is less than that of the compare register CCx, the output level will be invalid; otherwise, it will be valid.

Set the timing diagram in PWM mode 2 when CCx=5, AUTORLD=7

Figure 48 PWM2 Count-up Mode Timing Diagram

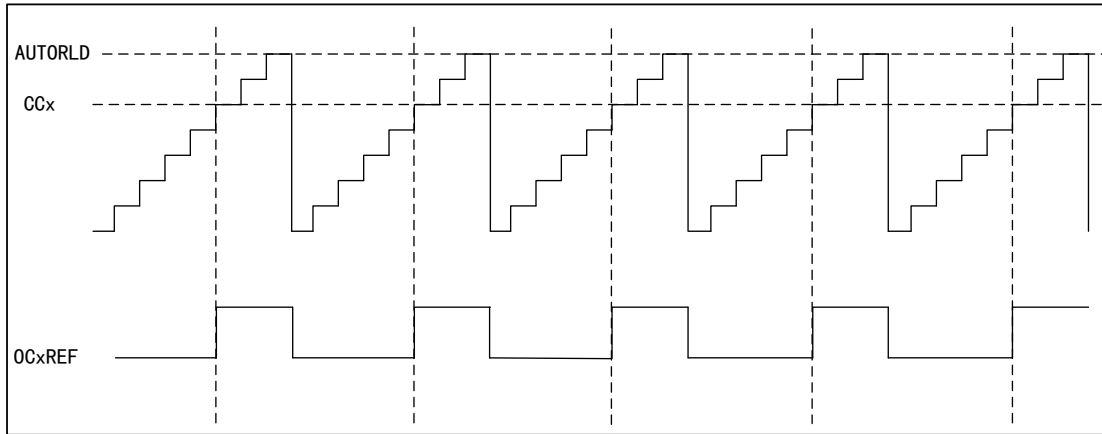

Figure 49 PWM2 Count-down Mode Timing Diagram

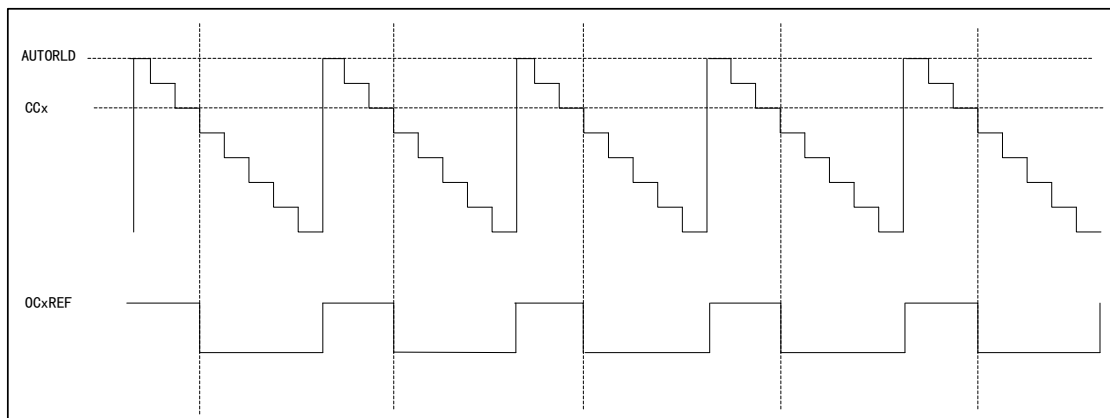
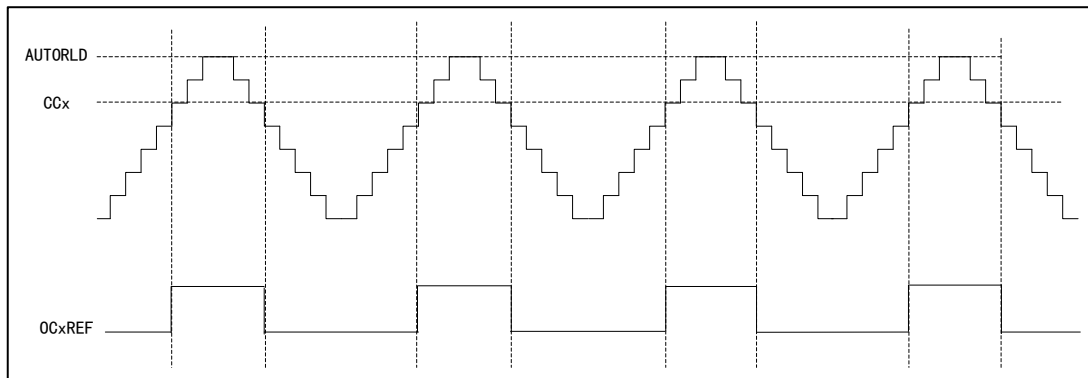

Figure 50 PWM2 Center Alignment Mode Timing Diagram



16.4.6 Forced Output Mode

In the forced output mode, the compare result is ignored, and the corresponding level is directly output according to the configuration instruction.

- CCxSEL=00 for TMR14_CCMx register, set CCx channel as output
- OCxMOD=100/101 for TMR14_CCMx register, set to force OCxREF signal to invalid/valid state

In this mode, the corresponding interrupt and DMA request will still be generated.

16.5 Register Address Mapping

In the following table, all registers of TMR14 are mapped to a 16-bit addressable (address) space.

Table 51 TMR14 Register Address Mapping

Register name	Description	Offset address
TMR14_CTRL1	Control register 1	0x00
TMR14_DIEN	DMA/Interrupt enable register	0x0C
TMR14_STS	State register	0x10
TMR14_CEG	Control event generation register	0x14
TMR14_CCM1	Capture/Compare mode register 1	0x18
TMR14_CCEN	Capture/Compare enable register	0x20
TMR14_CNT	Counter register	0x24
TMR14_PSC	Prescaler register	0x28
TMR14_AUTORLD	Auto reload register	0x2C
TMR14_CC1	Channel 1 capture/compare register	0x34
TMR14_OPT	Option register	0x50

16.6 Register Functional Description

16.6.1 Control register 1 (TMR14_CTRL1)

Offset address: 0x00

Reset value: 0x0000

Field	Name	R/W	Description
0	CNTEN	R/W	Counter Enable 0: Disable 1: Enable When the timer is configured as external clock, gated mode and encoder mode, it is required to write 1 to the bit by software to start regular work; when it is configured as the trigger mode, it can be written to 1 by hardware.
1	UD	R/W	Update Disable Update event can cause AUTORLD, PSC and CCx to generate the value of update setting. 0: Update event is allowed (UEV) An update event can occur in any of the following situations: The counter overruns/underruns;

Field	Name	R/W	Description
			Set UEG bit; Update generated by slave mode controller. 1: Update event is disabled
2	URSSEL	R/W	Update Request Source Select If interrupt or DMA is enabled, the update event can generate update interrupt or DMA request. Different update request sources can be selected through this bit. 0: The counter overruns or underruns Set UEG bit Update generated by slave mode controller 1: The counter overruns or underruns
6:3	Reserved		
7	ARPEN	R/W	TMR14_AUTORLD Register Auto-reload Preload Enable When the buffer is disabled, the program modification TMR14_AUTORLD will immediately modify the values loaded to the counter; when the buffer is enabled, the program modification TMR14_AUTORLD will modify the values loaded to the counter in the next update event. 0: Disable 1: Enable
9:8	CLKDIV	R/W	Clock Divide Factor For the configuration of dead time and digital filter, CK_INT provides the clock, and the dead time and the clock of the digital filter can be adjusted by setting this bit. 00: $t_{DTS}=t_{CK_INT}$ 01: $t_{DTS}=2 \times t_{CK_INT}$ 10: $t_{DTS}=4 \times t_{CK_INT}$ 11: Reserved
15:10	Reserved		

16.6.2 DMA/Interrupt enable register (TMR14_DIEN)

Offset address: 0x0C

Reset value: 0x0000

Field	Name	R/W	Description
0	UIEN	R/W	Update interrupt Enable 0: Disable 1: Enable
1	CC1IEN	R/W	Capture/Compare Channel1 Interrupt Enable 0: Disable 1: Enable
15:2	Reserved		

16.6.3 State register (TMR14_STS)

Offset address: 0x10

Reset value: 0x0000

Field	Name	R/W	Description
0	UIFLG	RC_W0	Update Event Interrupt Generate Flag 0: Update event interrupt does not occur 1: Update event interrupt occurs When the counter value is reloaded or reinitialized, an update event will be generated. The bit is set to 1 by hardware and cleared by software; update events are generated in the following situations: (1) UD=0 on TMR14_CTRL1 register, and when the value of the repeat counter overruns/underruns, an update event will be generated; (2) URSEL=0 and UD=0 on TMR14_CTRL1 register, configure UG = 1 on TMR14_CEG register to generate an update event, and the counter needs to be initialized by software; (3) URSEL=0 and UD=0 on TMR14_CTRL1 register, generate an update event when the counter is initialized by trigger event.
1	CC1IFLG	RC_W0	Capture/Compare Channel1 Interrupt Flag When the capture/compare channel 1 is configured as output: 0: No matching occurred 1: The value of TMR14_CNT matches the value of TMR14_CC1 When the capture/compare channel 1 is configured as input: 0: Input capture did not occur 1: Input capture occurred It is set to 1 by hardware when a capture event occurs, and can be cleared by software or by reading TMR14_CC1 register.
8:7	Reserved		
9	CC1RCFLG	RC_W0	Capture/compare Channel1 Repetition Capture Flag 0: Repeat capture does not occur 1: Repeat capture occurs The value of the counter is captured to TMR14_CC1 register, and CC1IFLG=1; this bit is set to 1 by hardware and cleared by software only when the channel is configured as input capture.
15:10	Reserved		

16.6.4 Control event generation register (TMR14_CEG)

Offset address: 0x14

Reset value: 0x0000

Field	Name	R/W	Description
0	UEG	W	Update Event Generate 0: Invalid 1: Initialize the counter and generate the update event This bit is set to 1 by software, and cleared by hardware. Note: When an update event is generated, the counter of the prescaler will be cleared, but the prescaler factor remains unchanged. In count-down mode, the counter will read the value of TMR14_AUTORLD; in center alignment mode or count-up mode, the counter will be cleared.
1	CC1EG	W	Capture/Compare Channel1 Event Generation 0: Invalid 1: Capture/Compare event is generated This bit is set to 1 by software and cleared automatically by hardware. If Channel 1 is in output mode: When CC1IFLG=1, if CC1IEN and CC1DEN bits are set, the corresponding interrupt and DMA request will be generated.

Field	Name	R/W	Description
			<p>If Channel 1 is in input mode:</p> <p>The value of the capture counter is stored in TMR14_CC1 register; configure CC1IFLG=1, and if CC1IEN and CC1DEN bits are also set, the corresponding interrupt and DMA request will be generated; at this time, if CC1IFLG=1, it is required to configure CC1RCFLG=1.</p>
15:2			Reserved

16.6.5 Capture/Compare mode register 1 (TMR14_CCM1)

Offset address: 0x18

Reset value: 0x0000

The timer can be configured as input (capture mode) or output (compare mode) by CCxSEL bit. The functions of other bits of the register are different in input and output modes, and the functions of the same bit are different in output mode and input mode. The OCx in the register describes the function of the channel in the output mode, and the ICxx in the register describes the function of the channel in the input mode.

Output compare mode:

Field	Name	R/W	Description
1:0	CC1SEL	R/W	<p>Capture/Compare Channel 1 Select</p> <p>This bit defines the input/output direction and the selected input pin.</p> <p>00: CC1 channel is output</p> <p>01: CC1 channel is input, and IC1 is mapped on TI1</p> <p>10: CC1 channel is input, and IC1 is mapped on TI2</p> <p>11: CC1 channel is input, and IC1 is mapped on TRC, and only works in internal trigger input</p> <p>Note: This bit can be written only when the channel is closed (TMR14_CCEN register CC1EN=0).</p>
2	OC1FEN	R/W	<p>Output Compare Channel1 Fast Enable</p> <p>0: Disable</p> <p>1: Enable</p> <p>This bit is used to improve the response of the capture/compare output to the trigger input event.</p>
3	OC1PEN	R/W	<p>Output Compare Channel1 Preload Enable</p> <p>0: Preloading function is disabled; write the value of TMR14_CC1 register through the program and it will work immediately.</p> <p>1: Preloading function is enabled; write the value of TMR14_CC1 register through the program and it will work after an update event is generated.</p> <p>Note: When the protection level is 3 and the channel is configured as output, this bit cannot be modified. When the preload register is uncertain, PWM mode can be used only in single pulse mode (SPMEN=1); otherwise, the following output compare result is uncertain.</p>
6:4	OC1MOD	R/W	<p>Output Compare Channel1 Mode Configure</p> <p>000: Freeze The output compare has no effect on OC1REF</p> <p>001: The output value is high when matching. When the value of counter CNT matches the value CCx of capture compare register, OC1REF will be forced to be at high level</p> <p>010: The output value is low when matching. When the value of the counter matches the value of the capture compare register, OC1REF will be forced to be at low level</p> <p>011: Output flaps when matching. When the value of the counter matches the value of the capture compare register, flap the level of OC1REF</p> <p>100: The output is forced to be low Force OC1REF to be at low level</p> <p>101: The output is forced to be high. Force OC1REF to be at high level</p> <p>110: PWM mode 1 (set to high when the counter value < output compare value; otherwise, set to low)</p> <p>111: PWM mode 2 (set to high when the counter value > output compare value; otherwise, set to low)</p> <p>Note: When the protection level is 3 and the channel is configured as output,</p>

Field	Name	R/W	Description
			this bit cannot be modified. In PWM modes 1 and 2, the OC1REF level changes when the compare result changes or when the output compare mode changes from freeze mode to PWM mode.
15:7	Reserved		

Input capture mode:

Field	Name	R/W	Description
1:0	CC1SEL	R/W	Capture/Compare Channel 1 Select 00: CC1 channel is output 01: CC1 channel is input, and IC1 is mapped on TI1 10: CC1 channel is input, and IC1 is mapped on TI2 11: CC1 channel is input, and IC1 is mapped on TRC, and only works in internal trigger input Note: This bit can be written only when the channel is closed (TMR14_CCEN bit CC1EN=0).
3:2	IC1PSC	R/W	Input Capture Channel 1 Prescaler Configure 00: PSC=1 01: PSC=2 10: PSC=4 11: PSC=8 PSC is prescaled factor, which triggers capture once every PSC events.
7:4	IC1F	R/W	Input Capture Channel 1 Filter Configure 0000: Filter disabled, sampling by f_{DTS} 0001: DIV=1, N=2 0010: DIV=1, N=4 0011: DIV=1, N=8 0100: DIV=2, N=6 0101: DIV=2, N=8 0110: DIV=4, N=6 0111: DIV=4, N=8 1000: DIV=8, N=6 1001: DIV=8, N=8 1010: DIV=16, N=5 1011: DIV=16, N=6 1100: DIV=16, N=8 1101: DIV=32, N=5 1110: DIV=32, N=6 1111: DIV=32, N=8 Sampling frequency=timer clock frequency/DIV; the filter length=N, indicating that a jump is generated by every N events.
15:8	Reserved		

16.6.6 Capture/Compare enable register (TMR14_CCEN)

Offset address: 0x20

Reset value: 0x0000

Field	Name	R/W	Description
0	CC1EN	R/W	Capture/Compare Channel1 Output Enable When the capture/compare channel 1 is configured as output: 0: Output is disabled 1: Output is enabled When the capture/compare channel 1 is configured as input: This bit determines whether the value CNT of the counter can be captured and enter TMR14_CC1 register 0: Capture is disabled

Field	Name	R/W	Description
			1: Capture is enabled
1	CC1POL	R/W	Capture/Compare Channel1 Output Polarity Configure When CC1 channel is configured as output: 0: OC1 high level is valid 1: OC1 low level is valid When CC1 channel is configured as input: CC1POL and CC1NPOL control the polarity of the triggered or captured signals TI1FP1 and TI2FP1 at the same time 00: Non-phase-inverting/rising edge: TIxFP1 is not reversed phase (triggered in gated and encoder mode), and is captured at the rising edge of TIxFP1 (reset trigger, capture, external clock and trigger mode). 01: Inverted phase/Falling edge: TIxFP1 is reversed phase (triggered in gated and encoder mode), and is captured at the rising edge of TIxFP1 (reset trigger, capture, external clock and trigger mode). 10: Reserved 11: Non-phase-inverting/Rising and falling edges: TIxFP1 is not reversed phase (triggered in gated mode, cannot be used in encoder mode), and is captured at the rising edge of TIxFP1 (reset trigger, capture, external clock and trigger mode).
2	Reserved		
3	CC1NPOL	R/M	Capture/Compare Channel1 Output Polarity Configure When CC1 channel is configured as output: CC1NPOL remains in cleared state all the time When CC1 channel is configured as input: This bit and CC1POL control the polarity of the triggered or captured signals TI1FP1 and TI2FP1 at the same time.
15:4	Reserved		

Table 52 Output Control Bit of Standard OCx Channel

CCxEN bit	OCx output state
0	Output is disabled (OCx=0, OCx_EN=0)
1	OCx=OCxREF+polarity, OCx_EN=1

Note: The state of external I/O pin connected to the standard OCx channel depends on the state of the OCx channel and the GPIO and AFIO registers.

16.6.7 Counter register (TMR14_CNT)

Offset address: 0x24

Reset value: 0x0000

Field	Name	R/W	Description
15:0	CNT	R/W	Counter Value

16.6.8 Prescaler register (TMR14_PSC)

Offset address: 0x28

Reset value: 0x0000

Field	Name	R/W	Description
-------	------	-----	-------------

Field	Name	R/W	Description
15:0	PSC	R/W	Prescaler Value Clock frequency of counter (CK_CNT)= $f_{CK_PSC}/(PSC+1)$

16.6.9 Auto reload register (TMR14_AUTORLD)

Offset address: 0x2C

Reset value: 0xFFFF

Field	Name	R/W	Description
15:0	AUTORLD	R/W	Auto Reload Value When the value of auto reload is empty, the counter will not count.

16.6.10 Channel 1 capture/compare register (TMR14_CC1)

Offset address: 0x34

Reset value: 0x0000

Field	Name	R/W	Description
15:0	CC1	R/W	Capture/Compare Channel 1 Value When the capture/compare channel 1 is configured as input mode: CC1 contains the counter value transmitted by the last input capture channel 1 event. When the capture/compare channel 1 is configured as output mode: CC1 contains the current load capture/compare register value Compare the value CC1 of the capture and compare channel 1 with the value CNT of the counter to generate the output signal on OC1. When the output compare preload is disabled (OC1PEN=0 for TMR14_CCM1 register), the written value will immediately affect the output compare results; If the output compare preload is enabled (TMR14_CCM1 register OC1PEN=1), the written value will affect the output compare result when an update event is generated.

16.6.11 Option register (TMR14_OPT)

Offset address: 0x50

Reset value: 0x0000

Field	Name	R/W	Description
1:0	RMPSEL	R/W	Timer Input 1 Remap Select 00: TMR14 channel 1 is connected to GPIO. Refer to the Data Manual. 01: TMR14 channel 1 is connected to RTCCLK 10: TMR14 channel 1 is connected to HSECLK/32 11: TMR14 channel 1 is connected to the main clock output (MCO); this selection is configured by MCOSEL bit of the clock configuration register RCM_CFG.
15:2	Reserved		

17 General-purpose Timer (TMR15/16/17)

17.1 Introduction

The general-purpose timer takes the time base unit as the core, and has the functions of input capture and output compare, and can be used to measure the pulse width, frequency and duty cycle, and generate the output waveform. It includes a 16-bit auto reload counter (realize count-up, count-down and center alignment count). It supports complementary output, repeat count and programmable dead-time insertion function, and is more suitable for motor control.

17.2 Main Characteristics

- (1) Timebase unit
 - Counter: 16-bit counter, count-up, count-down and center alignment count
 - Prescaler: 16-bit programmable prescaler
 - Repeat counter: 16-bit repeat counter
 - Auto reloading function
- (2) Clock source selection
 - Internal clock
 - External input (only applicable to TMR15)
 - Internal trigger (only applicable to TMR15)
- (3) Input function
 - Counting function
 - PWM input mode (only applicable to TMR15)
- (4) Output function
 - PWM output mode
 - Forced output mode
 - Single-pulse mode
 - Complementary output and dead-time insertion
- (5) Breaking function
- (6) Master/Slave mode controller of timer (only applicable to TMR15)
 - Timers can be synchronized and cascaded
 - Support multiple slave modes and synchronization signals
- (7) Interrupt output and DMA request event
 - Update event (counter overrun/underrun, counter initialization)
 - Trigger event (counter start, stop, internal/external trigger)
 - Capture/Compare event
 - Breaking signal input event

17.3 Structure Block Diagram

17.3.1 General-purpose Timer TMR15 Structure Block Diagram

Figure 51 General-purpose Timer TMR15 Structure Block Diagram

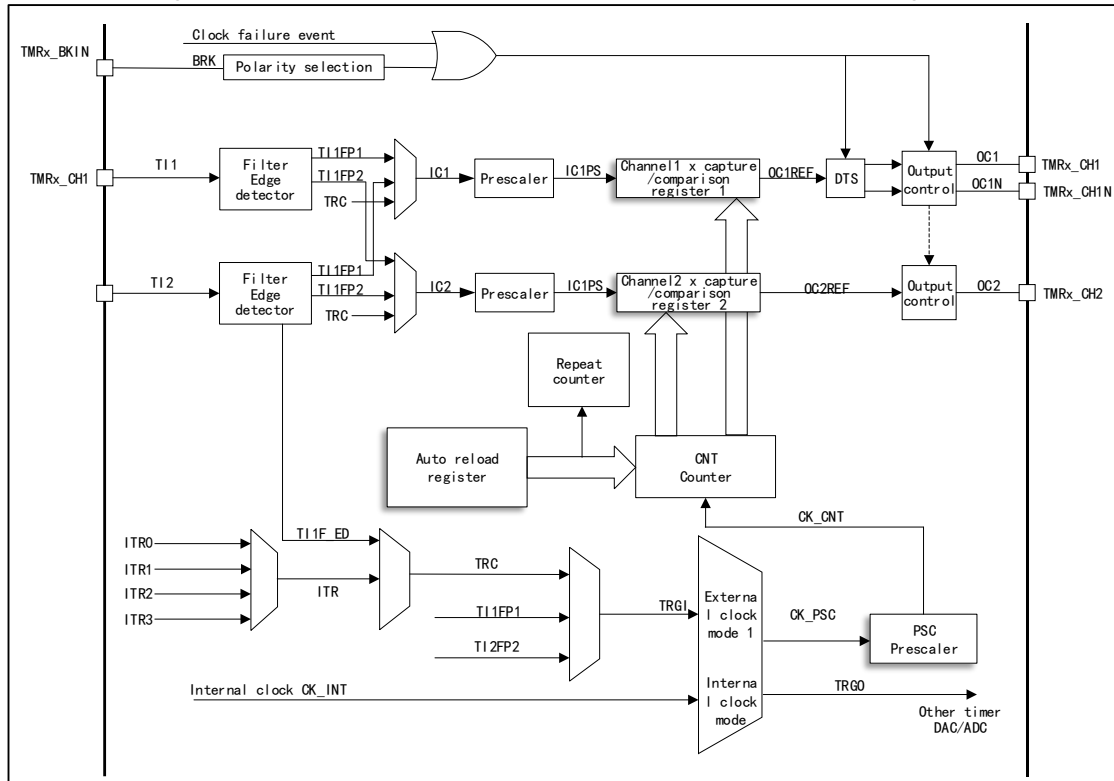

17.3.2 General-purpose Timer TMR16/17 Structure Block Diagram

Figure 52 General-purpose Timer TMR16/17 Structure Block Diagram

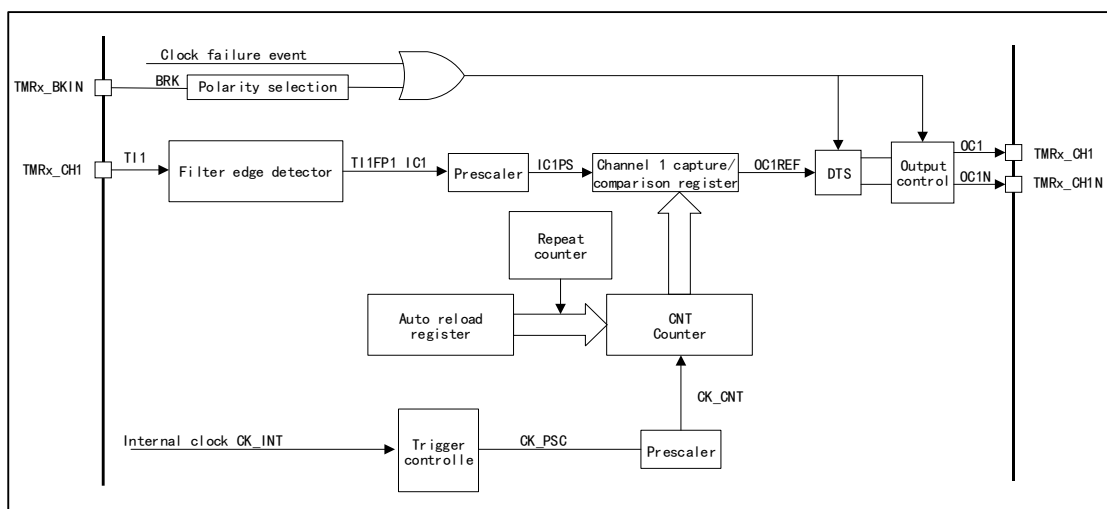

17.4 Functional Description

17.4.1 Clock Source Selection

The general-purpose timer has three clock sources

Internal clock

It is TMRx_CLK from RCM, namely the driving clock of the timer; when the slave mode controller is disabled, the clock source CK_PSC of the prescaler is driven by the internal clock CK_INT.

External clock mode 1 (TMR15)

The trigger signal generated from the input channel TI1/2/3/4 of the timer after polarity selection and filtering is connected to the slave mode controller to control the work of the counter. Besides, the pulse signal generated by the input of Channel 1 after double-edge detection of the rising edge and the falling edge is logically equal or the future signal is TI1F_ED signal, namely double-edge signal of TIF_ED. Specially the PWM input can only be input by TI1/2.

Internal trigger input (only applicable to TMR15)

The timer is set to work in slave mode, and the clock source is the output signal of other timers. At this time, the clock source has no filtering, and the synchronization or cascading between timers can be realized. The master mode timer can reset, start, stop or provide clock for the slave mode timer.

17.4.2 Timebase Unit

The time base unit in the general-purpose timer contains four registers

- Counter register (CNT) 16 bits
- Auto reload register (AUTORLD) 16 bits
- Prescaler register (PSC) 16 bits
- Repetition count register (REPCNT) 8 bits

Counter CNT

There are three counting modes for the counter in the general-purpose timer

- Count-up mode
- Count-down mode
- Center alignment mode

Count-up mode

Set to the count-up mode by CNTDIR bit of configuration control register (TMRx_CTRL1).

When the counter is in count-up mode, the counter will count up from 0; every time a pulse is generated, the counter will increase by 1 and when the value of the counter (TMRx_CNT) is equal to the value of the auto reload (TMRx_AUTORLD), the counter will start to count again from 0, a count-up overrun event will be generated, and the value of the auto reload (TMRx_AUTORLD) is written in advance.

When the counter overruns, an update event will be generated. At this time, the repeat count shadow register, the auto reload shadow register and the prescaler buffer will be updated. The update event can be disabled by UD bit of

configuration control register TMRx_CTRL1.

Figure 53 Timing Diagram when Division Factor is 1 or 2 in Count-up Mode

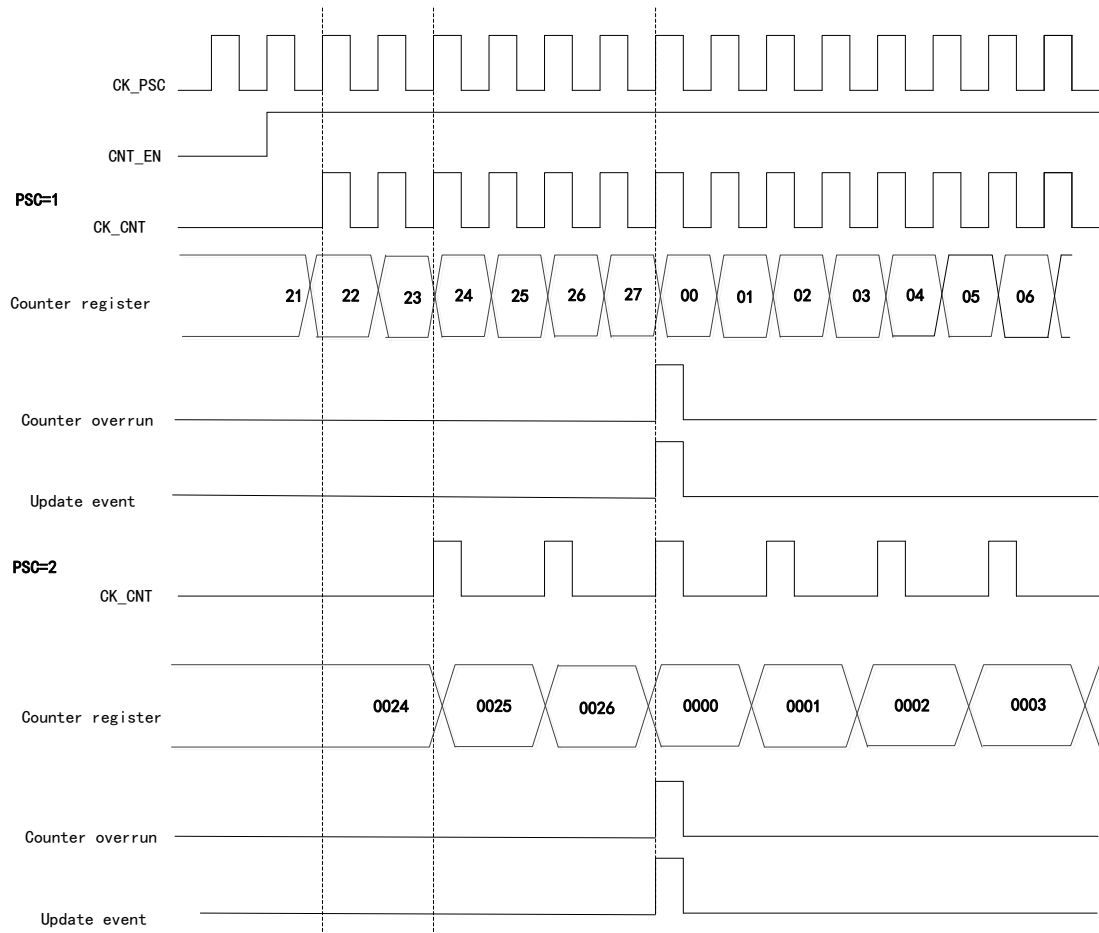

Repeat counter REPCNT

There is no repeat counter REPCNT in the basic/general-purpose timer, which means that when the overrun event or underrun event occurs in the basic/general-purpose timer, an update event will be generated directly; while in the general-purpose timer, because of the existence of the repeat counter, when an overrun/underrun event occurs to the general-purpose timer, the update event will be generated only when the value of the repeat counter is 0.

For example, if the general-purpose timer needs to generate an update event when an overrun/underrun event occurs, the value of the repeat counter should be set to 0.

If the repeat counter function is used in the count-up mode, every time the counter counts up to AUTORLD, an overrun event will occur. At this time, the value of the repeat counter will be decreased by 1, and an update event will be generated until the value of the repeat counter is 0.

That is, when N+1 (N is the value of repeat counter) overrun/underrun events occur, an update event will be generated.

The figure below shows the Timing Diagram when Setting REPCNT=2 in Count-up Mode

Figure 54 Timing Diagram when Setting REPCNT=2 in Count-up Mode

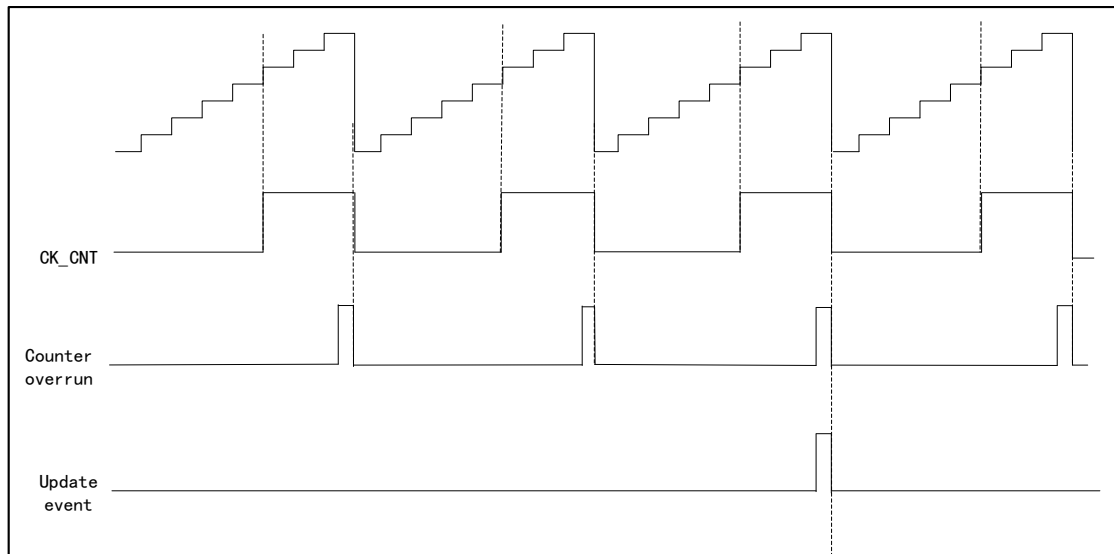

Prescaler PSC

The prescaler is 16 bits and programmable, and it can divide the clock frequency of the counter to any value between 1 and 65536 (controlled by TMRx_PSC register), and after frequency division, the clock will drive the counter CNT to count. The prescaler has a buffer, which can be changed during running.

17.4.3 Input Capture

Input capture channel

The general-purpose timer has four independent capture/compare channels, each of which is surrounded by a capture/compare register.

In the input capture, the measured signal will enter from the external pin T1/2/3/4 of the timer, first pass through the edge detector and input filter, and then into the capture channel. Each capture channel has a corresponding capture register. When the capture occurs, the value of the counter CNT will be latched in the capture register CCx. Before entering the capture register, the signal will pass through the prescaler, which is used to set how many events to capture at a time.

Input capture application

Input capture is used to capture external events, and can give the time flag to indicate the occurrence time of the event and measure the pulse jump edge events (measure the frequency or pulse width), for example, if the selected edge appears on the input pin, the TMRx_CCx register will capture the current value of the counter and the CCxIFLG bit of the state register TMRx_STS will be set to 1; if CCxIEN=1, an interrupt will be generated.

In capture mode, the timing, frequency, period and duty cycle of a waveform can be measured. In the input capture mode, the edge selection is set to rising edge detection. When the rising edge appears on the capture channel, the first capture occurs, at this time, the value of the counter CNT will be latched in the capture register CCx; at the same time, it will enter the capture interrupt, a capture will be recorded in the interrupt service program and the value will be

recorded. When the next rising edge is detected, the second capture occurs, the value of counter CNT will be latched in capture register CCx again, at this time, it will enter the capture interrupt again, the value of capture register will be read, and the cycle of this pulse signal will be obtained through capture.

17.4.4 Output Compare

There are eight modes of output compare: freeze, channel x is valid level when matching, channel x is invalid level when matching, flip, force is invalid, force is valid, PWM1 and PWM mode 2, which are configured by OCxMOD bit in TMRx_CCMx register and can control the waveform of output signal in output compare mode.

Output compare application

In the output compare mode, the position, polarity, frequency and time of the pulse generated by the timer can be controlled.

When the value of the counter is equal to that of the capture/compare register, the channel output can be set as high level, low level or flip by configuring the OCxMOD bit in TMRx_CCMx register and the CCxPOL bit in the output polarity TMRx_CCEN register.

When CCxIFLG=1 in TMRx_STS register, if CCxIEN=1 in TMRx_DIEN register, an interrupt will be generated; if CCDSEL=1 in TMRx_CTRL2 register, DMA request will be generated.

17.4.5 PWM Output Mode

PWM mode is an adjustable pulse signal output by the timer. The pulse width of the signal is determined by the value of the compare register CCx, and the cycle is determined by the value of the auto reload AUTORLD.

PWM output mode contains PWM mode 1 and PWM mode 2; PWM mode 1 and PWM mode 2 are divided into count-up, count-down and edge alignment counting; in PWM mode 1, if the value of the counter CNT is less than the value of the compare register CCx, the output level will be valid; otherwise, it will be invalid.

Set the timing diagram in PWM mode1 when CCx=5, AUTORLD=7

Figure 55 PWM1 Count-up Mode Timing Diagram

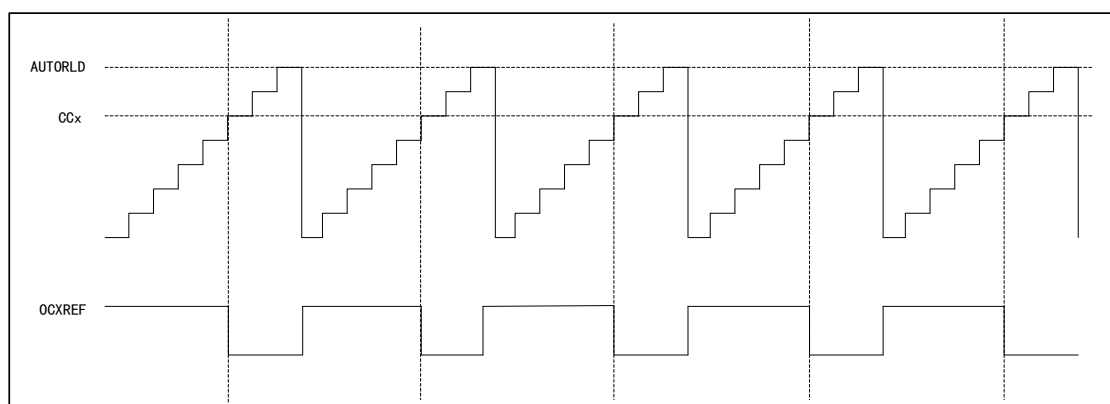

Figure 56 PWM1 Count-down Mode Timing Diagram

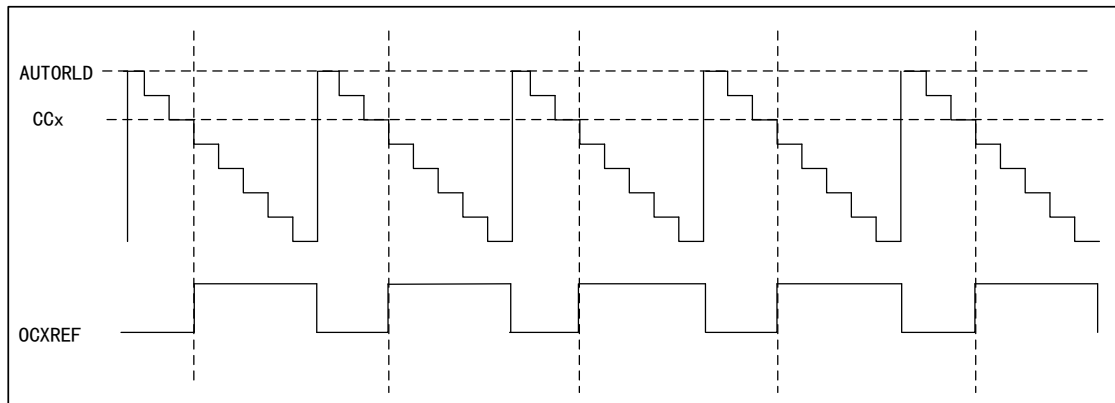
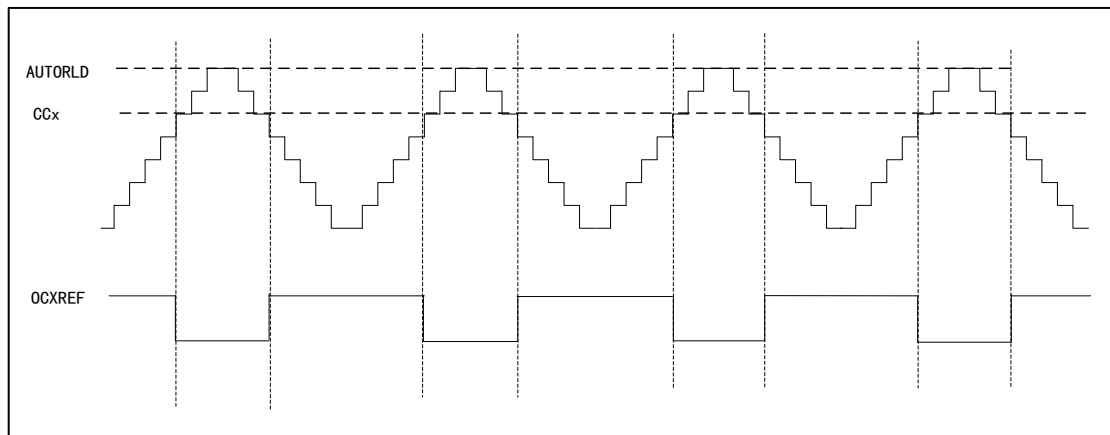

Figure 57 PWM1 Center Alignment Mode Timing Diagram



In PWM mode 2, if the value of the counter CNT is less than that of the compare register CCx, the output level will be invalid; otherwise, it will be valid.

Set the timing diagram in PWM mode 2 when CCx=5, AUTORLD=7

Figure 58 PWM2 Count-up Mode Timing Diagram

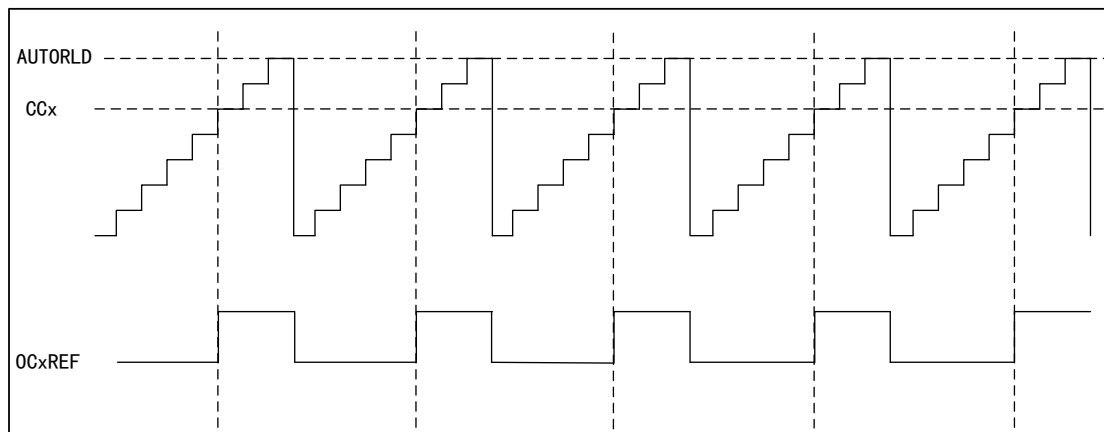

Figure 59 PWM2 Count-down Mode Timing Diagram

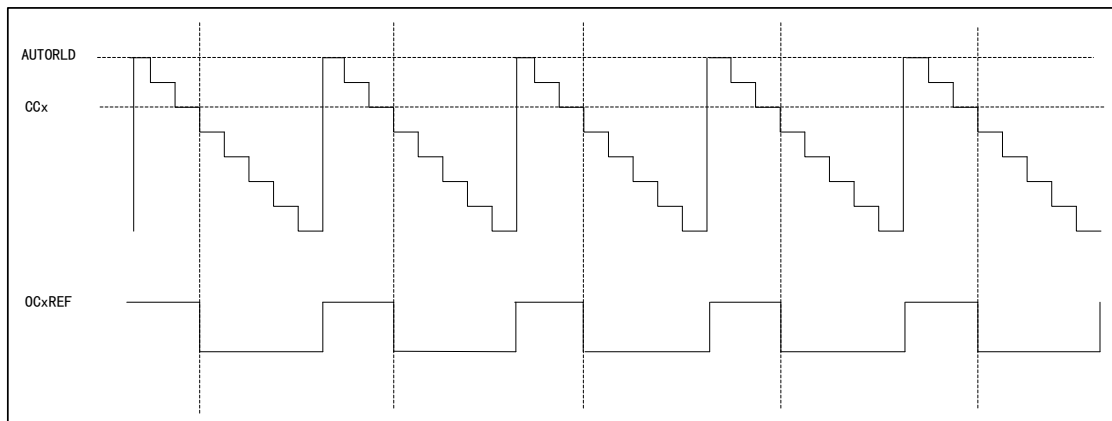
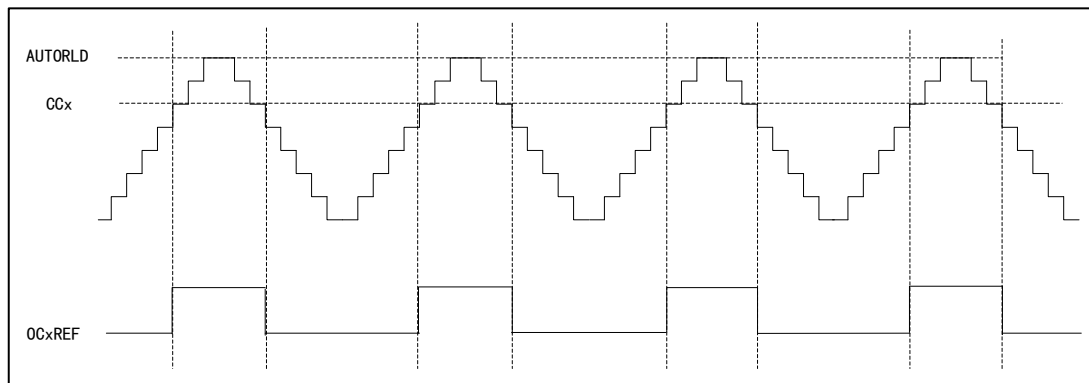

Figure 60 PWM2 Center Alignment Mode Timing Diagram



17.4.6 PWM Input Mode (only applicable to TMR15)

PWM input mode is a particular case of input capture.

In PWM input mode, as only TI1FP1 and TI1FP2 are connected to the slave mode controller, input can be performed only through the channels TMRx_CH1 and TMRx_CH2, which need to occupy the capture registers of CH1 and CH2.

In the PWM input mode, the PWM signal enters from TMRx_CH1, and the signal will be divided into two channels, one can measure the cycle and the other can measure the duty cycle. In the configuration, it is only required to set the polarity of one channel, and the other will be automatically configured with the opposite polarity.

In this mode, the slave mode controller should be configured as the reset mode (SMFSEL bit of TMRx_SMCTRL register)

Figure 61 PWM Input Mode Timing Diagram

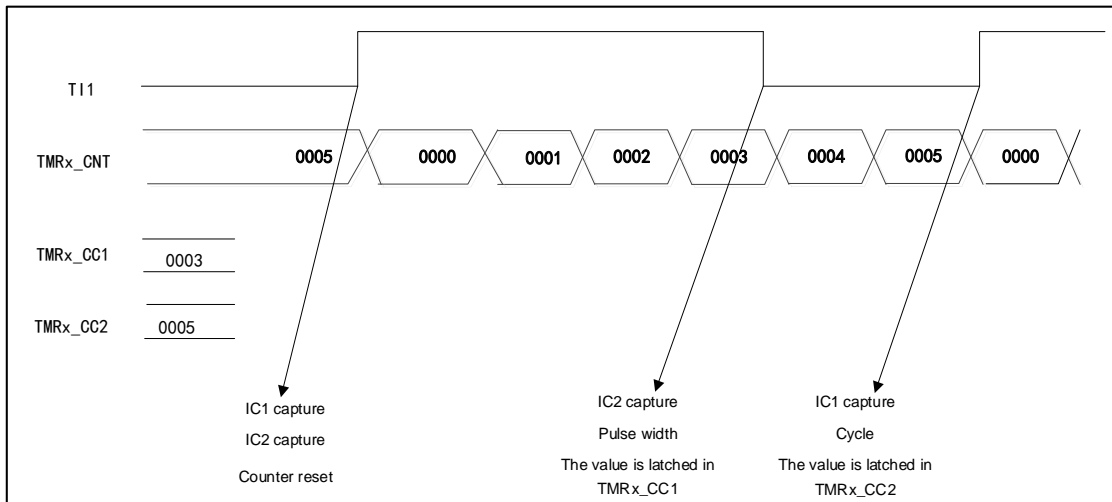

17.4.7 Single-pulse Mode

The single-pulse mode is a special case of timer compare output, and is also a special case of PWM output mode.

Set SPMEN bit of TMRx_CTRL1 register, and select the single-pulse mode. After the counter is started, a certain number of pulses will be output before the update event occurs. When an update event occurs, the counter will stop counting, and the subsequent PWM waveform output will no longer be changed.

After a certain controllable delay, a pulse with controllable pulse width is generated in single-pulse mode through the program. The delay time is defined by the value of TMRx_CCx register; in the count-up mode, the delay time is CCx and the pulse width is AUTORLD-CCx; in the count-down mode, the delay time is AUTORLD-CCx and the pulse width is CCx.

Figure 62 Single-pulse Mode Timing Diagram

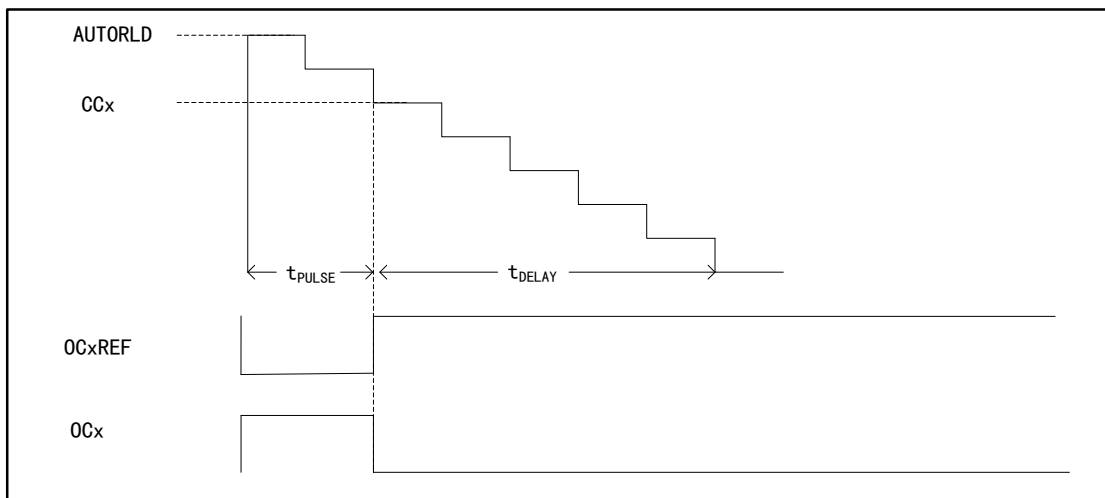

17.4.8 Impact of the Register on Output Waveform

The following registers will affect the level of the timer output waveform. For details, please refer to “Register Functional Description”.

- (1) CCxEN and CCxNEN bits in TMRx_CCEN register
 - CCxNEN=0 and CCxEN=0: The output is turned off (output disabled, invalid state)
 - CCxNEN=1 and CCxEN=1: The output is turned on (output enabled, normal output)
- (2) MOEN bit in TMRx_BDT register
 - MOEN=0: Idle mode
 - MOEN=1: Run mode
- (3) OCxOIS and OCxNOIS bits in TMRx_CTRL2 register
 - OCxOIS=0 and OCxNOIS=0: When idle (MOEN=0), the output level after the dead-time is 0
 - OCxOIS=1 and OCxNOIS=1: When idle (MOEN=0), the output level after the dead-time is 1
- (4) RMOS bit in TMRx_BDT register
 - Application environment of RMOS: In corresponding complementary channel and timer run mode (MOEN=1), the timer is not working (CCxEN=0, CCxNEN=0) or is working (CCxEN=1, CCxNEN=1)
- (5) IMOS bit in TMRx_BDT register
 - Application environment of IMOS: In corresponding complementary channel and timer are in idle mode (MOEN=0), the timer is not working (CCxEN=0, CCxNEN=0) or is working (CCxEN=1, CCxNEN=1)
- (6) CCxPOL and CCxNPOL bits of TMRx_CCEN register
 - CCxPOL=0 and CCxNPOL=0: Output polarity, high level is valid
 - CCxPOL=1 and CCxNPOL=1: Output polarity, the low level is valid

The following figure lists the register structure relationships that affect the output waveform

Figure 63 Register Structural Relationship Affecting Output Waveform

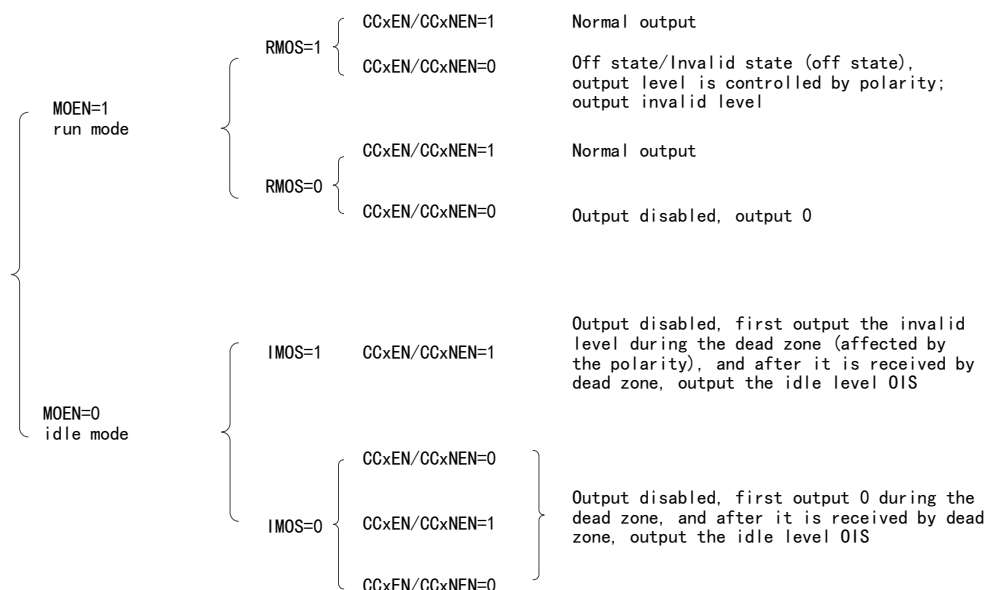

17.4.9 Breaking Function

The signal source of breaking is clock fault event and external input interface.

Besides, the BRKEN bit in TMRx_BDT register can enable the breaking function, and the BRKPOL bit can configure the polarity of breaking input signal.

When a breaking event occurs, the output pulse signal level can be modified according to the state of the relevant control bit.

Figure 64 Breaking Event Timing Diagram

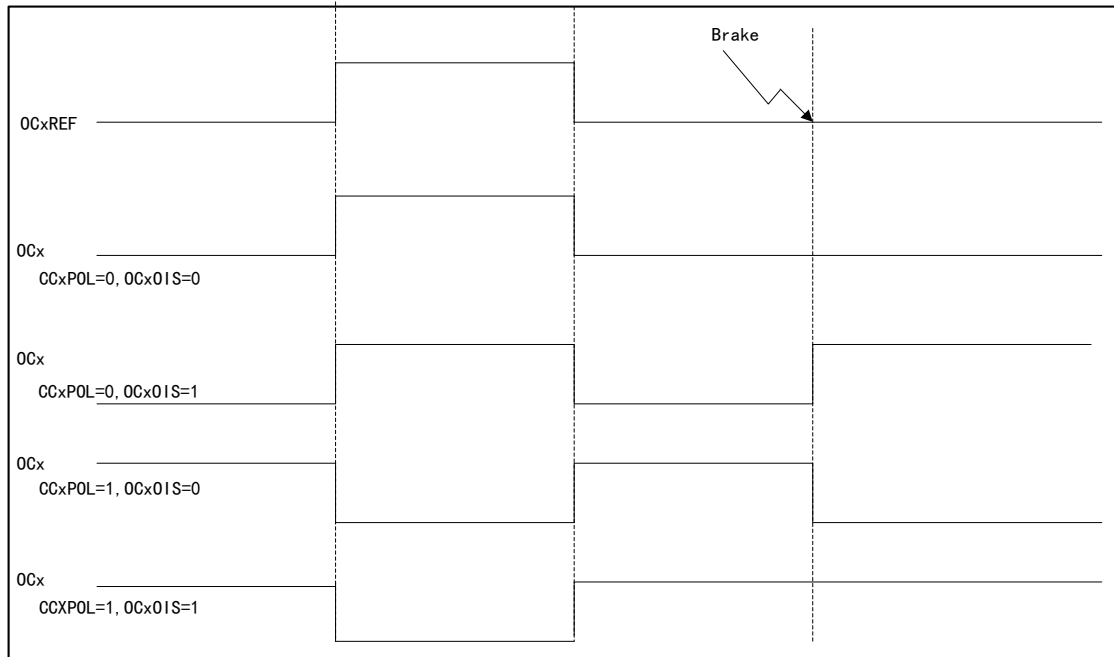

17.4.10 Complementary Output and Dead-time Insertion

Timers 15/16/17 have three groups of complementary 170chmit channels. The insertion dead time is used to generate complementary output signals to ensure that the two-way complementary signals of channels will not be valid at the same time. The dead time is set according to the output device connected to the timer and its characteristics

The duration of the dead-time can be controlled by configuring DTS bit of TMRx_BDT register

Figure 65 Complementary Output of Insertion with Dead-time

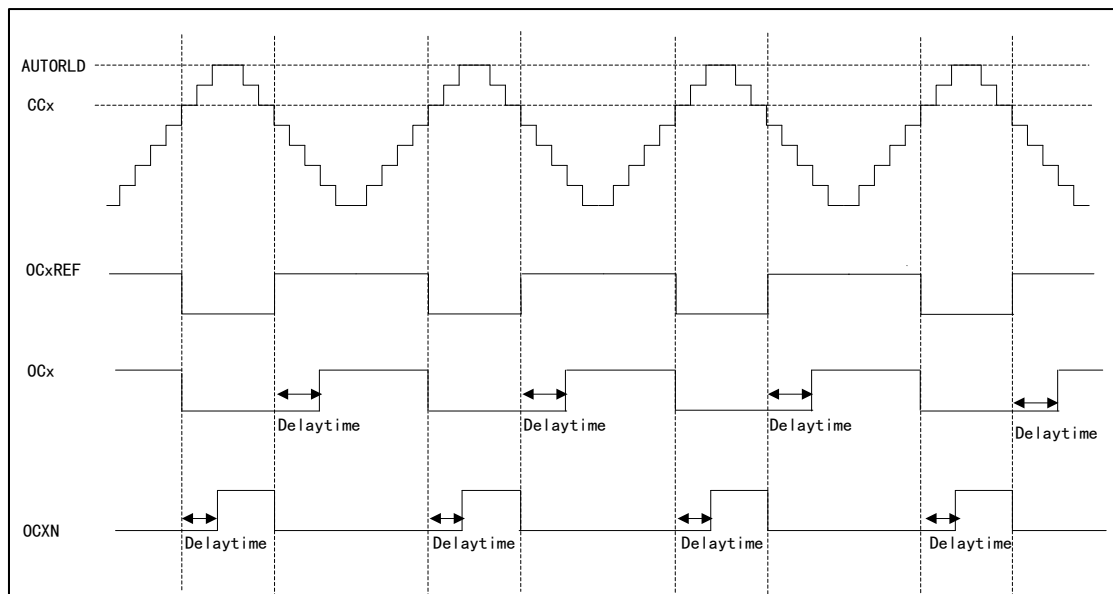

17.4.11 Forced Output Mode

In the forced output mode, the compare result is ignored, and the corresponding level is directly output according to the configuration instruction.

- CCxSEL=00 for TMRx_CCMx register, set CCx channel as output
- OCxMOD=100/101 for TMRx_CCMx register, set to force OCxREF signal to invalid/valid state

In this mode, the corresponding interrupt and DMA request will still be generated.

17.4.12 Slave Mode (only applicable to TMR15)

TMR15 timer can synchronize external trigger

- Reset mode
- Gated mode
- Trigger mode

SMFSEL bit in TMR15_SMCTRL register can be set to select the mode.

SMFSEL=100 set the reset mode, SMFSEL=101 set the gated mode, SMFSEL=110 set the trigger mode.

In the reset mode, when a trigger input event occurs, the counter and prescaler will be initialized, and the rising edge of the selected trigger input (TRGI) will reinitialize the counter and generate a signal to update the register.

In the gated mode, the enable of the counter depends on the high level of the selected input. When the trigger input is high, the clock of the counter will be started. Once the trigger input becomes low, the counter will stop (but not be reset). The start and stop of the counter are controlled.

In the trigger mode, the enable of the counter depends on the event on the selected input, the counter is started (but is not reset) at the rising edge of the trigger input, and only the start of the counter is controlled.

17.4.13 Timer Interconnection (only applicable to TMR15)

Each timer can be connected with each other to realize synchronization or cascading between timers. It is required to configure one timer in master mode and the other timer in slave mode.

When the timer is in master mode, it can reset, start, stop and provide clock source for the counter of the slave mode timer.

Figure 66 Interconnection of TMR15 and Other Timers

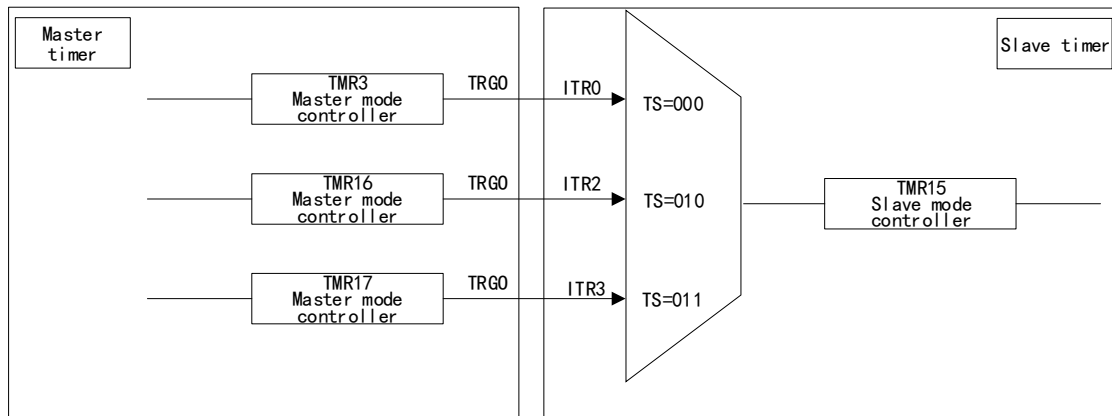

When the timers are interconnected:

- A timer can be used as the prescaler of other register
- Another register can be started by the enable signal of a timer
- Another register can be started by the update event of a timer
- Another register can be selected by the enable of a timer
- Two timers can be synchronized by an external trigger

17.4.14 Interrupt and DMA Request

The timer can generate an interrupt when an event occurs during operation

- Update event (counter overrun/underrun, counter initialization)
- Trigger event (counter start, stop, internal/external trigger)
- Capture/Compare event
- Breaking signal input event

Some internal interrupt events can generate DMA requests, and special interfaces can enable or disable DMA requests.

17.5 Register Address Mapping

In the following table, all registers of TMR15 are mapped to a 16-bit addressable (address) space.

Table 53 TMR15 Register Address Mapping

Register name	Description	Offset address
TMR15_CTRL1	Control register 1	0x00
TMR15_CTRL2	Control register 2	0x04
TMR15_SMCTRL	Slave mode control register	0x08

Register name	Description	Offset address
TMR15_DIEN	DMA/Interrupt enable register	0x0C
TMR15_STS	State register	0x10
TMR15_CEG	Control event generation register	0x14
TMR15_CCM1	Capture/Compare mode register 1	0x18
TMR15_CCEN	Capture/Compare enable register	0x20
TMR15_CNT	Counter register	0x24
TMR15_PSC	Prescaler register	0x28
TMR15_AUTORLD	Auto reload register	0x2C
TMR15_REPCNT	Repeat count register	0x30
TMR15_CC1	Channel 1 capture/compare register	0x34
TMR15_CC2	Channel 2 capture/compare register	0x38
TMR15_BDT	Break and dead-time register	0x44
TMR15_DCTRL	DMA control register	0x48
TMR15_DMADDR	DMA address register of continuous mode	0x4C

17.6 Register Functional Description

17.6.1 Control register 1 (TMR15_CTRL1)

Offset address: 0x00

Reset value: 0x0000

Field	Name	R/W	Description
0	CNTEN	R/W	Counter Enable 0: Disable 1: Enable When the timer is configured as external clock, gated mode and encoder mode, it is required to write 1 to the bit by software to start regular work; when it is configured as the trigger mode, it can be written to 1 by hardware.
1	UD	R/W	Update Disable Update event can cause AUTORLD, PSC and CCx to generate the value of update setting. 0: Update event is allowed (UEV) An update event can occur in any of the following situations: The counter overruns/underruns; Set UEG bit; Update generated by slave mode controller. 1: Update event is disabled
2	URSEL	R/W	Update Request Source Select If interrupt or DMA is enabled, the update event can generate update interrupt or DMA request. Different update request sources can be selected through this bit. 0: The counter overruns or underruns Set UEG bit Update generated by slave mode controller 1: The counter overruns or underruns
3	SPMEN	R/W	Single Pulse Mode Enable

Field	Name	R/W	Description
			When an update event is generated, the output level of the channel can be changed; in this mode, the CNTEN bit will be cleared, the counter will be stopped, and the output level of the channel will not be changed. 0: Disable 1: Enable
6:4	Reserved		
7	ARPEN	R/W	TMR15_AUTORLD Register Auto-reload Preload Enable When the buffer is disabled, the program modification TMR15_AUTORLD will immediately modify the values loaded to the counter; when the buffer is enabled, the program modification TMR15_AUTORLD will modify the values loaded to the counter in the next update event. 0: Disable 1: Enable
9:8	CLKDIV	R/W	Clock Divide Factor For the configuration of dead time and digital filter, CK_INT provides the clock, and the dead time and the clock of the digital filter can be adjusted by setting this bit. 00: $t_{DTS}=t_{CK_INT}$ 01: $t_{DTS}=2 \times t_{CK_INT}$ 10: $t_{DTS}=4 \times t_{CK_INT}$ 11: Reserved
15:10	Reserved		

17.6.2 Control register 2 (TMR15_CTRL2)

Offset address: 0x04

Reset value: 0x0000

Field	Name	R/W	Description
0	CCPEN	R/W	Capture/Compare Preloaded Enable This bit affects the change of CCxEN, CCxNEN and OCxMOD values. When preloading is disabled, the program modification will immediately affect the timer setting; When preloading is enabled, it is only updated after COMG is set, so as to affect the setting of timer; this bit only works on channels with complementary output. 0: Disable 1: Enable
1	Reserved		
2	CCUSEL	R/W	Capture/compare Control Update Select Only when the capture/compare preload is enabled (CCPEN=1), and it works only for complementary output channel. 0: It can only be updated by setting COMG bit 1: It can be updated by setting COMG bit or rising edge on TRGI
3	CCDSEL	R/W	Capture/compare DMA Select 0: Transmit DMA request of CCx when CCx event occurs 1: Transmit DMA request of CCx when an update event occurs
6:4	MMSEL	R/W	Master Mode Signal Select The signals of timers working in master mode can be used for TRGO, which affects the work of timers in slave mode and cascaded with master timer, and specifically affects the configuration of timers in slave mode. 000: Reset; the reset signal of master mode timer is used for TRGO 001: Enable; the counter enable signal of master mode timer is used for TRGO 010: Update; the update event of master mode timer is used for TRGO 011: Compare pulses; when the master mode timer captures/compares successfully (CCxIFLG=1), a pulse signal is output for TRGO 100: Compare mode 1; OC1REF is used to trigger TRGO 101: Compare mode 2; OC2REF is used to trigger TRGO

Field	Name	R/W	Description
			110: Reserved 111: Reserved
7	Reserved		
8	OC1OIS	R/W	OC1 Output Idle State Configure Only the level state after the dead time of OC1 is affected when MOEN=0 and OC1N is realized. 0: OC1=0 1: OC1=1 Note: When LOCKCFG bit in TMR15_BDT register is at the Level 1, 2 or 3, this bit cannot be modified.
9	OC1NOIS	R/W	OC1N Output Idle State Configure Only the level state after the dead time of OC1 is affected when MOEN=0 and OC1N is realized. 0: OC1N=0 1: OC1N=1 Note: When LOCKCFG bit in TMR15_BDT register is at the Level 1, 2 or 3, this bit cannot be modified.
10	OC2OIS	R/W	Configure OC2 output idle state. Refer to OC1OIS bit
15:11	Reserved		

17.6.3 Slave mode control register (TMR15_SMCTRL)

Offset address: 0x08

Reset value: 0x0000

Field	Name	R/W	Description
2:0	SMFSEL	R/W	Slave Mode Function Select 000: Disable the slave mode, the timer can be used as master mode timer to affect the work of slave mode timer; if CTRL1_CNTEN=1, the prescaler is directly driven by the internal clock. 001: Encoder mode 1; according to the level of TI1FP1, the counter counts at the edge of TI2FP2. 010: Encoder mode 2; according to the level of TI2FP2, the counter counts at the edge of TI1FP1. 011: Encoder mode 3; according to the input level of another signal, the counter counts at the edge of TI1FP1 and TI2FP2. 100: Reset mode; the slave mode timer resets the counter after receiving the rising edge signal of TRGI and generates the signal to update the register. 101: Gated mode; the slave mode timer starts the counter to work after receiving the TRGI high level signal; it stops the counter when receiving TRGI low level; when receiving TRGI high level signal again, the timer will continue to work; the counter is not reset during the whole period. 110: Trigger mode, the slave mode timer starts the counter to work after receiving the rising edge signal of TRGI. 111: External clock mode 1; select the rising edge signal of TRGI as the clock source to drive the counter to work.
3	Reserved		
6:4	TRGSEL	R/W	Trigger Input Signal Select In order to avoid false edge detection when changing the bit value, it must be changed when SMFSEL=0. 000: Internal trigger ITR0 001: Internal trigger ITR1

Field	Name	R/W	Description
			010: Internal trigger ITR2 011: Internal trigger ITR3 100: Channel 1 input edge detector TIF_ED 101: Channel 1 post-filtering timer input TI1FP1 110: Channel 2 post-filtering timer input TI2FP2 111: External trigger input (ETRF)
7	MSMEN	R/W	Master/slave Mode Enable 0: Invalid 1: Enable the master/slave mode
15:8	Reserved		

Table 54 TMR15 Internal Trigger Connection

Slave timer	ITR0 (TS=000)	ITR1 (TS=001)	ITR2 (TS=010)	ITR3 (TS=011)
TMR15	TMR2	TMR3	TMR16	TMR17

17.6.4 DMA/Interrupt enable register (TMR15_DIEN)

Offset address: 0x0C

Reset value: 0x0000

Field	Name	R/W	Description
0	UIEN	R/W	Update interrupt Enable 0: Disable 1: Enable
1	CC1IEN	R/W	Capture/Compare Channel1 Interrupt Enable 0: Disable 1: Enable
2	CC2IEN	R/W	Capture/Compare Channel2 Interrupt Enable 0: Disable 1: Enable
4:3	Reserved		
5	COMIEN	R/W	COM Interrupt Enable 0: Disable 1: Enable
6	TRGIEN	R/W	Trigger interrupt Enable 0: Disable 1: Enable
7	BRKIEN	R/W	Break interrupt Enable 0: Disable 1: Enable
8	UDIEN	R/W	Update DMA Request Enable 0: Disable 1: Enable
9	CC1DEN	R/W	Capture/Compare Channel1 DMA Request Enable 0: Disable 1: Enable

Field	Name	R/W	Description
10	CC2DEN	R/W	Capture/Compare Channel2 DMA Request Enable 0: Disable 1: Enable
13:11	Reserved		
14	TRGDEN	R/W	Trigger DMA Request Enable 0: Disable 1: Enable
15	Reserved		

17.6.5 State register (TMR15_STS)

Offset address: 0x10

Reset value: 0x0000

Field	Name	R/W	Description
0	UIFLG	RC_W0	Update Event Interrupt Generate Flag 0: Update event interrupt does not occur 1: Update event interrupt occurs When the counter value is reloaded or reinitialized, an update event will be generated. The bit is set to 1 by hardware and cleared by software; update events are generated in the following situations: (1) UD=0 on TMR15_CTRL1 register, and when the value of the repeat counter overruns/underruns, an update event will be generated; (2) URSSEL=0 and UD=0 on TMR15_CTRL1 register, configure UEG = 1 on TMR15_CEG register to generate an update event, and the counter needs to be initialized by software; (3) URSSEL=0 and UD=0 on TMR15_CTRL1 register, generate an update event when the counter is initialized by trigger event.
1	CC1IFLG	RC_W0	Capture/Compare Channel1 Interrupt Flag When the capture/compare channel 1 is configured as output: 0: No matching occurred 1: The value of TMR15_CNT matches the value of TMR15_CC1 When the capture/compare channel 1 is configured as input: 0: Input capture did not occur 1: Input capture occurred It is set to 1 by hardware when capture event occurs, and can be cleared by software or by reading TMR15_CC1 register.
2	CC2IFLG	RC_W0	Capture/Compare Channel2 Interrupt Flag Refer to STS_CC1IFLG
4:3	Reserved		
5	COMIFLG	RC_W0	COM Event Interrupt Generate Flag 0: COM event does not occur 1: COM interrupt waits for response After COM event is generated, this bit is set to 1 by hardware and cleared by software.
6	TRGIFLG	RC_W0	Trigger Event Interrupt Generate Flag 0: Trigger event interrupt did not occur 1: Trigger event interrupt occurred After Trigger event is generated, this bit is set to 1 by hardware and cleared by software.

Field	Name	R/W	Description
7	BRKIFLG	RC_W0	Break Event Interrupt Generate Flag 0: Break event does not occur 1: Break event occurs When break input is valid, this bit is set to 1 by hardware; when break input is invalid, this bit can be cleared by software.
8	Reserved		
9	CC1RCFLG	RC_W0	Capture/compare Channel1 Repetition Capture Flag 0: Repeat capture does not occur 1: Repeat capture occurs The value of the counter is captured in TMR15_CC1 register, and CC1IFLG=1; only when the channel is configured as input capture, can this bit be set to 1 by hardware and cleared by software.
10	CC2RCFLG	RC_W0	Capture/compare Channel2 Repetition Capture Flag Refer to STS_CC1RCFLG
15:11	Reserved		

17.6.6 Control event generation register (TMR15_CEG)

Offset address: 0x14

Reset value: 0x0000

Field	Name	R/W	Description
0	UEG	W	Update Event Generate 0: Invalid 1: Initialize the counter and generate the update event This bit is set to 1 by software, and cleared by hardware. Note: When an update event is generated, the counter of the prescaler will be cleared, but the prescaler factor remains unchanged. In count-down mode, the counter will read the value of TMR15_AUTORLD; in center alignment mode or count-up mode, the counter will be cleared.
1	CC1EG	W	Capture/Compare Channel1 Event Generation 0: Invalid 1: Capture/Compare event is generated This bit is set to 1 by software and cleared automatically by hardware. If Channel 1 is in output mode: When CC1IFLG=1, if CC1IEN and CC1DEN bits are set, the corresponding interrupt and DMA request will be generated. If Channel 1 is in input mode: The value of the capture counter is stored in TMR15_CC1 register; configure CC1IFLG=1, and if CC1IEN and CC1DEN bits are also set, the corresponding interrupt and DMA request will be generated; at this time, if CC1IFLG=1, it is required to configure CC1RCFLG=1.
2	CC2EG	W	Capture/Compare Channel2 Event Generation Refer to CC1EG description
4:3	Reserved		
5	COMG	W	Capture/Compare Control Update Event Generate 0: Invalid 1: Capture/Compare update event is generated This bit is set to 1 by software and cleared automatically by hardware. Note: COMG bit is valid only in complementary output channel.
6	TEG	W	Trigger Event Generate 0: Invalid 1: Trigger event is generated This bit is set to 1 by software and cleared automatically by hardware.
7	BEG	W	Break Event Generate 0: Invalid

Field	Name	R/W	Description
			1: Break event is generated This bit is set to 1 by software and cleared automatically by hardware.
15:8			Reserved

17.6.7 Capture/Compare mode register 1 (TMR15_CCM1)

Offset address: 0x18

Reset value: 0x0000

The timer can be configured as input (capture mode) or output (compare mode) by CCxSEL bit. The functions of other bits of the register are different in input and output modes, and the functions of the same bit are different in output mode and input mode. The OCxx in the register describes the function of the channel in the output mode, and the ICxx in the register describes the function of the channel in the input mode.

Output compare mode:

Field	Name	R/W	Description
1:0	CC1SEL	R/W	Capture/Compare Channel 1 Select This bit defines the input/output direction and the selected input pin. 00: CC1 channel is output 01: CC1 channel is input, and IC1 is mapped on TI1 10: CC1 channel is input, and IC1 is mapped on TI2 11: CC1 channel is input, and IC1 is mapped on TRC, and only works in internal trigger input Note: This bit can be written only when the channel is closed (TMR15_CCEN register CC1EN=0).
2	OC1FEN	R/W	Output Compare Channel1 Fast Enable 0: Disable 1: Enable This bit is used to improve the response of the capture/compare output to the trigger input event.
3	OC1PEN	R/W	Output Compare Channel1 Preload Enable 0: Preloading function is disabled; write the value of TMR15_CC1 register through the program and it will work immediately. 1: Preloading function is enabled; write the value of TMR15_CC1 register through the program and it will work after an update event is generated. Note: When the protection level is 3 and the channel is configured as output, this bit cannot be modified. When the preload register is uncertain, PWM mode can be used only in single pulse mode (SPMEN=1); otherwise, the following output compare result is uncertain.
6:4	OC1MOD	R/W	Output Compare Channel1 Mode Configure 000: Freeze The output compare has no effect on OC1REF 001: The output value is high when matching. When the value of counter CNT matches the value CCx of capture/compare register, OC1REF will be forced to be at high level 010: The output value is low when matching. When the value of the counter matches the value of the capture/compare register, OC1REF will be forced to be at low level 011: Output flaps when matching. When the value of the counter matches the value of the capture/compare register, flap the level of OC1REF 100: The output is forced to be low Force OC1REF to be at low level 101: The output is forced to be high. Force OC1REF to be at high level 110: PWM mode 1 (set to high when the counter value < output compare value; otherwise, set to low) 111: PWM mode 2 (set to high when the counter value > output compare value; otherwise, set to low) Note: When the protection level is 3 and the channel is configured as output, this bit cannot be modified. In PWM modes 1 and 2, the OC1REF level changes when the compare result changes or when the output compare mode changes from freeze mode to PWM mode.

Field	Name	R/W	Description
7	Reserved		
9:8	CC2SEL	R/W	Capture/Compare Channel2 Select This bit defines the input/output direction and the selected input pin. 00: CC2 channel is output 01: CC2 channel is input, and IC2 is mapped on TI2 10: CC2 channel is input, and IC2 is mapped on TI1 11: CC2 channel is input, and IC2 is mapped on TRC, and only works in internal trigger input Note: This bit can be written only when the channel is closed (TMR15_CCEN register CC2EN=0).
10	OC2FEN	R/W	Output Compare Channel2 Preload Enable
11	OC2PEN	R/W	Output Compare Channel2 Buffer Enable
14:12	OC2MOD	R/W	Output Compare Channel1 Mode
15	Reserved		

Input capture mode:

Field	Name	R/W	Description
1:0	CC1SEL	R/W	Capture/Compare Channel 1 Select 00: CC1 channel is output 01: CC1 channel is input, and IC1 is mapped on TI1 10: CC1 channel is input, and IC1 is mapped on TI2 11: CC1 channel is input, and IC1 is mapped on TRC, and only works in internal trigger input Note: This bit can be written only when the channel is closed (TMR15_CCEN bit CC1EN=0).
3:2	IC1PSC	R/W	Input Capture Channel 1 Prescaler Configure 00: PSC=1 01: PSC=2 10: PSC=4 11: PSC=8 PSC is prescaled factor, which triggers capture once every PSC events.
7:4	IC1F	R/W	Input Capture Channel 1 Filter Configure 0000: Filter disabled, sampling by f_{DTS} 0001: DIV=1, N=2 0010: DIV=1, N=4 0011: DIV=1, N=8 0100: DIV=2, N=6 0101: DIV=2, N=8 0110: DIV=4, N=6 0111: DIV=4, N=8 1000: DIV=8, N=6 1001: DIV=8, N=8 1010: DIV=16, N=5 1011: DIV=16, N=6 1100: DIV=16, N=8 1101: DIV=32, N=5 1110: DIV=32, N=6 1111: DIV=32, N=8 Sampling frequency=timer clock frequency/DIV; the filter length=N, indicating that a jump is generated by every N events.
9:8	CC2SEL	R/W	Capture/Compare Channel 2 Select 00: CC2 channel is output 01: CC2 channel is input, and IC2 is mapped on TI1 10: CC2 channel is input, and IC2 is mapped on TI2 11: CC2 channel is input, and IC2 is mapped on TRC, and only works in

Field	Name	R/W	Description
			internal trigger input Note: This bit can be written only when the channel is closed (TMR15_CCEN register CC2EN=0).
11:10	IC2PSC	R/W	Input Capture Channel 2 Perscaler Configure
15:12	IC2F	R/W	Input Capture Channel 2 Filter Configure

17.6.8 Capture/Compare enable register (TMR15_CCEN)

Offset address: 0x20

Reset value: 0x0000

Field	Name	R/W	Description
0	CC1EN	R/W	<p>Capture/Compare Channel1 Output Enable</p> <p>When the capture/compare channel 1 is configured as output: 0: Output is disabled 1: Output is enabled</p> <p>When the capture/compare channel 1 is configured as input: This bit determines whether the value CNT of the counter can capture and enter TMR15_CC1 register 0: Capture is disabled 1: Capture is enabled</p>
1	CC1POL	R/W	<p>Capture/Compare Channel1 Output Polarity Configure</p> <p>When CC1 channel is configured as output: 0: OC1 high level is valid 1: OC1 low level is valid</p> <p>When CC1 channel is configured as input: CC1POL/CC1NPOL controls the polarity of the triggered or captured signals TI1FP1 and TI2FP1 at the same time 00: Non-phase-inverting/rising edge: TIxFP1 is not reversed phase (triggered in gated and encoder mode), and is captured at the rising edge of TIxFP1 (reset trigger, capture, external clock and trigger mode). 01: Inverted phase/Falling edge: TIxFP1 is reversed phase (triggered in gated and encoder mode), and is captured at the rising edge of TIxFP1 (reset trigger, capture, external clock and trigger mode). 10: Reserved 11: Non-phase-inverting/Rising and falling edges: TIxFP1 is not reversed phase (triggered in gated mode, cannot be used in encoder mode), and is captured at the rising edge of TIxFP1 (reset trigger, capture, external clock and trigger mode).</p>
2	CC1NEN	R/W	<p>Capture/Compare Channel1 Complementary Output Enable</p> <p>0: Disable 1: Enable</p>
3	CC1NPOL	R/W	<p>Capture/Compare Channel1 Complementary Output Polarity</p> <p>0: OC1N high level is valid 1: OC1N low level is valid</p> <p>Note: When the protection level is 2 or 3, this bit cannot be modified</p>
4	CC2EN	R/W	<p>Capture/Compare Channel2 Output Enable</p> <p>Refer to CCEN_CC1EN</p>
5	CC2POL	R/W	<p>Capture/Compare Channel2 Output Polarity Configure</p> <p>Refer to CCEN_CC1POL</p>
6	Reserved		

Field	Name	R/W	Description
7	CC2NPOL	R/W	Capture/Compare Channel2 Complementary Output Polarity Configure Refer to CCEN_CC1NPOL
15:8	Reserved		

17.6.9 Counter register (TMR15_CNT)

Offset address: 0x24

Reset value: 0x0000

Field	Name	R/W	Description
15:0	CNT	R/W	Counter Value

17.6.10 Prescaler register (TMR15_PSC)

Offset address: 0x28

Reset value: 0x0000

Field	Name	R/W	Description
15:0	PSC	R/W	Prescaler Value Clock frequency of counter (CK_CNT) = $f_{CK_PSC} / (PSC + 1)$

17.6.11 Auto reload register (TMR15_AUTORLD)

Offset address: 0x2C

Reset value: 0xFFFF

Field	Name	R/W	Description
15:0	AUTORLD	R/W	Auto Reload Value When the value of auto reload is empty, the counter will not count.

17.6.12 Repeat counter register (TMR15_REPCNT)

Offset address: 0x30

Reset value: 0x0000

Field	Name	R/W	Description
7:0	REPCNT	R/W	Repetition Counter Value When the count value of the repeat counter is reduced to 0, an update event will be generated, and the counter will start counting again from the REPCNT value; the new value newly written to this register is valid only when an update event occurs in next cycle.
15:8	Reserved		

17.6.13 Channel 1 capture/compare register (TMR15_CC1)

Offset address: 0x34

Reset value: 0x0000

Field	Name	R/W	Description
15:0	CC1	R/W	Capture/Compare Channel 1 Value When the capture/compare channel 1 is configured as input mode: CC1 contains the counter value transmitted by the last input capture channel 1 event. When the capture/compare channel 1 is configured as output mode: CC1 contains the current load capture/compare register value

Field	Name	R/W	Description
			Compare the value CC1 of the capture and compare channel 1 with the value CNT of the counter to generate the output signal on OC1. When the output compare preload is disabled (OC1PEN=0 for TMR15_CCM1 register), the written value will immediately affect the output compare results; If the output compare preload is enabled (TMR15_CCM1 register OC1PEN=1), the written value will affect the output compare result when an update event is generated.

17.6.14 Channel 2 capture/compare register (TMR15_CC2)

Offset address: 0x38

Reset value: 0x0000

Field	Name	R/W	Description
15:0	CC2	R/W	Capture/Compare Channel 2 Value Refer to TMR15_CC1

17.6.15 Break and dead-time register (TMR15_BDT)

Offset address: 0x44

Reset value: 0x0000

Note: According to the lock setting, AOEN, BRKPOL, BRKEN, IMOS, RMOS and DTS[7:0] bits all can be write-protected, and it is necessary to configure them when writing to TMR15_BDT register for the first time.

Field	Name	R/W	Description
7:0	DTS	R/W	Dead Time Setup DT is the dead duration, and the relationship between DT and register DTS is as follows: DTS[7:5]=0xx=>DT=DTS[7:0]×T _{DTS} , T _{DTS} =T _{DTS} ; DTS[7:5]=10x=>DT= (64+DTS[5:0]) ×T _{DTS} , T _{DTS} =2×T _{DTS} ; DTS[7:5]=110=>DT= (32+DTS[4:0]) ×T _{DTS} , T _{DTS} =8×T _{DTS} ; DTS[7:5]=111=>DT= (32+DTS[4:0]) ×T _{DTS} , T _{DTS} =16×T _{DTS} ; For example: assuming T _{DTS} =125ns (8MHZ), the dead time setting is as follows: If the step time is 125ns, the dead time can be set from 0 to 15875ns; If the step time is 250ns, the dead time can be set from 16us to 31750ns; If the step time is 1μs, the dead time can be set from 32μs to 63μs; If the step time is 2μs, the dead time can be set from 64μs to 126μs. Note: Once LOCK level (LOCKCFG bit in TMR15_BDT register) is set to 1, 2 or 3, these bits cannot be modified.
9:8	LOCKCFG	R/W	Lock Write Protection Mode Configure 00: Without Lock write protection level; the register can be written directly 01: Lock write protection level 1 It cannot be written to DTS, BRKEN, BRKPOL and AOEN bits of TMR15_BDT, and OCxOIS and OCxNOIS bits of TMR15_CTRL2 register. 02: Lock write protection level 2 It is not allowed to write to all bits with protection level 1 and write to the CCxPOL and OCxNPOL bits in TMR15_CCEN register and the RMOS and IMOS bits in TMR15_BDT register. 11: Lock write protection level 3 It is not allowed to write to all bits with protection level 2, and write to the OCxMOD and OCxPEN bits of TMR15_CCMx register. Note: After system reset, the lock write protect bit can only be written once.
10	IMOS	R/W	Idle Mode Off-state Configure Idle mode means MOEN=0; closed means CcxEN=0; this bit describes the impact of different values for this bit on the output waveform when MOEN=0 and CcxEN changes from 0 to 1. 0: OCx/OCxN output is disabled

Field	Name	R/W	Description
			1: If CCxEN=1, the invalid level is output during the dead time (the specific level value is affected by the polarity configuration), and the idle level is output after the dead time
11	RMOS	R/W	Run Mode Off-state Configure Run mode means MOEN=1; closed means CcxEN=0; this bit describes the impact of different values for this bit on the output waveform when MOEN=1 and CcxEN changes from 0 to 1. 0: OCx/OCxN output is disabled 1: OCx/OCxN first output invalid level (the specific level value is affected by the polarity configuration)
12	BRKEN	R/W	Break Function Enable 0: Disable 1: Enable Note: When the protection level is 1, this bit cannot be modified.
13	BRKPOL	R/W	Break Polarity Configure 0: The break input BRK is valid at low level 1: The break input BRK is valid at high level Note: When the protection level is 1, this bit cannot be modified. Writing to this bit requires an APB clock delay before it can be used.
14	AOEN	R/W	Automatic Output Enable 0: MOEN can only be set to 1 by software 1: MOEN can be set to 1 by software or be automatically set to 1 in next update event (breaking input is ineffective) Note: When the protection level is 1, this bit cannot be modified.
15	MOEN	R/W	PWM Main Output Enable 0: Disable the output of OCx and OCxN or force the output of idle state 1: When CCxEN and CCxNEN bits of the TMR15_CCEN register are set, turn on OCx and OCxN output When the break input is valid, it is cleared by hardware asynchronously. Note: Setting to 1 by software or setting to 1 automatically depends on AOEN bit of the TMR15_BDT register.

17.6.16 DMA control register (TMR15_DCTRL)

Offset address: 0x48

Reset value: 0x0000

Field	Name	R/W	Description
4:0	DBADDR	R/W	DMA Base Address Setup These bits define the base address of DMA in continuous mode (when reading or writing TMR15_DMA register), and DBADDR is defined as the offset from the address of TMR15_CTRL1 register: 00000: TMR15_CTRL1 00001: TMR15_CTRL2 00010: TMR15_SMCTRL
7:5	Reserved		
12:8	DBLEN	R/W	DMA Burst Transfer Length Setup These bits define the transfer length and transfer times of DMA in continuous mode. The data transferred can be 16 bits and 8 bits. When reading/writing TMR15_DMADDR register, the timer will conduct a continuous transmission; 00000: Transmission for 1 time 00001: Transmission for 2 times 00010: Transmission for 3 times 10001: Transmission for 18 times The transmission address formula is as follows:

Field	Name	R/W	Description
			<p>Transmission address=TMR15_CTRL1 address (slave address) +DBADDR+DMA index; DMA index=DBLEN</p> <p>For example: DBLEN=7, DBADDR=TMR15_CTRL1 (slave address) means the address of the data to be transmitted, while the address +DBADDR+7 of TMR15_CTRL1 means the address of the data to be written/read,</p> <p>Data transmission will occur to: TMR15_CTRL1 address + seven registers starting from DBADDR.</p> <p>The data transmission will change according to different DMA data length:</p> <p>When the transmission data is set to 16 bits, the data will be transmitted to seven registers</p> <p>When the transmission data is set to 8 bits, the data of the first register is the MSB bit of the first data, the data of the second register is the LSB bit of the first data, and the data will still be transmitted to seven registers.</p>
15:13			Reserved

17.6.17 DMA address register of continuous mode (TMR15_DMADDR)

Offset address: 0x4C

Reset value: 0x0000

Field	Name	R/W	Description
15:0	DMADDR	R/W	<p>DMA Register for Burst Transfer</p> <p>Read or write operation access of TMR15_DMADDR register may lead to access operation of the register in the following address:</p> <p>TMR15_CTRL1 address + (DBADDR+DMA index) ×4</p> <p>Wherein:</p> <p>“TMR15_CTRL1 address” is the address of control register 1 (TMR15_CTRL1);</p> <p>“DBADDR” is the base address defined in TMR15_DCTRL register;</p> <p>“DMA index” is the offset automatically controlled by DMA, and it depends on DBLEN defined in TMR15_DCTRL register.</p>

17.7 TMR16 and TMR17 Register Address Mapping

In the following table, all registers of TMR16 and TMR17 are mapped to a 16-bit addressable (address) space.

Table 55 TMR16 and TMR17 Register Address Mapping

Register name	Description	Offset address
TMRx_CTRL1	Control register 1	0x00
TMRx_CTRL2	Control register 2	0x04
TMRx_DIEN	DMA/Interrupt enable register	0x0C
TMRx_STS	State register	0x10
TMRx_CEG	Control event generation register	0x14
TMRx_CCM1	Capture/Compare mode register 1	0x18
TMRx_CCEN	Capture/Compare enable register	0x20
TMRx_CNT	Counter register	0x24

Register name	Description	Offset address
TMRx_PSC	Prescaler register	0x28
TMRx_AUTORLD	Auto reload register	0x2C
TMRx_REPCNT	Repeat count register	0x30
TMRx_CC1	Channel 1 capture/compare register	0x34
TMRx_BDT	Break and dead-time register	0x44
TMRx_DCTRL	DMA control register	0x48
TMRx_DMADDR	DMA address register of continuous mode	0x4C

17.8 TMR16 and TMR17 Register Functional Description

17.8.1 Control register 1 (TMRx_CTRL1)

Offset address: 0x00

Reset value: 0x0000

Field	Name	R/W	Description
0	CNTEN	R/W	Counter Enable 0: Disable 1: Enable When the timer is configured as external clock, gated mode and encoder mode, it is required to write 1 to the bit by software to start regular work; when it is configured as the trigger mode, it can be written to 1 by hardware.
1	UD	R/W	Update Disable Update event can cause AUTORLD, PSC and CCx to generate the value of update setting. 0: Update event is allowed (UEV) An update event can occur in any of the following situations: The counter overruns/underruns; Set UEG bit; Update generated by slave mode controller. 1: Update event is disabled
2	URSSEL	R/W	Update Request Source Select If interrupt or DMA is enabled, the update event can generate update interrupt or DMA request. Different update request sources can be selected through this bit. 0: The counter overruns or underruns Set UEG bit Update generated by slave mode controller 1: The counter overruns or underruns
3	SPMEN	R/W	Single Pulse Mode Enable When an update event is generated, the output level of the channel can be changed; in this mode, the CNTEN bit will be cleared, the counter will be stopped, and the output level of the channel will not be changed. 0: Disable 1: Enable

Field	Name	R/W	Description
6:4	Reserved		
7	ARPEN	R/W	<p>TMRx_AUTORLD Register Auto-reload Preload Enable</p> <p>When the buffer is disabled, the program modification TMRx_AUTORLD will immediately modify the values loaded to the counter; when the buffer is enabled, the program modification TMRx_AUTORLD will modify the values loaded to the counter in the next update event.</p> <p>0: Disable</p> <p>1: Enable</p>
9:8	CLKDIV	R/W	<p>Clock Divide Factor</p> <p>For the configuration of dead time and digital filter, CK_INT provides the clock, and the dead time and the clock of the digital filter can be adjusted by setting this bit.</p> <p>00: $t_{DTS}=t_{CK_INT}$</p> <p>01: $t_{DTS}=2 \times t_{CK_INT}$</p> <p>10: $t_{DTS}=4 \times t_{CK_INT}$</p> <p>11: Reserved</p>
15:10	Reserved		

17.8.2 Control register 2 (TMRx_CTRL2)

Offset address: 0x04

Reset value: 0x0000

Field	Name	R/W	Description
0	CCPEN	R/W	<p>Capture/Compare Preloaded Enable</p> <p>This bit affects the change of CCxEN, CCxNEN and OCxMOD values. When preloading is disabled, the program modification will immediately affect the timer setting; When preloading is enabled, it is only updated after COMG is set, so as to affect the setting of timer; this bit only works on channels with complementary output.</p> <p>0: Disable</p> <p>1: Enable</p>
1	Reserved		
2	CCUSEL	R/W	<p>Capture/compare Control Update Select</p> <p>Only when the capture/compare preload is enabled (CCPEN=1), and it works only for complementary output channel.</p> <p>0: It can only be updated by setting COMG bit</p> <p>1: It can be updated by setting COMG bit or rising edge on TRGI</p>
3	CCDSEL	R/W	<p>Capture/compare DMA Select</p> <p>0: Transmit DMA request of CCx when CCx event occurs</p> <p>1: Transmit DMA request of CCx when an update event occurs</p>
7:4	Reserved		
8	OC1OIS	R/W	<p>OC1 Output Idle State Configure</p> <p>Only the level state after the dead time of OC1 is affected when MOEN=0 and OC1N is realized.</p> <p>0: OC1=0</p> <p>1: OC1=1</p> <p>Note: When LOCKCFG bit in TMRx_BDT register is at the Level 1, 2 or 3, this bit cannot be modified.</p>

Field	Name	R/W	Description
9	OC1NOIS	R/W	OC1N Output Idle State Configure Only the level state after the dead time of OC1 is affected when MOEN=0 and OC1N is realized. 0: OC1N=0 1: OC1N=1 Note: When LOCKCFG bit in TMRx_BDT register is at the Level 1, 2 or 3, this bit cannot be modified.
15:10	Reserved		

17.8.3 DMA/Interrupt enable register (TMRx_DIEN)

Offset address: 0x0C

Reset value: 0x0000

Field	Name	R/W	Description
0	UIEN	R/W	Update interrupt Enable 0: Disable 1: Enable
1	CC1IEN	R/W	Capture/Compare Channel1 Interrupt Enable 0: Disable 1: Enable
4:2	Reserved		
5	COMIEN	R/W	COM Interrupt Enable 0: Disable 1: Enable
6	Reserved		
7	BRKIEN	R/W	Break interrupt Enable 0: Disable 1: Enable
8	UDIEN	R/W	Update DMA Request Enable 0: Disable 1: Enable
9	CC1DEN	R/W	Capture/Compare Channel1 DMA Request Enable 0: Disable 1: Enable
15:10	Reserved		

17.8.4 State register (TMRx_STS)

Offset address: 0x10

Reset value: 0x0000

Field	Name	R/W	Description
0	UIFLG	RC_W0	Update Event Interrupt Generate Flag 0: Update event interrupt does not occur 1: Update event interrupt occurs When the counter value is reloaded or reinitialized, an update event will be generated. The bit is set to 1 by hardware and cleared by software; update events are generated in the following situations: (1) UD=0 on TMRx_CTRL1 register, and when the value of the repeat

Field	Name	R/W	Description
			counter overruns/underruns, an update event will be generated; (2) URSSEL=0 and UD=0 on TMRx_CTRL1 register, configure UEG=1 on TMRx_CEG register to generate update event, and the counter needs to be initialized by software; (3) URSSEL=0 and UD=0 on TMRx_CTRL1 register, generate update event when the counter is initialized by trigger event.
1	CC1IFLG	RC_W0	<p>Capture/Compare Channel1 Interrupt Flag</p> <p>When the capture/compare channel 1 is configured as output: 0: No matching occurred 1: The value of TMRx_CNT matches the value of TMRx_CC1</p> <p>When the capture/compare channel 1 is configured as input: 0: Input capture did not occur 1: Input capture occurred</p> <p>When capture event occurs, the bit is set to 1 by hardware, and it can be cleared by software or cleared when reading TMRx_CC1 register.</p>
4:2	Reserved		
5	COMIFLG	RC_W0	<p>COM Event Interrupt Generate Flag</p> <p>0: COM event does not occur 1: COM interrupt waits for response</p> <p>After COM event is generated, this bit is set to 1 by hardware and cleared by software.</p>
6	Reserved		
7	BRKIFLG	RC_W0	<p>Break Event Interrupt Generate Flag</p> <p>0: Break event does not occur 1: Break event occurs</p> <p>When break input is valid, this bit is set to 1 by hardware; when break input is invalid, this bit can be cleared by software.</p>
8	Reserved		
9	CC1RCFLG	RC_W0	<p>Capture/compare Channel1 Repetition Capture Flag</p> <p>0: Repeat capture does not occur 1: Repeat capture occurs</p> <p>The value of the counter is captured to TMRx_CC1 register, and CC1IFLG=1; this bit is set to 1 by hardware and cleared by software only when the channel is configured as input capture.</p>
15:10	Reserved		

17.8.5 Control event generation register (TMRx_CEG)

Offset address: 0x14

Reset value: 0x0000

Field	Name	R/W	Description
-------	------	-----	-------------

Field	Name	R/W	Description
0	UEG	W	Update Event Generate 0: Invalid 1: Initialize the counter and generate the update event This bit is set to 1 by software, and cleared by hardware. Note: When an update event is generated, the counter of the prescaler will be cleared, but the prescaler factor remains unchanged. In the count-down mode, the counter reads the value of TMRx_AUTORLD; in center alignment mode or count-up mode, the counter will be cleared.
1	CC1EG	W	Capture/Compare Channel1 Event Generation 0: Invalid 1: Capture/Compare event is generated This bit is set to 1 by software and cleared automatically by hardware. If Channel 1 is in output mode: When CC1IFLG=1, if CC1IEN and CC1DEN bits are set, the corresponding interrupt and DMA request will be generated. If Channel 1 is in input mode: The value of the capture counter is stored in TMRx_CC1 register; configure CC1IFLG=1, and if CC1IEN and CC1DEN bits are also set, the corresponding interrupt and DMA request will be generated; at this time, if CC1IFLG=1, it is required to configure CC1RCFLG=1.
4:2	Reserved		
5	COMG	W	Capture/Compare Control Update Event Generate 0: Invalid 1: Capture/Compare update event is generated This bit is set to 1 by software and cleared automatically by hardware. Note: COMG bit is valid only in complementary output channel.
6	Reserved		
7	BEG	W	Break Event Generate 0: Invalid 1: Break event is generated This bit is set to 1 by software and cleared automatically by hardware.
15:8	Reserved		

17.8.6 Capture/Compare mode register 1 (TMRx_CCM1)

Offset address: 0x18

Reset value: 0x0000

The timer can be configured as input (capture mode) or output (compare mode) by CCxSEL bit. The functions of other bits of the register are different in input and output modes, and the functions of the same bit are different in output mode and input mode. The OCxx in the register describes the function of the channel in the output mode, and the ICxx in the register describes the function of the channel in the input mode.

Output compare mode:

Field	Name	R/W	Description
1:0	CC1SEL	R/W	Capture/Compare Channel 1 Select This bit defines the input/output direction and the selected input pin. 00: CC1 channel is output 01: CC1 channel is input, and IC1 is mapped on TI1 10: CC1 channel is input, and IC1 is mapped on TI2 11: CC1 channel is input, and IC1 is mapped on TRC, and only works in internal trigger input Note: This bit can be written only when the channel is closed (TMRx_CCEN register CC1EN=0).

Field	Name	R/W	Description
2	OC1FEN	R/W	Output Compare Channel1 Fast Enable 0: Disable 1: Enable This bit is used to improve the response of the capture/compare output to the trigger input event.
3	OC1PEN	R/W	Output Compare Channel1 Preload Enable 0: Preloading function is disabled; write the value of TMRx_CC1 register through the program and it will work immediately. 1: Preloading function is enabled; write the value of TMRx_CC1 register through the program and it will work after an update event is generated. Note: When the protection level is 3 and the channel is configured as output, this bit cannot be modified. When the preload register is uncertain, PWM mode can be used only in single pulse mode (SPMEN=1); otherwise, the following output compare result is uncertain.
6:4	OC1MOD	R/W	Output Compare Channel1 Mode Configure 000: Freeze The output compare has no effect on OC1REF 001: The output value is high when matching. When the value of counter CNT matches the value CCx of capture/compare register, OC1REF will be forced to be at high level 010: The output value is low when matching. When the value of the counter matches the value of the capture/compare register, OC1REF will be forced to be at low level 011: Output flaps when matching. When the value of the counter matches the value of the capture/compare register, flap the level of OC1REF 100: The output is forced to be low Force OC1REF to be at low level 101: The output is forced to be high. Force OC1REF to be at high level 110: PWM mode 1 (set to high when the counter value < output compare value; otherwise, set to low) 111: PWM mode 2 (set to high when the counter value > output compare value; otherwise, set to low) Note: When the protection level is 3 and the channel is configured as output, this bit cannot be modified. In PWM modes 1 and 2, the OC1REF level changes when the compare result changes or when the output compare mode changes from freeze mode to PWM mode.
15:7	Reserved		

Input capture mode:

Field	Name	R/W	Description
1:0	CC1SEL	R/W	Capture/Compare Channel 1 Select 00: CC1 channel is output 01: CC1 channel is input, and IC1 is mapped on TI1 10: CC1 channel is input, and IC1 is mapped on TI2 11: CC1 channel is input, and IC1 is mapped on TRC, and only works in internal trigger input Note: This bit can be written only when the channel is closed (TMRx_CCEN bit CC1EN=0).
3:2	IC1PSC	R/W	Input Capture Channel 1 Prescaler Configure 00: PSC=1 01: PSC=2 10: PSC=4 11: PSC=8 PSC is prescaled factor, which triggers capture once every PSC events.
7:4	IC1F	R/W	Input Capture Channel 1 Filter Configure 0000: Filter disabled, sampling by f_{DTS} 0001: DIV=1, N=2 0010: DIV=1, N=4 0011: DIV=1, N=8 0100: DIV=2, N=6 0101: DIV=2, N=8

Field	Name	R/W	Description
			0110: DIV=4, N=6 0111: DIV=4, N=8 1000: DIV=8, N=6 1001: DIV=8, N=8 1010: DIV=16, N=5 1011: DIV=16, N=6 1100: DIV=16, N=8 1101: DIV=32, N=5 1110: DIV=32, N=6 1111: DIV=32, N=8 Sampling frequency=timer clock frequency/DIV; the filter length=N, indicating that a jump is generated by every N events.
15:8			Reserved

17.8.7 Capture/Compare enable register (TMRx_CCEN)

Offset address: 0x20

Reset value: 0x0000

Field	Name	R/W	Description
0	CC1EN	R/W	Capture/Compare Channel1 Output Enable When the capture/compare channel 1 is configured as output: 0: Output is disabled 1: Output is enabled When the capture/compare channel 1 is configured as input: This bit determines whether the value CNT of the counter can be captured and enter TMRx_CC1 register 0: Capture is disabled 1: Capture is enabled
1	CC1POL	R/W	Capture/Compare Channel1 Output Polarity Configure When CC1 channel is configured as output: 0: OC1 high level is valid 1: OC1 low level is valid When CC1 channel is configured as input: CC1POL/CC1NPOL controls the polarity of the triggered or captured signals TI1FP1 and TI2FP1 at the same time 00: Non-phase-inverting/rising edge: TIxFP1 is not reversed phase (triggered in gated and encoder mode), and is captured at the rising edge of TIxFP1 (reset trigger, capture, external clock and trigger mode). 01: Inverted phase/Falling edge: TIxFP1 is reversed phase (triggered in gated and encoder mode), and is captured at the rising edge of TIxFP1 (reset trigger, capture, external clock and trigger mode). 10: Reserved 11: Non-phase-inverting/Rising and falling edges: TIxFP1 is not reversed phase (triggered in gated mode, cannot be used in encoder mode), and is captured at the rising edge of TIxFP1 (reset trigger, capture, external clock and trigger mode).
2	CC1NEN	R/W	Capture/Compare Channel1 Complementary Output Enable 0: Disable 1: Enable
3	CC1NPOL	R/W	Capture/Compare Channel1 Complementary Output Polarity 0: OC1N high level is valid 1: OC1N low level is valid

Field	Name	R/W	Description
			Note: When the protection level is 2 or 3, this bit cannot be modified
15:4			Reserved

17.8.8 Counter register (TMRx_CNT)

Offset address: 0x24

Reset value: 0x0000

Field	Name	R/W	Description
15:0	CNT	R/W	Counter Value

17.8.9 Prescaler register (TMRx_PSC)

Offset address: 0x28

Reset value: 0x0000

Field	Name	R/W	Description
15:0	PSC	R/W	Prescaler Value Clock frequency of counter (CK_CNT) = $f_{CK_PSC} / (PSC + 1)$

17.8.10 Auto reload register (TMRx_AUTORLD)

Offset address: 0x2C

Reset value: 0xFFFF

Field	Name	R/W	Description
15:0	AUTORLD	R/W	Auto Reload Value When the value of auto reload is empty, the counter will not count.

17.8.11 Repeat count register (TMRx_REPCNT)

Offset address: 0x30

Reset value: 0x0000

Field	Name	R/W	Description
7:0	REPCNT	R/W	Repetition Counter Value When the count value of the repeat counter is reduced to 0, an update event will be generated, and the counter will start counting again from the REPCNT value; the new value newly written to this register is valid only when an update event occurs in next cycle.
15:8			Reserved

17.8.12 Channel 1 capture/compare register (TMRx_CC1)

Offset address: 0x34

Reset value: 0x0000

Field	Name	R/W	Description
15:0	CC1	R/W	Capture/Compare Channel 1 Value When the capture/compare channel 1 is configured as input mode: CC1 contains the counter value transmitted by the last input capture channel 1 event. When the capture/compare channel 1 is configured as output mode: CC1 contains the current load capture/compare register value Compare the value CC1 of the capture and compare channel 1 with the value CNT of the counter to generate the output signal on OC1. When the output compare preload is disabled (OC1PEN=0 for TMRx_CCM1

Field	Name	R/W	Description
			register), the written value will immediately affect the output compare results; If the output compare preload is enabled (OC1PEN=1 for TMRx_CCM1 register), the written value will affect the output compare result when an update event is generated.

17.8.13 Break and dead-time register (TMRx_BDT)

Offset address: 0x44

Reset value: 0x0000

Note: According to the lock setting, AOEN, BRKPOL, BRKEN, IMOS, RMOS and DTS[7:0] bits all can be write-protected, and it is necessary to configure them when writing to TMRx_BDT register for the first time.

Field	Name	R/W	Description
7:0	DTS	R/W	<p>Dead Time Setup</p> <p>DT is the dead duration, and the relationship between DT and register DTS is as follows:</p> <p>$DTS[7:5]=0xx \Rightarrow DT=DTS[7:0] \times T_{DTS}, T_{DTS}=T_{DTS};$</p> <p>$DTS[7:5]=10x \Rightarrow DT=(64+DTS[5:0]) \times T_{DTS}, T_{DTS}=2 \times T_{DTS};$</p> <p>$DTS[7:5]=110 \Rightarrow DT=(32+DTS[4:0]) \times T_{DTS}, T_{DTS}=8 \times T_{DTS};$</p> <p>$DTS[7:5]=111 \Rightarrow DT=(32+DTS[4:0]) \times T_{DTS}, T_{DTS}=16 \times T_{DTS};$</p> <p>For example: assuming $T_{DTS}=125ns$ (8MHZ), the dead-time time setting is as follows:</p> <p>If the step time is 125ns, the dead time can be set from 0 to 15875ns;</p> <p>If the step time is 250ns, the dead time can be set from 16μs to 31750ns;</p> <p>If the step time is 1μs, the dead time can be set from 32μs to 63μs;</p> <p>If the step time is 2μs, the dead time can be set from 64μs to 126μs.</p> <p>Note: Once LOCK level (LOCKCFG bit in TMRx_BDT register) is set to 1, 2 or 3, these bits cannot be modified.</p>
9:8	LOCKCFG	R/W	<p>Lock Write Protection Mode Configure</p> <p>00: Without Lock write protection level; the register can be written directly</p> <p>01: Lock write protection level 1</p> <p>It cannot be written to DTS, BRKEN, BRKPOL and AOEN bits of TMRx_BDT, and OCxOIS and OCxNOIS bits of TMRx_CTRL2 register.</p> <p>10: Lock write protection level 2</p> <p>It is not allowed to write to all bits with protection level 1 and write to the CCxPOL and OCxNPOL bits in TMRx_CCEN register and the RMOS and IMOS bits in TMRx_BDT register.</p> <p>11: Lock write protection level 3</p> <p>It is not allowed to write to all bits with protection level 2, and write to the OCxMOD and OCxPEN bits of TMRx_CCMx register.</p> <p>Note: After system reset, the lock write protect bit can only be written once.</p>
10	IMOS	R/W	<p>Idle Mode Off-state Configure</p> <p>Idle mode means MOEN=0; closed means CcxEN=0; this bit describes the impact of different values for this bit on the output waveform when MOEN=0 and CcxEN changes from 0 to 1.</p> <p>0: OCx/OCxN output is disabled</p> <p>1: If CCxEN=1, the invalid level is output during the dead time (the specific level value is affected by the polarity configuration), and the idle level is output after the dead time</p>
11	RMOS	R/W	<p>Run Mode Off-state Configure</p> <p>Run mode means MOEN=1; closed means CcxEN=0; this bit describes the impact of different values for this bit on the output waveform when MOEN=1 and CcxEN changes from 0 to 1.</p> <p>0: OCx/OCxN output is disabled</p> <p>1: OCx/OCxN first output invalid level (the specific level value is affected by the polarity configuration)</p>
12	BRKEN	R/W	<p>Break Function Enable</p> <p>0: Disable</p> <p>1: Enable</p> <p>Note: When the protection level is 1, this bit cannot be modified.</p>

Field	Name	R/W	Description
13	BRKPOL	R/W	Break Polarity Configure 0: The break input BRK is valid at low level 1: The break input BRK is valid at high level Note: When the protection level is 1, this bit cannot be modified. Writing to this bit requires an APB clock delay before it can be used.
14	AOEN	R/W	Automatic Output Enable 0: MOEN can only be set to 1 by software 1: MOEN can be set to 1 by software or be automatically set to 1 in next update event (breaking input is ineffective) Note: When the protection level is 1, this bit cannot be modified.
15	MOEN	R/W	PWM Main Output Enable 0: Disable the output of OCx and OCxN or force the output of idle state 1: When CCxEN and CCxNEN bits of the TMRx_CCEN register are set, turn on OCx and OCxN output When the break input is valid, it is cleared by hardware asynchronously. Note: Setting to 1 by software or setting to 1 automatically depends on AOEN bit of the TMRx_BDT register.

17.8.14 DMA control register (TMRx_DCTRL)

Offset address: 0x48

Reset value: 0x0000

Field	Name	R/W	Description
4:0	DBADDR	R/W	DMA Base Address Setup These bits define the base address of DMA in continuous mode (when reading or writing TMRx_DMADDR register), and DBADDR is defined as the offset from the address of TMRx_CTRL1 register: 00000: TMRx_CTRL1 00001: TMRx_CTRL2 00010: TMRx_SMCTRL
7:5	Reserved		
12:8	DBLEN	R/W	DMA Burst Transfer Length Setup These bits define the transfer length and transfer times of DMA in continuous mode. The data transferred can be 16 bits and 8 bits. When reading/writing TMRx_DMADDR register, the timer will conduct a continuous transmission; 00000: Transmission for 1 time 00001: Transmission for 2 times 00010: Transmission for 3 times 10001: Transmission for 18 times The transmission address formula is as follows: Transmission address=TMRx_CTRL1 address (slave address) +DBADDR+DMA index; DMA index=DBLEN For example: DBLEN=7, DBADDR=TMR1_CTRL1 (slave address) means the address of the data to be transmitted, while the address +DBADDR+7 of TMRx_CTRL1 means the address of the data to be written/read, Data transmission will occur to: TMRx_CTRL1 address + seven registers starting from DBADDR. The data transmission will change according to different DMA data length: When the transmission data is set to 16 bits, the data will be transmitted to seven registers

Field	Name	R/W	Description
			When the transmission data is set to 8 bits, the data of the first register is the MSB bit of the first data, the data of the second register is the LSB bit of the first data, and the data will still be transmitted to seven registers.
15:13			Reserved

17.8.15 DMA address register of continuous mode (TMRx_DMADDR)

Offset address: 0x4C

Reset value: 0x0000

Field	Name	R/W	Description
15:0	DMADDR	R/W	<p>DMA Register for Burst Transfer</p> <p>Read or write operation access of TMRx_DMADDR register may lead to access operation of the register in the following address: $TMRx_CTRL1\ address + (DBADDR + DMA\ index) \times 4$</p> <p>Wherein: "TMRx_CTRL1 address" is the address of control register 1 (TMRx_CTRL1); "DBADDR" is the base address defined in TMRx_DCTRL register; "DMA index" is the offset automatically controlled by DMA, and it depends on DBLEN defined in TMRx_DCTRL register.</p>

18 Advanced Timer (TMR1)

18.1 Introduction

The advanced timer TMR1 takes the time base unit as the core, and has the functions of input capture, output compare and breaking input, including a 16-bit auto load counter. Compared with other timers, the advanced timer supports complementary output, repeat count and programmable dead-time insertion function, and is more suitable for motor control.

18.2 Main Characteristics

- (1) Timebase unit
 - Counter: 16-bit counter, count-up, count-down and center alignment count
 - Prescaler: 16-bit programmable prescaler
 - Repeat counter: 16-bit repeat counter
 - Auto reloading function
- (2) Clock source selection
 - Internal clock
 - External input
 - External trigger
 - Internal trigger
- (3) Input capture function
 - Counting function
 - PWM input mode (measurement of pulse width, frequency and duty cycle)
 - Encoder interface mode
- (4) Output compare function
 - PWM output mode
 - Forced output mode
 - Single-pulse mode
 - Complementary output and dead-time insertion
- (5) Timing function
- (6) Breaking function
- (7) Master/Slave mode controller of timer
 - Timers can be synchronized and cascaded
 - Support multiple slave modes and synchronization signals
- (8) Interrupt output and DMA request event
 - Update event (counter overrun/underrun, counter initialization)
 - Trigger event (counter start, stop, internal/external trigger)
 - Capture/Compare event
 - Breaking signal input event

18.3 Structure Block Diagram

Table 67 TMR1 Structure Block Diagram

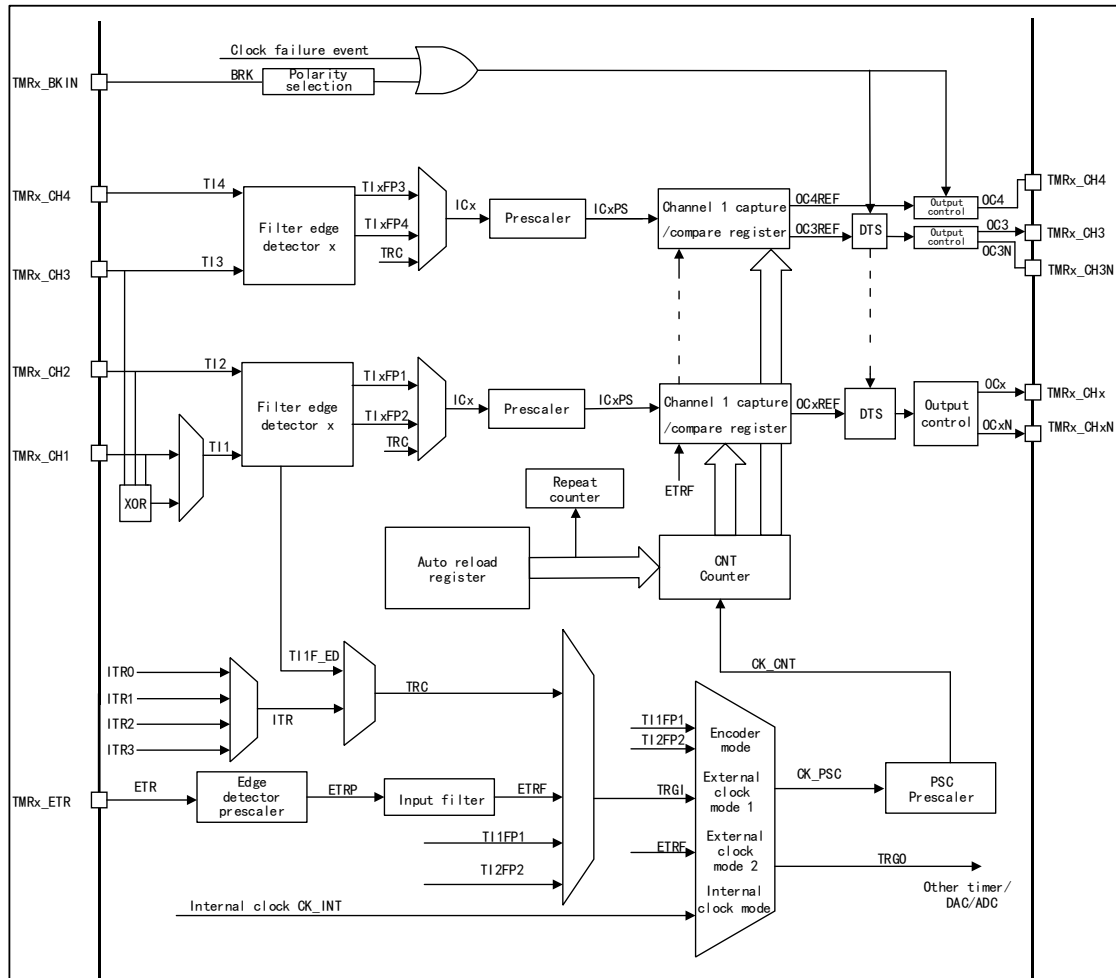

18.4 Functional Description

18.4.1 Clock Source Selection

The advanced timer has four clock sources

Internal clock

It is TMR1_CLK from RCM, namely the driving clock of the timer; when the slave mode controller is disabled, the clock source CK_PSC of the prescaler is driven by the internal clock CK_INT.

External clock mode 1

The trigger signal generated from the input channel TI1/2/3/4 of the timer after polarity selection and filtering is connected to the slave mode controller to control the work of the counter. Besides, the pulse signal generated by the input of Channel 1 after double-edge detection of the rising edge and the falling edge is logically equal or the future signal is TI1F_ED signal, namely double-edge signal

of TIF_ED. Specially the PWM input can only be input by TI1/2.

External clock mode 2

After polarity selection, frequency division and filtering, the signal from external trigger interface (ETR) is connected to slave mode controller through trigger input selector to control the work of counter.

Internal trigger input

The timer is set to work in slave mode, and the clock source is the output signal of other timers. At this time, the clock source has no filtering, and the synchronization or cascading between timers can be realized. The master mode timer can reset, start, stop or provide clock for the slave mode timer.

18.4.2 Timebase Unit

The time base unit in the advanced timer contains four registers

- Counter register (CNT) 16 bits
- Auto reload register (AUTORLD) 16 bits
- Prescaler register (PSC) 16 bits
- Repetition count register (REPCNT) 8 bits

Counter CNT

There are three counting modes for the counter in the advanced timer

- Count-up mode
- Count-down mode
- Center alignment mode

Count-up mode

Set to the count-up mode by CNTDIR bit of configuration control register (TMR1_CTRL1).

When the counter is in count-up mode, the counter will count up from 0; every time a pulse is generated, the counter will increase by 1 and when the value of the counter (TMR1_CNT) is equal to the value of the auto reload (TMR1_AUTORLD), the counter will start to count again from 0, a count-up overrun event will be generated, and the value of the auto reload (TMR1_AUTORLD) is written in advance.

When the counter overruns, an update event will be generated. At this time, the repeat count shadow register, the auto reload shadow register and the prescaler buffer will be updated. The update event can be disabled by UD bit of configuration control register TMR1_CTRL1.

The figure below is Timing Diagram when Division Factor is 1 or 2 in Count-up Mode

Figure 68 Timing Diagram when Division Factor is 1 or 2 in Count-up Mode

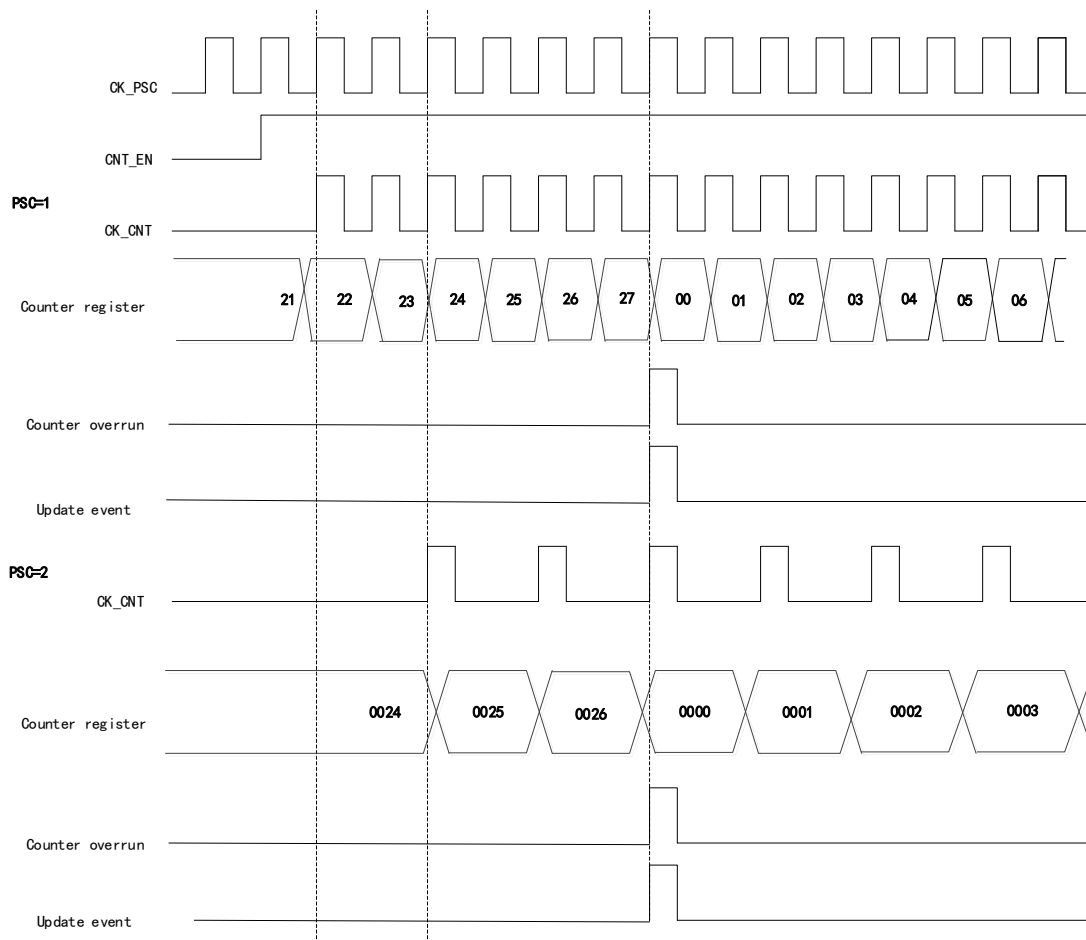

Count-down mode

Set to the count-down mode by CNTDIR bit of configuration control register (TMR1_CTRL1).

When the counter is in count-down mode, the counter will start to count down from the value of the auto reload (TMR1_AUTORLD); every time a pulse is generated, the counter will decrease by 1 and when it becomes 0, the counter will start to count again from (TMR1_AUTORLD), meanwhile, a count-down overrun event will be generated, and the value of the auto reload (TMR1_AUTORLD) is written in advance.

When the counter overruns, an update event will be generated. At this time, the repeat count shadow register, the auto reload shadow register and the prescaler buffer will be updated. The update event can be disabled by configuring the UD bit of the TMR1_CTRL1 register.

Figure 69 Timing Diagram when Division Factor is 1 or 2 in Count-down Mode

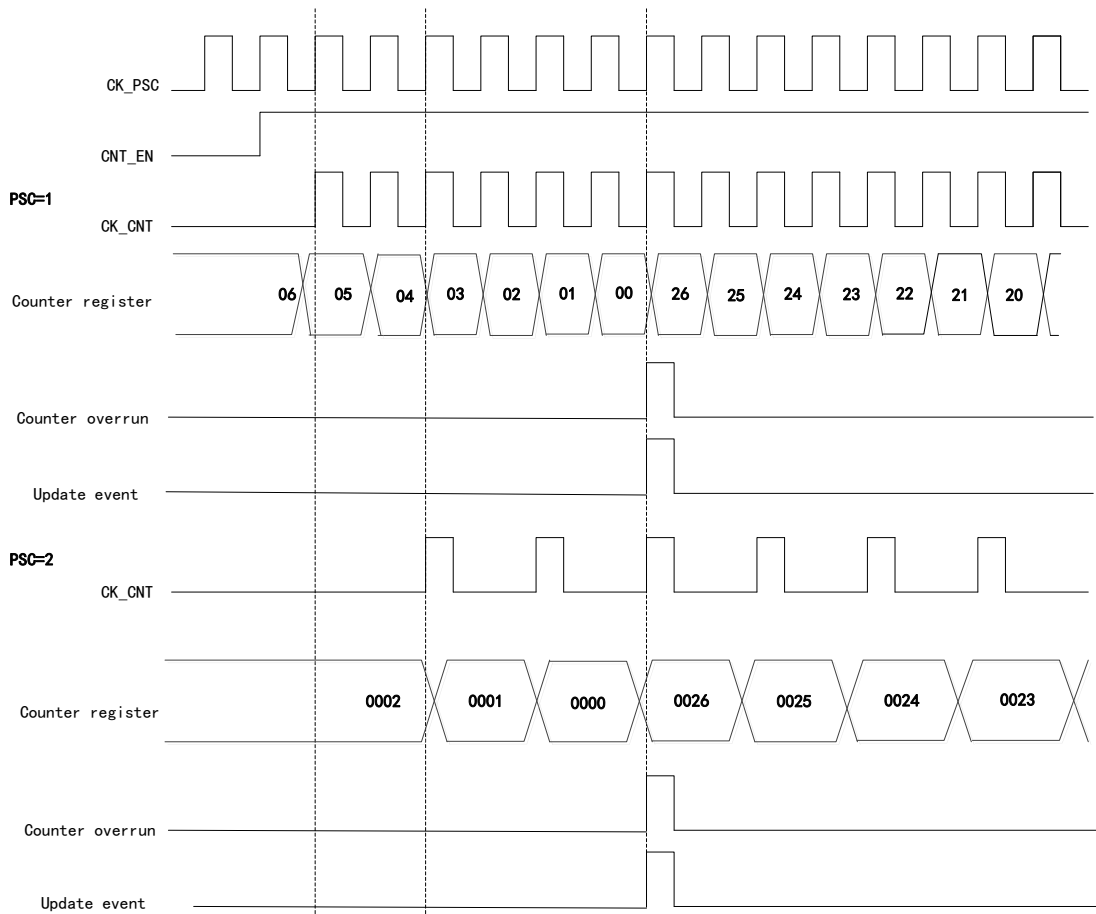

Center alignment mode

Set to the center alignment mode by CNTDIR bit of configuration control register (TMR1_CTRL1).

When the counter is in central alignment mode, the counter counts up from 0 to the value of auto reload (TMR1_AUTORLD), then counts down to 0 from the value of the auto reload (TMR1_AUTORLD), which will repeat; in counting up, when the counter value is (AUTORLD-1), a counter overrun event will be generated; in counting down, when the counter value is 1, a counter underrun event will be generated.

Figure 70 Timing Diagram when Division Factor is 1 or 2 in Center Alignment Mode

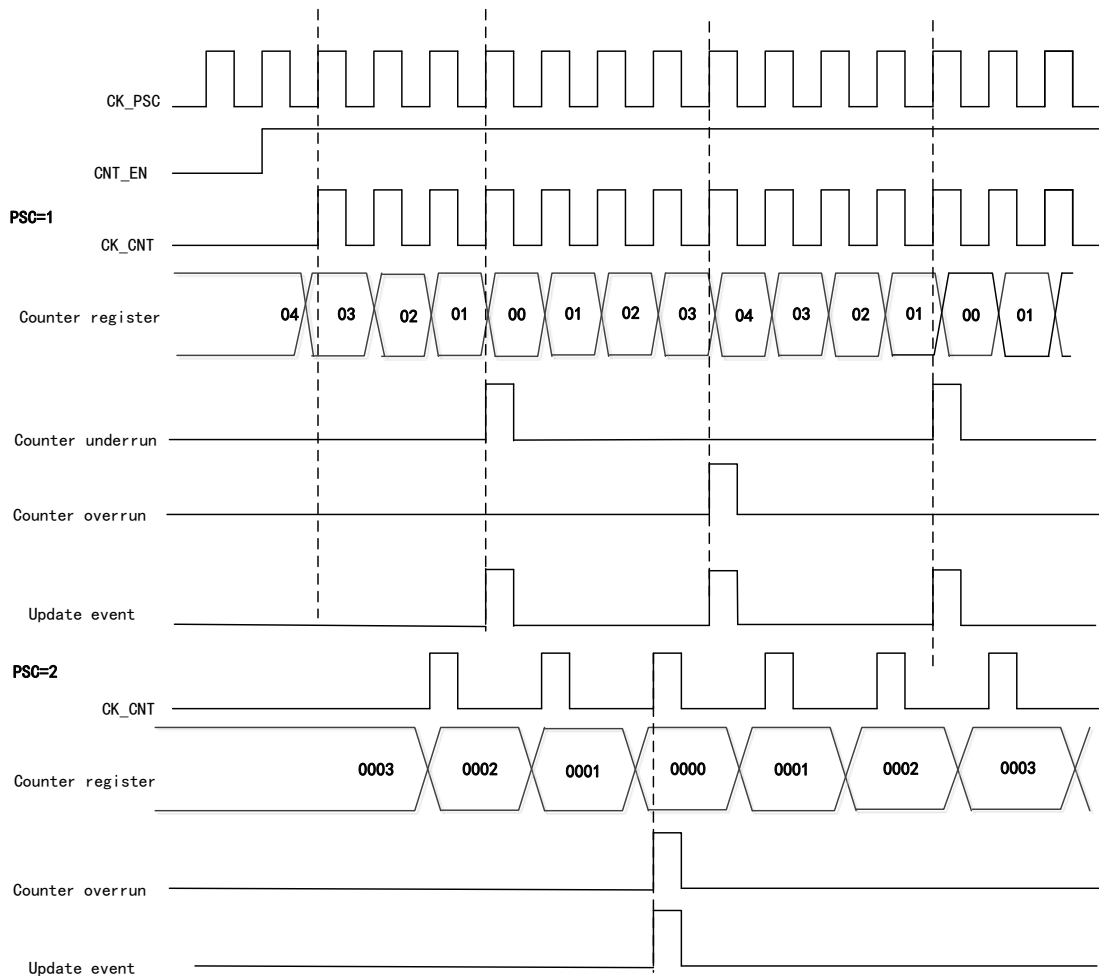

Repeat counter REPCNT

There is no repeat counter REPCNT in the basic/general-purpose timer, which means that when the overrun event or underrun event occurs in the basic/general-purpose timer, an update event will be generated directly; while in the advanced timer, because of the existence of the repeat counter, when an overrun/underrun event occurs to the advanced timer, the update event will be generated only when the value of the repeat counter is 0.

For example, if the advanced timer needs to generate an update event when an overrun/underrun event occurs, the value of the repeat counter should be set to 0.

If the repeat counter function is used in the count-up mode, every time the counter counts up to AUTORLD, an overrun event will occur. At this time, the value of the repeat counter will be decreased by 1, and an update event will be generated until the value of the repeat counter is 0.

That is, when N+1 (N is the value of repeat counter) overrun/underrun events occur, an update event will be generated.

Figure 71 Timing Diagram when Setting REPCNT=2 in Count-up Mode

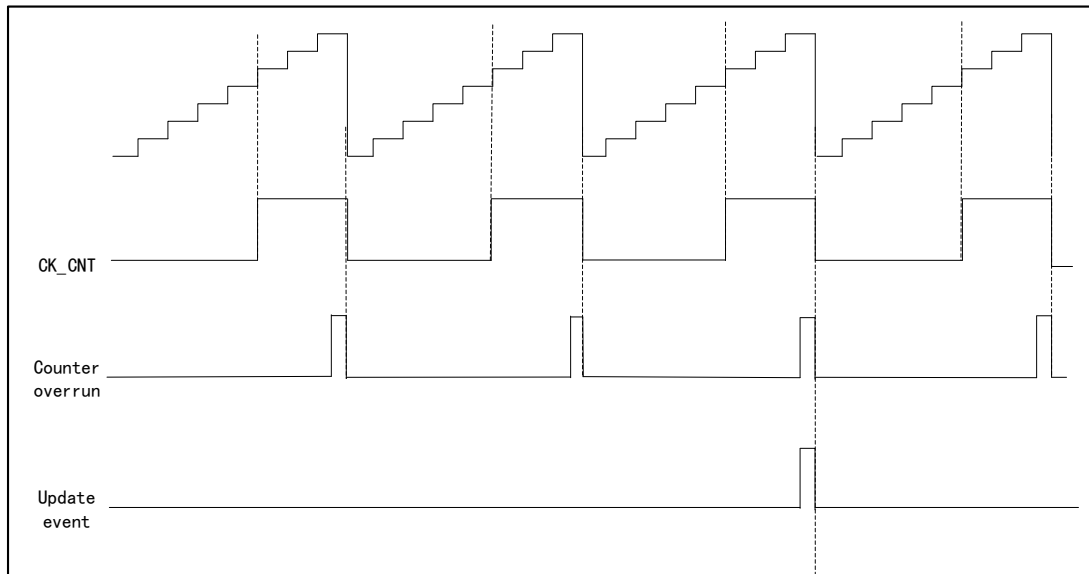

Prescaler PSC

The prescaler is 16 bits and programmable, and it can divide the clock frequency of the counter to any value between 1 and 65536 (controlled by TMR1_PSC register), and after frequency division, the clock will drive the counter CNT to count. The prescaler has a buffer, which can be changed during running.

18.4.3 Input Capture

Input capture channel

The advanced timer has four independent capture/compare channels, each of which is surrounded by a capture/compare register.

In the input capture, the measured signal will enter from the external pin T1/2/3/4 of the timer, first pass through the edge detector and input filter, and then into the capture channel. Each capture channel has a corresponding capture register. When the capture occurs, the value of the counter CNT will be latched in the capture register CCx. Before entering the capture register, the signal will pass through the prescaler, which is used to set how many events to capture at a time.

Input capture application

Input capture is used to capture external events, and can give the time flag to indicate the occurrence time of the event and measure the pulse jump edge events (measure the frequency or pulse width), for example, if the selected edge appears on the input pin, the TMR1_CCx register will capture the current value of the counter and the CCxIFLG bit of the state register TMR1_STS will be set to 1; if CCxIEN=1, an interrupt will be generated.

In capture mode, the timing, frequency, period and duty cycle of a waveform can be measured. In the input capture mode, the edge selection is set to rising edge detection. When the rising edge appears on the capture channel, the first capture occurs, at this time, the value of the counter CNT will be latched in the capture register CCx; at the same time, it will enter the capture interrupt, a capture will be recorded in the interrupt service program and the value will be recorded. When the next rising edge is detected, the second capture occurs, the

value of counter CNT will be latched in capture register CCx again, at this time, it will enter the capture interrupt again, the value of capture register will be read, and the cycle of this pulse signal will be obtained through capture.

18.4.4 Output Compare

There are eight modes of output compare: freeze, channel x is valid level when matching, channel x is invalid level when matching, flip, force is invalid, force is valid, PWM1 and PWM mode 2, which are configured by OCxMOD bit in TMR1_CCMx register and can control the waveform of output signal in output compare mode.

Output compare application

In the output compare mode, the position, polarity, frequency and time of the pulse generated by the timer can be controlled.

When the value of the counter is equal to that of the capture/compare register, the channel output can be set as high level, low level or flip by configuring the OCxMOD bit in TMR1_CCMx register and the CCxPOL bit in the output polarity TMR1_CCEN register.

When CCxIFLG=1 in TMR1_STS register, if CCxIEN=1 in TMR1_DIEN register, an interrupt will be generated; if CCDSEL=1 in TMR1_CTRL2 register, DMA request will be generated.

18.4.5 PWM Output Mode

PWM mode is an adjustable pulse signal output by the timer. The pulse width of the signal is determined by the value of the compare register CCx, and the cycle is determined by the value of the auto reload AUTORLD.

PWM output mode contains PWM mode 1 and PWM mode 2; PWM mode 1 and PWM mode 2 are divided into count-up, count-down and edge alignment counting; in PWM mode 1, if the value of the counter CNT is less than the value of the compare register CCx, the output level will be valid; otherwise, it will be invalid.

Set the timing diagram in PWM mode 1 when CCx=5, AUTORLD=7

Figure 72 PWM1 Count-up Mode Timing Diagram

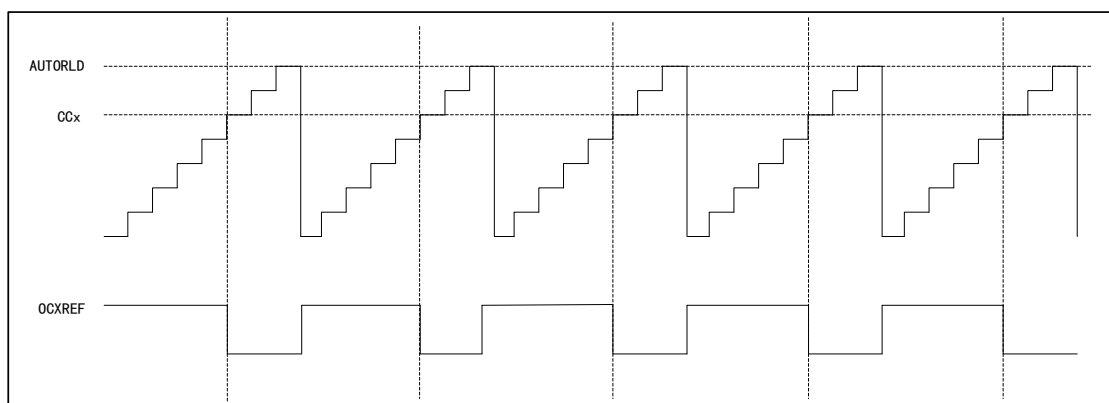

Figure 73 PWM1 Count-down Mode Timing Diagram

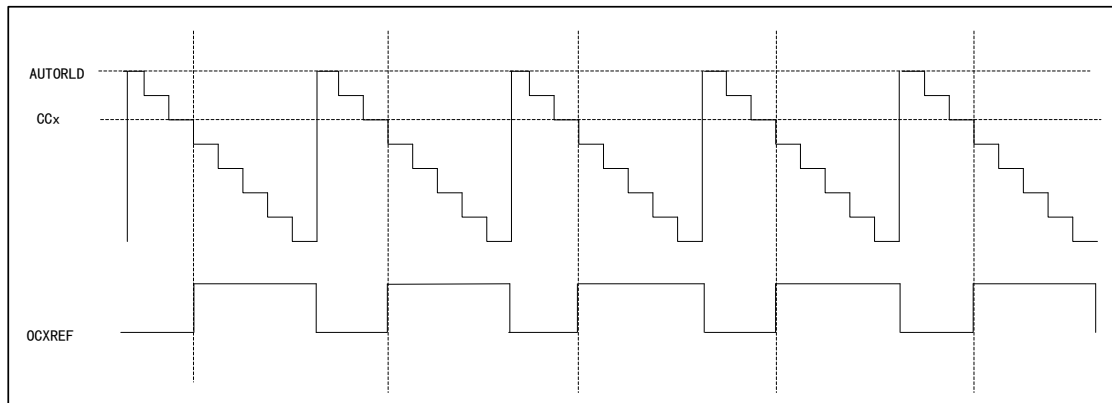
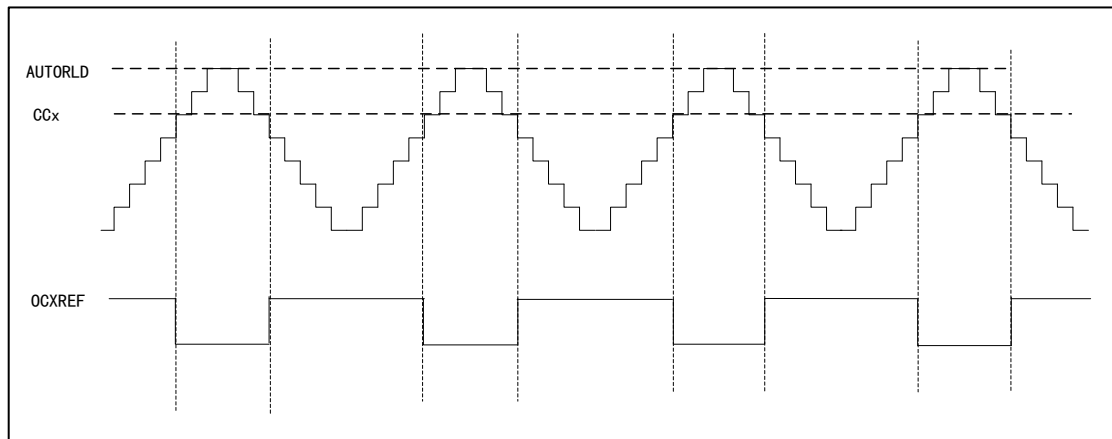

Figure 74 PWM1 Center Alignment Mode Timing Diagram



In PWM mode 2, if the value of the counter CNT is less than that of the compare register CCx, the output level will be invalid; otherwise, it will be valid.

Set the timing diagram in PWM mode 2 when CCx=5, AUTORLD=7

Figure 75 PWM2 Count-up Mode Timing Diagram

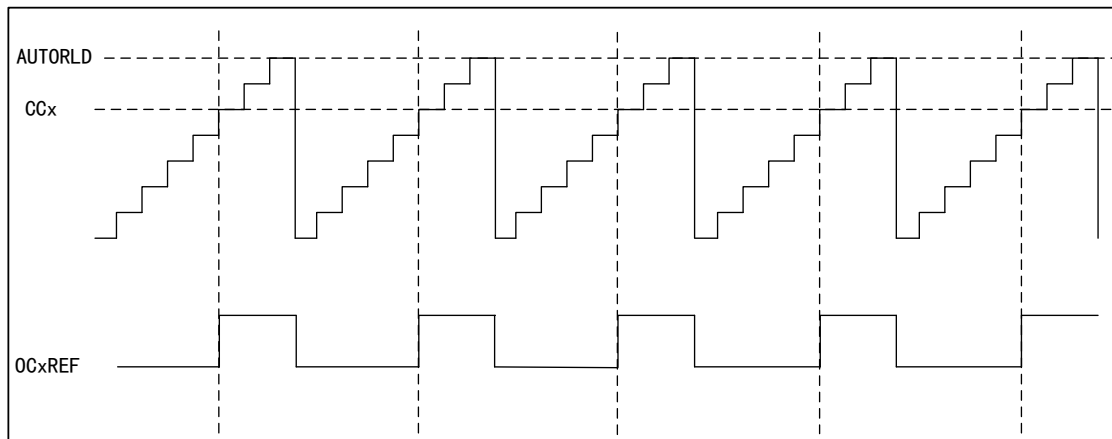

Figure 76 PWM2 Count-down Mode Timing Diagram

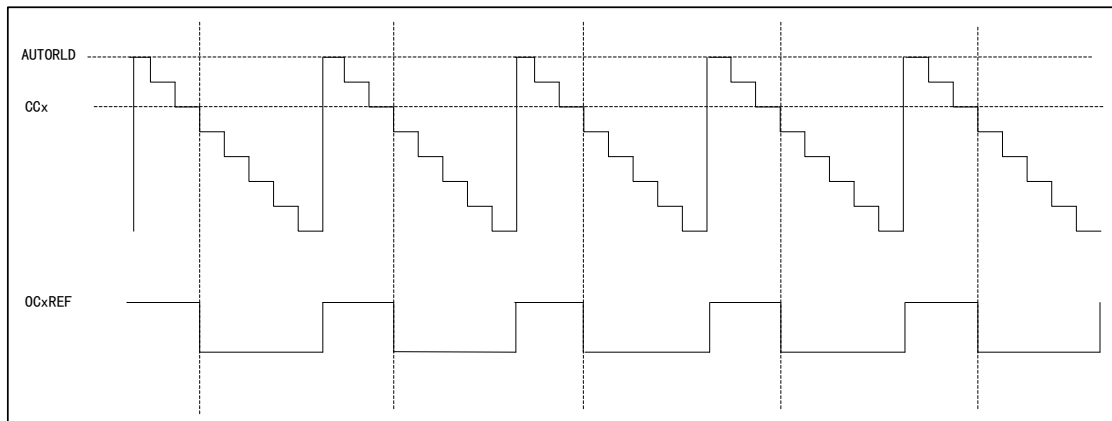
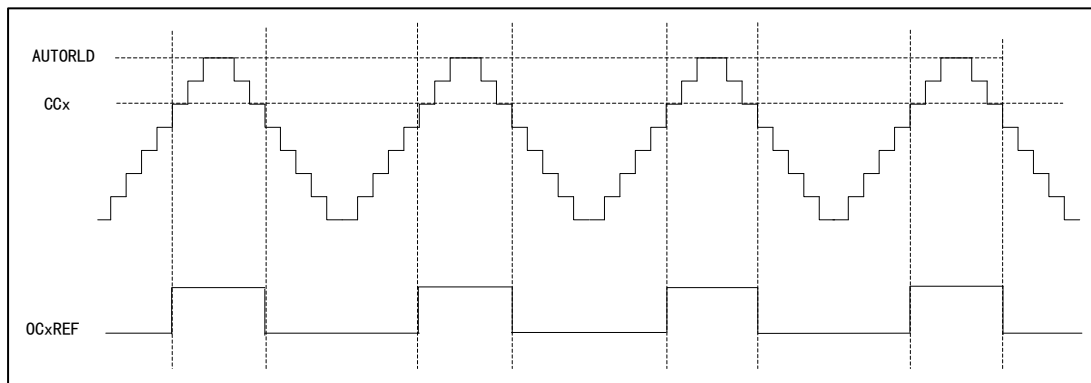

Figure 77 PWM2 Center Alignment Mode Timing Diagram



18.4.6 PWM Input Mode

PWM input mode is a particular case of input capture.

In PWM input mode, as only TI1FP1 and TI1FP2 are connected to the slave mode controller, input can be performed only through the channels TMR1_CH1 and TMR1_CH2, which need to occupy the capture registers of CH1 and CH2.

In the PWM input mode, the PWM signal enters from TMR1_CH1, and the signal will be divided into two channels, one can measure the cycle and the other can measure the duty cycle. In the configuration, it is only required to set the polarity of one channel, and the other will be automatically configured with the opposite polarity.

In this mode, the slave mode controller should be configured as the reset mode (SMFSEL bit of TMR1_SMCTRL register)

Figure 78 PWM Input Mode Timing Diagram

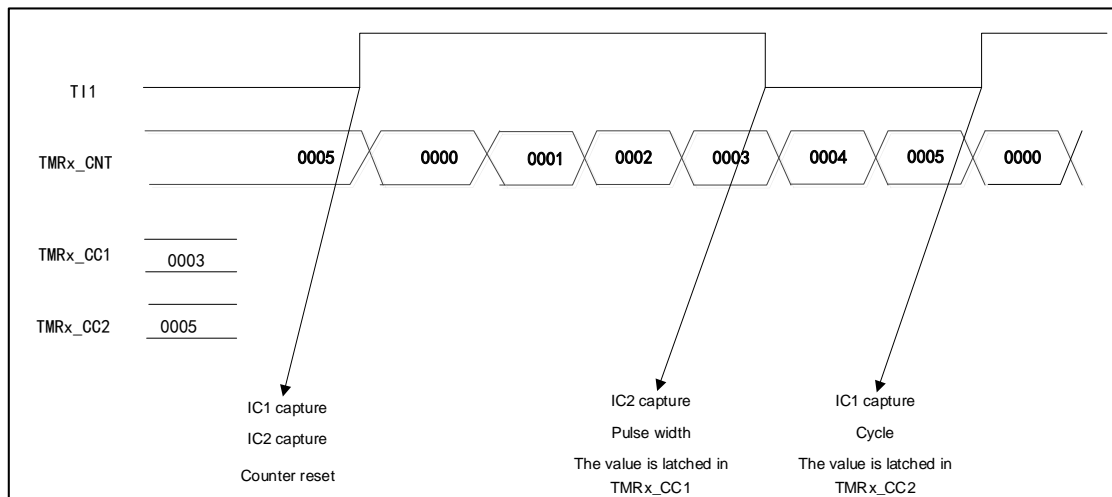

18.4.7 Single-pulse Mode

The single-pulse mode is a special case of timer compare output, and is also a special case of PWM output mode.

Set SPEN bit of TMR1_CTRL1 register, and select the single-pulse mode. After the counter is started, a certain number of pulses will be output before the update event occurs. When the update event occurs, the counter will stop counting, and the subsequent PWM waveform output will no longer be changed.

After a certain controllable delay, a pulse with controllable pulse width is generated in single-pulse mode through the program. The delay time is defined by the value of TMR1_CCx register; in the count-up mode, the delay time is CCx and the pulse width is AUTORLD-CCx; in the count-down mode, the delay time is AUTORLD-CCx and the pulse width is CCx.

Figure 79 Single-pulse Mode Timing Diagram

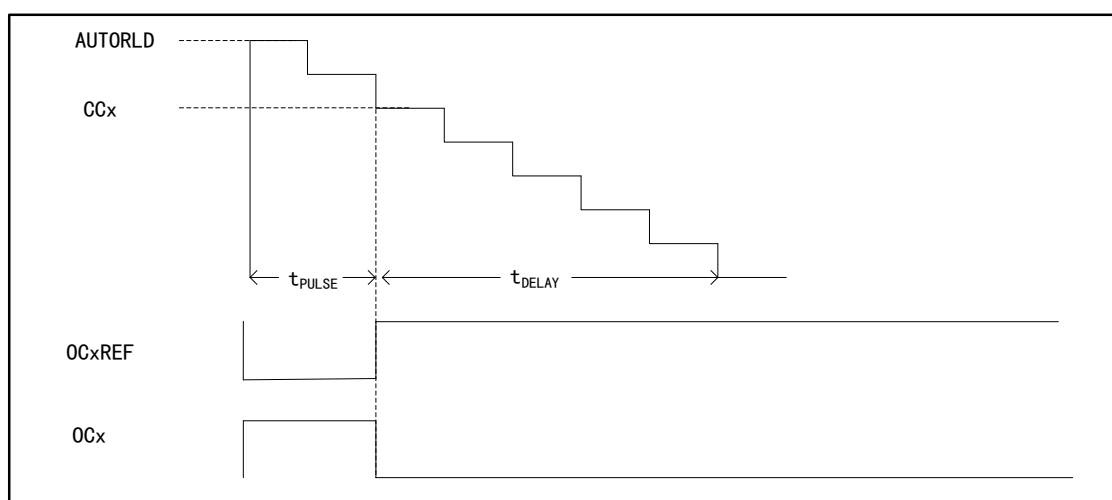

18.4.8 Impact of the Register on Output Waveform

The following registers will affect the level of the timer output waveform. For

details, please refer to “Register Functional Description”.

- (1) CCxEN and CCxNEN bits in TMR1_CCEN register
 - CCxNEN=0 and CCxEN=0: The output is turned off (output disabled, invalid state)
 - CCxNEN=1 and CCxEN=1: The output is turned on (output enabled, normal output)
- (2) MOEN bit in TMR1_BDT register
 - MOEN=0: Idle mode
 - MOEN=1: Run mode
- (3) OCxOIS and OCxNOIS bits in TMR1_CTRL2 register
 - OCxOIS=0 and OCxNOIS=0: When idle (MOEN=0), the output level after the dead-time is 0
 - OCxOIS=1 and OCxNOIS=1: When idle (MOEN=0), the output level after the dead-time is 1
- (4) RMOS bit in TMR1_BDT register
 - Application environment of RMOS: In corresponding complementary channel and timer run mode (MOEN=1), the timer is not working (CCxEN=0, CCxNEN=0) or is working (CCxEN=1, CCxNEN=1)
- (5) IMOS bit in TMR1_BDT register
 - Application environment of IMOS: In corresponding complementary channel and timer are in idle mode (MOEN=0), the timer is not working (CCxEN=0, CCxNEN=0) or is working (CCxEN=1, CCxNEN=1)
- (6) CCxPOL and CCxNPOL bits in TMR1_CCEN register
 - CCxPOL=0 and CCxNPOL=0: Output polarity, high level is valid
 - CCxPOL=1 and CCxNPOL=1: Output polarity, the low level is valid

The following figure lists the register structure relationships that affect the output waveform

Figure 80 Register Structural Relationship Affecting Output Waveform

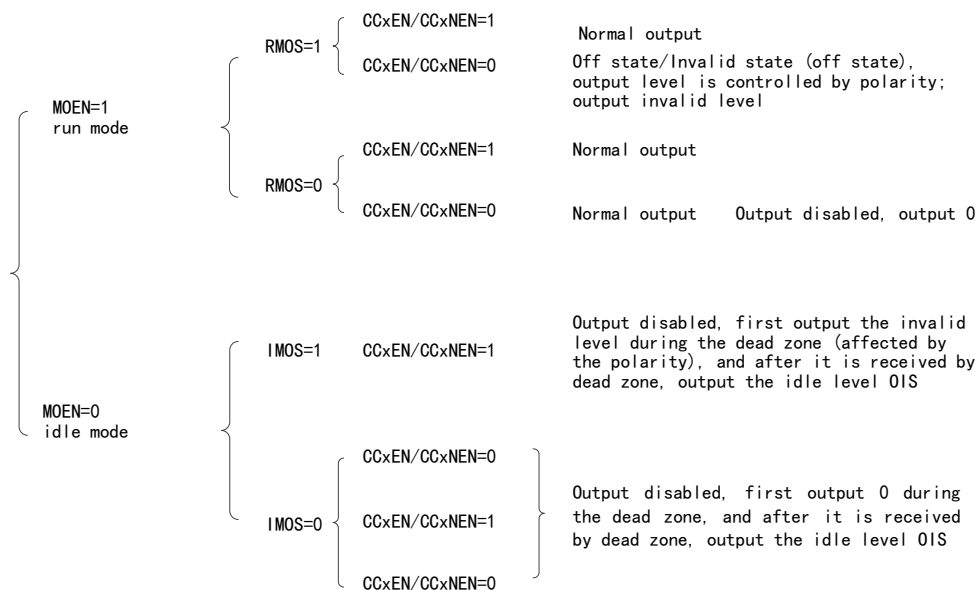

18.4.9 Breaking Function

The signal source of breaking is clock fault event and external input interface.

Besides, the BRKEN bit in TMR1_BDT register can enable the breaking function, and the BRKPOL bit can configure the polarity of breaking input signal.

When a breaking event occurs, the output pulse signal level can be modified according to the state of the relevant control bit.

Figure 81 Breaking Event Timing Diagram

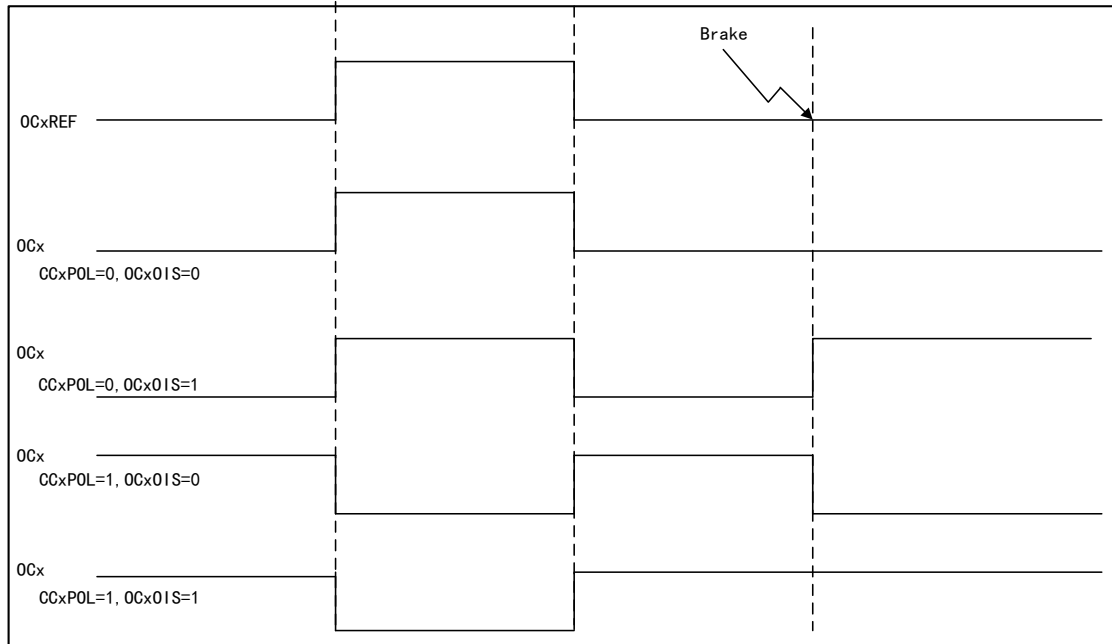

18.4.10 Complementary Output and Dead-time Insertion

Timer 1 has three groups of complementary 209chmit channels. The insertion dead time is used to generate complementary output signals to ensure that the two-way complementary signals of channels will not be valid at the same time. The dead time is set according to the output device connected to the timer and its characteristics

The duration of the dead-time can be controlled by configuring DTS bit of TMR1_BDT register

Figure 82 Complementary Output of Insertion with Dead-time

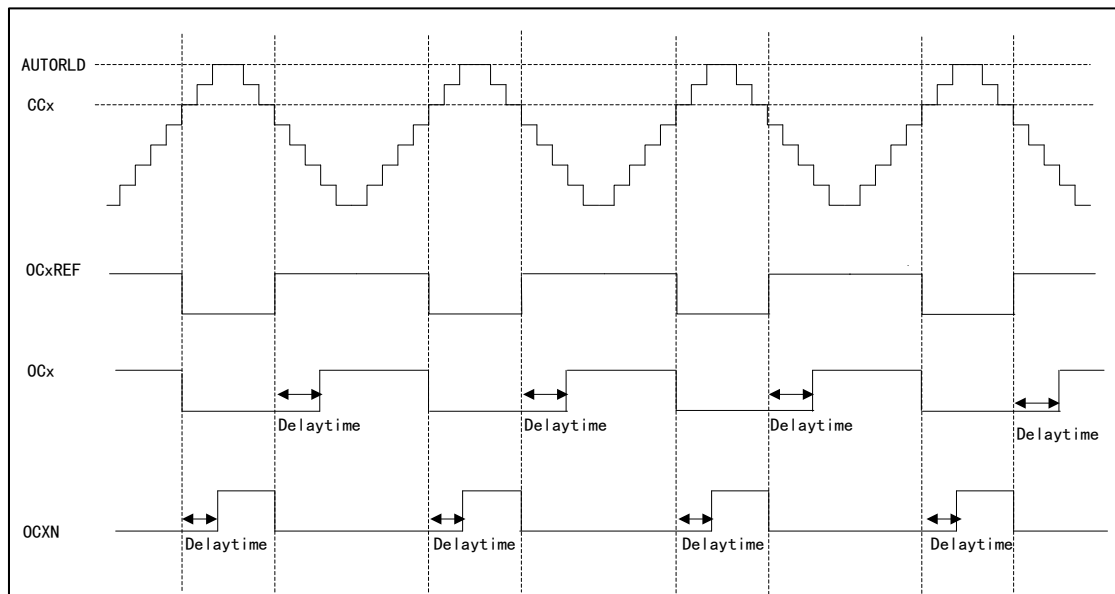

18.4.11 Forced Output Mode

In the forced output mode, the compare result is ignored, and the corresponding level is directly output according to the configuration instruction.

- CCxSEL=00 for TMR1_CCMx register, set CCx channel as output
- OCxMOD=100/101 for TMR1_CCMx register, set to force OCxREF signal to invalid/valid state

In this mode, the corresponding interrupt and DMA request will still be generated.

18.4.12 Encoder Interface Mode

The encoder interface mode is equivalent to an external clock with direction selection. In the encoder interface mode, the content of the timer can always indicate the position of the encoder.

The selection methods of encoder interface is as follows:

- By setting SMFSEL bit of TMR1_SMCTRL register, set the counter to count on the edge of T11 channel /T12 channel, or count on the edge of T11 and T12 at the same time.
- Select the polarity of T11 and T12 by setting the CC1POL and CC2POL bits of TMR1_CCEN register.
- Select to filter or not by setting the IC1F and IC2F bits of TMR1_CCM1 register.

The two input T11 and T12 can be used as the interface of incremental encoder. The counter is driven by the effective jump of the signals T11FP1 and T12FP2 after filtering and edge selection in T11 and T12.

The count pulse and direction signal are generated according to the input signals of T11 and T12

- The counter will count up/down according to the jumping sequence of the input signal
- Set CNTDIR of control register TMR1_CTRL1 to be read-only (CNTDIR will be re-calculated due to jumping of any input end)

The change mechanism of counter count direction is shown in the figure below

Table 56 Relationship between Count Direction and Encoder

Effective edge		Count only in T11		Count only in T12		Count in both T11 and T12	
Level of relative signal		High	Low	High	Low	High	Low
T11FP1	Rising edge	—		Count down	Count up	Count down	Count up
	Falling edge			Count up	Count down	Count up	Count down
T12FP2	Rising edge	Count up	Count down	—		Count up	Count down
	Falling edge	Count down	Count up			Count down	Count up

The external incremental encoder can be directly connected with MCU, not needing external interface logic, so the comparator is used to convert the differential output of the encoder to digital signal to increase the immunity from noise interference.

Among the following examples,

- IC1FP1 is mapped to T11
- IC2FP2 is mapped to T12
- Neither IC1FP1 nor IC2FP2 is reverse phase
- The input signal is valid at the rising edge and falling edge
- Enable the counter

Figure 83 Counter Operation Example in Encoder Mode

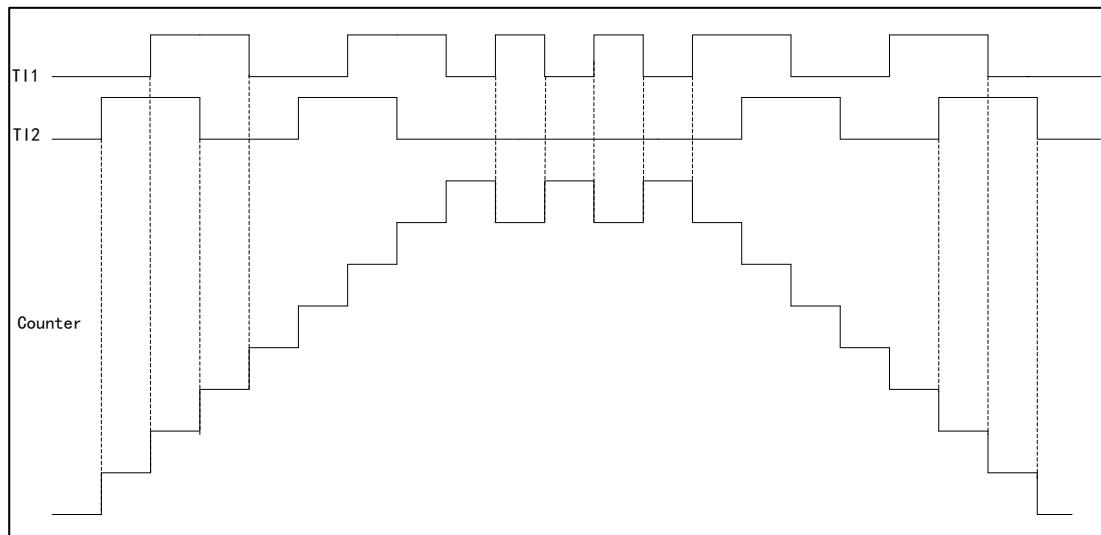

For example, when T11 is at low level, and T12 is in rising edge state, the counter will count up.

Figure 84 Example of Encoder Interface Mode of IC1FP1 Reversed Phase

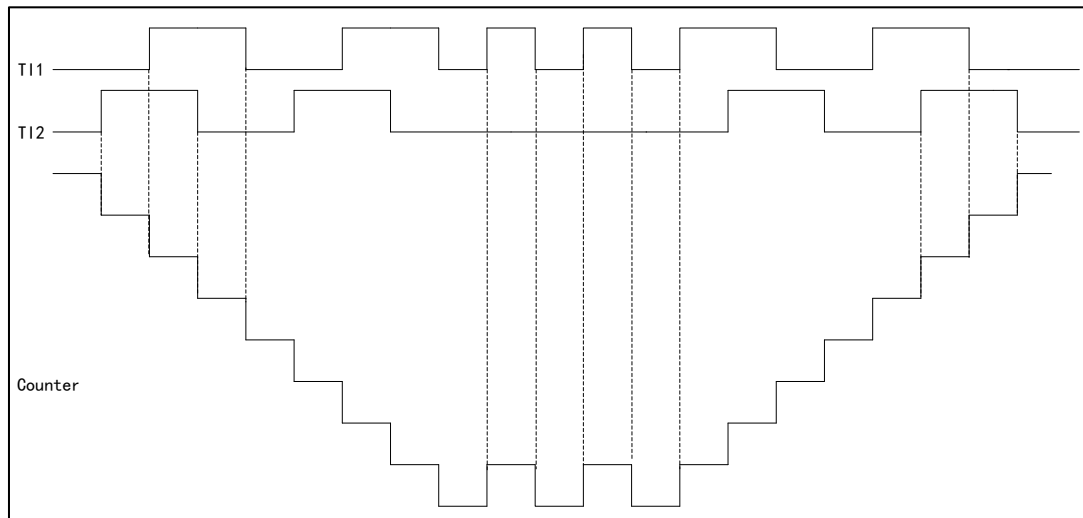

For example, when T11 is at low level, and the rising edge of T12 jumps, the counter will count down.

18.4.13 Slave Mode

TMR1 timer can synchronize external trigger

- Reset mode
- Gated mode
- Trigger mode

SMFSEL bit in TMR1_SMCTRL register can be set to select the mode

SMFSEL=100 set the reset mode, SMFSEL=101 set the gated mode, SMFSEL=110 set the trigger mode.

In the reset mode, when a trigger input event occurs, the counter and prescaler will be initialized, and the rising edge of the selected trigger input (TRGI) will reinitialize the counter and generate a signal to update the register.

In the gated mode, the enable of the counter depends on the high level of the selected input. When the trigger input is high, the clock of the counter will be started. Once the trigger input becomes low, the counter will stop (but not be reset). The start and stop of the counter are controlled.

In the trigger mode, the enable of the counter depends on the event on the selected input, the counter is started (but is not reset) at the rising edge of the trigger input, and only the start of the counter is controlled.

18.4.14 Timer Interconnection

Each timer of TMR1 can be connected with each other to realize synchronization or cascading between timers. It is required to configure one timer in master mode and the other timer in slave mode.

When the timer is in master mode, it can reset, start, stop and provide clock source for the counter of the slave mode timer.

Figure 85 Timer 1 Master/Slave Mode Example

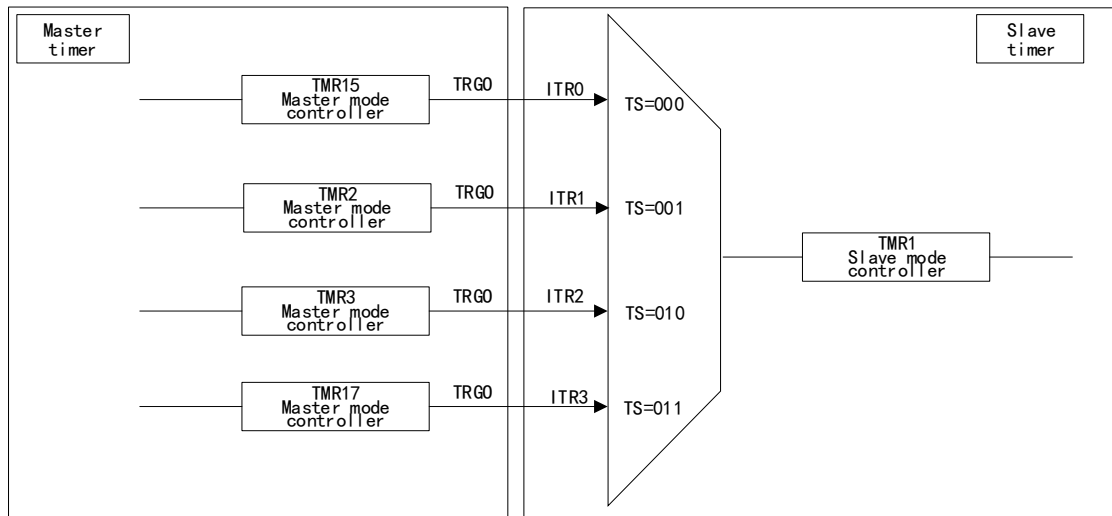

When the timers are interconnected:

- A timer can be used as the prescaler of other register
- Another register can be started by the enable signal of a timer
- Another register can be started by the update event of a timer
- Another register can be selected by the enable of a timer
- Two timers can be synchronized by an external trigger

18.4.15 Interrupt and DMA Request

The timer can generate an interrupt when an event occurs during operation

- Update event (counter overrun/underrun, counter initialization)
- Trigger event (counter start, stop, internal/external trigger)
- Capture/Compare event
- Breaking signal input event.

Some internal interrupt events can generate DMA requests, and special interfaces can enable or disable DMA requests.

18.4.16 Clear OCxREF Signal when External Events Occur

This function is used for output compare and PWM mode.

In one channel, the high level of ETRF input port will reduce the signal of OCxREF to low level, and the OCxCEN bit in capture/compare register TMR1_CCMx is set to 1, and OCxREF signal will remain low until the next update event.

Set TMR1 to PWM mode, close the external trigger prescaler, and disable the external trigger mode 2; when ETRF input is high, set OCxCEN=0, and the output OCxREF signal is shown in the figure below.

Figure 86 OCxREF Timing Diagram

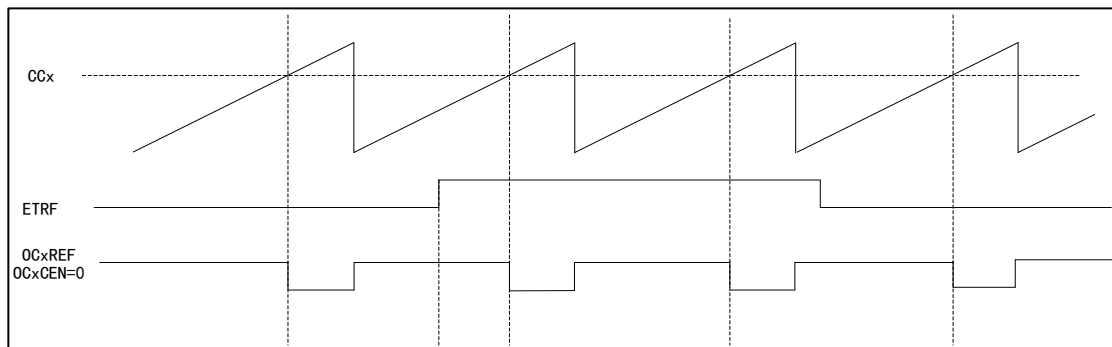

Set TMR1 to PWM mode, close the external trigger prescaler, and disable the external trigger mode 2; when ETRF input is high, set OCxCEN=1, and the output OCxREF signal is shown in the figure below.

Figure 87 OCxREF Timing Diagram

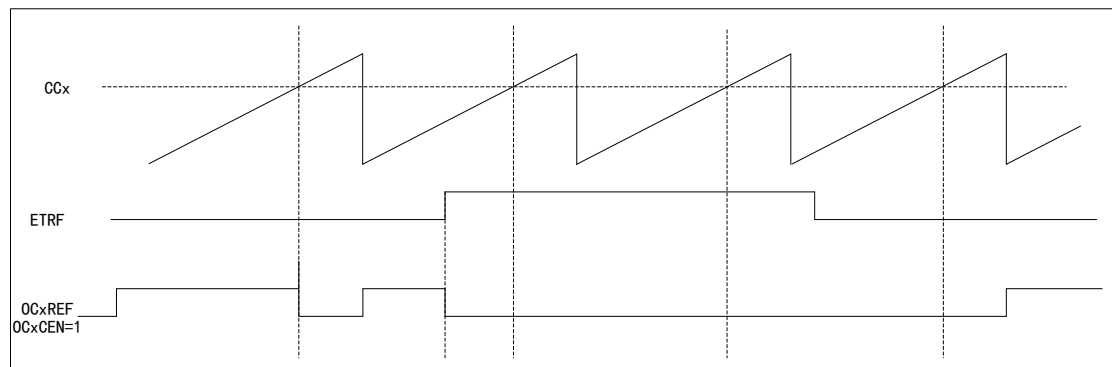

18.5 Register Address Mapping

In the following table, all registers of the advanced timer are mapped to a 16-bit addressable (address) space.

Table 57 TMR1 Register Address Mapping

Register name	Description	Offset address
TMR1_CTRL1	Control register 1	0x00
TMR1_CTRL2	Control register 2	0x04
TMR1_SMCTRL	Slave mode control register	0x08
TMR1_DIEN	DMA/Interrupt enable register	0x0C
TMR1_STS	State register	0x10
TMR1_CEG	Control event generation register	0x14
TMR1_CCM1	Capture/Compare mode register 1	0x18
TMR1_CCM2	Capture/Compare mode register 2	0x1C

Register name	Description	Offset address
TMR1_CCEN	Capture/Compare enable register	0x20
TMR1_CNT	Counter register	0x24
TMR1_PSC	Prescaler register	0x28
TMR1_AUTORLD	Auto reload register	0x2C
TMR1_REPCNT	Repeat count register	0x30
TMR1_CC1	Channel 1 capture/compare register	0x34
TMR1_CC2	Channel 2 capture/compare register	0x38
TMR1_CC3	Channel 3 capture/compare register	0x3C
TMR1_CC4	Channel 4 capture/compare register	0x40
TMR1_BDT	Break and dead-time register	0x44
TMR1_DCTRL	DMA control register	0x48
TMR1_DMADDR	DMA address register of continuous mode	0x4C

18.6 Register Functional Description

18.6.1 Control register 1 (TMR1_CTRL1)

Offset address: 0x00

Reset value: 0x0000

Field	Name	R/W	Description
0	CNTEN	R/W	Counter Enable 0: Disable 1: Enable When the timer is configured as external clock, gated mode and encoder mode, it is required to write 1 to the bit by software to start regular work; when it is configured as the trigger mode, it can be written to 1 by hardware.
1	UD	R/W	Update Disable Update event can cause AUTORLD, PSC and CCx to generate the value of update setting. 0: Update event is allowed (UEV) An update event can occur in any of the following situations: The counter overruns/underruns; Set UEG bit; Update generated by slave mode controller. 1: Update event is disabled
2	URSSEL	R/W	Update Request Source Select If interrupt or DMA is enabled, the update event can generate update interrupt or DMA request. Different update request sources can be selected through this bit. 0: The counter overruns or underruns Set UEG bit Update generated by slave mode controller 1: The counter overruns or underruns
3	SPMEN	R/W	Single Pulse Mode Enable When an update event is generated, the output level of the channel can be changed; in this mode, the CNTEN bit will be cleared, the counter will be stopped, and the output level of the channel will not be changed. 0: Disable 1: Enable

Field	Name	R/W	Description
4	CNTDIR	R/W	Counter Direction This bit is read-only when the counter is configured as center alignment mode or encoder mode. 0: Count up 1: Count down
6:5	CAMSEL	R/W	Center Aligned Mode Select In the center alignment mode, the counter counts up and down alternately; otherwise, it will only count up or down. Different center alignment modes affect the timing of setting the output compare interrupt flag bit of the output channel to 1; when the counter is disabled (CNTEN=0), select the center alignment mode. 00: Edge alignment mode 01: Center alignment mode 1 (the output compare interrupt flag bit of output channel is set to 1 when counting down) 10: Center alignment mode 2 (the output compare interrupt flag bit of output channel is set to 1 when counting up) 11: Center alignment mode 3 (the output compare interrupt flag bit of output channel is set to 1 when counting up/down)
7	ARPEN	R/W	Auto-reload Preload Enable When the buffer is disabled, the program modification TMR1_AUTORLD will immediately modify the values loaded to the counter; when the buffer is enabled, the program modification TMR1_AUTORLD will modify the values loaded to the counter in the next update event. 0: Disable 1: Enable
9:8	CLKDIV	R/W	Clock Divide Factor For the configuration of dead time and digital filter, CK_INT provides the clock, and the dead time and the clock of the digital filter can be adjusted by setting this bit. 00: $t_{DTS}=t_{CK_INT}$ 01: $t_{DTS}=2 \times t_{CK_INT}$ 10: $t_{DTS}=4 \times t_{CK_INT}$ 11: Reserved
15:10	Reserved		

18.6.2 Control register 2 (TMR1_CTRL2)

Offset address: 0x04

Reset value: 0x0000

Field	Name	R/W	Description
0	CCPEN	R/W	Capture/Compare Preloaded Enable This bit affects the change of CCxEN, CCxNEN and OCxMOD values. When preloading is disabled, the program modification will immediately affect the timer setting; When preloading is enabled, it is only updated after COMG is set, so as to affect the setting of timer; this bit only works on channels with complementary output. 0: Disable 1: Enable
1	Reserved		
2	CCUSEL	R/W	Capture/compare Control Update Select Only when the capture/compare preload is enabled (CCPEN=1), it works only for complementary output channel. 0: It can only be updated by setting COMG bit 1: It can be updated by setting COMG bit or rising edge on TRGI
3	CCDSEL	R/W	Capture/compare DMA Select 0: Transmit DMA request of CCx when CCx event occurs 1: Transmit DMA request of CCx when an update event occurs

Field	Name	R/W	Description
6:4	MMSEL	R/W	<p>Master Mode Signal Select</p> <p>The signals of timers working in master mode can be used for TRGO, which affects the work of timers in slave mode and cascaded with master timer, and specifically affects the configuration of timers in slave mode.</p> <p>000: Reset; the reset signal of master mode timer is used for TRGO 001: Enable; the counter enable signal of master mode timer is used for TRGO 010: Update; the update event of master mode timer is used for TRGO 011: Compare pulses; when the master mode timer captures/compares successfully (CCxIFLG=1), a pulse signal is output for TRGO 100: Compare mode 1; OC1REF is used to trigger TRGO 101: Compare mode 2; OC2REF is used to trigger TRGO 110: Compare mode 3; OC3REF is used to trigger TRGO 111: Compare mode 4; OC4REF is used to trigger TRGO</p>
7	TI1SEL	R/W	<p>Timer Input 1 Select</p> <p>0: TMR1_CH1 pin is connected to TI1 input 1: TMR1_CH1, TMR1_CH2 and TMR1_CH3 pins are connected to TI1 input after exclusive</p>
8	OC1OIS	R/W	<p>OC1 Output Idle State Configure</p> <p>Only the level state after the dead time of OC1 is affected when MOEN=0 and OC1N is realized.</p> <p>0: OC1=0 1: OC1=1</p> <p>Note: When LOCKCFG bit in TMR1_BDT register is at the Level 1, 2 or 3, this bit cannot be modified.</p>
9	OC1NOIS	R/W	<p>OC1N Output Idle State Configure</p> <p>Only the level state after the dead time of OC1 is affected when MOEN=0 and OC1N is realized.</p> <p>0: OC1N=0 1: OC1N=1</p> <p>Note: When LOCKCFG bit in TMR1_BDT register is at the Level 1, 2 or 3, this bit cannot be modified.</p>
10	OC2OIS	R/W	Configure OC2 output idle state. Refer to OC1OIS bit
11	OC2NOIS	R/W	Configure OC2N output idle state. Refer to OC1NOIS bit
12	OC3OIS	R/W	Configure OC3 output idle state. Refer to OC1OIS bit
13	OC3NOIS	R/W	Configure OC3N output idle state. Refer to OC1NOIS bit
14	OC4OIS	R/W	Configure OC4 output idle state. Refer to OC1OIS bit
15	Reserved		

18.6.3 Slave mode control register (TMR1_SMCTRL)

Offset address: 0x08

Reset value: 0x0000

Field	Name	R/W	Description
2:0	SMFSEL	R/W	<p>Slave Mode Function Select</p> <p>000: Disable the slave mode, the timer can be used as master mode timer to affect the work of slave mode timer; if CTRL1_CNTEN=1, the prescaler is directly driven by the internal clock.</p> <p>001: Encoder mode 1; according to the level of TI1FP1, the counter counts at the edge of TI2FP2.</p> <p>010: Encoder mode 2; according to the level of TI2FP2, the counter counts at the edge of TI1FP1.</p> <p>011: Encoder mode 3; according to the input level of another signal, the counter counts at the edge of TI1FP1 and TI2FP2.</p> <p>100: Reset mode; the slave mode timer resets the counter after receiving the</p>

Field	Name	R/W	Description
			<p>rising edge signal of TRGI and generates the signal to update the register.</p> <p>101: Gated mode; the slave mode timer starts the counter to work after receiving the TRGI high level signal; it stops the counter when receiving TRGI low level; when receiving TRGI high level signal again, the timer will continue to work; the counter is not reset during the whole period.</p> <p>110: Trigger mode, the slave mode timer starts the counter to work after receiving the rising edge signal of TRGI.</p> <p>111: External clock mode 1; select the rising edge signal of TRGI as the clock source to drive the counter to work.</p>
3	OCCSEL	R/W	<p>OCREF Clear Source Select</p> <p>This bit is used to select OCREF clear source</p> <p>0: OCREF_CLR</p> <p>1: ETRF</p>
6:4	TRGSEL	R/W	<p>Trigger Input Signal Select</p> <p>In order to avoid false edge detection when changing the bit value, it must be changed when SMFSEL=0.</p> <p>000: Internal trigger ITR0</p> <p>001: Internal trigger ITR1</p> <p>010: Internal trigger ITR2</p> <p>011: Internal trigger ITR3</p> <p>100: Channel 1 input edge detector TIF_ED</p> <p>101: Channel 1 post-filtering timer input TI1FP1</p> <p>110: Channel 2 post-filtering timer input TI2FP2</p> <p>111: External trigger input (ETRF)</p>
7	MSMEN	R/W	<p>Master/slave Mode Enable</p> <p>0: Invalid</p> <p>1: Enable the master/slave mode</p>
11:8	ETFCFG	R/W	<p>External Trigger Filter Configure</p> <p>0000: Filter disabled, sampling by f_{DTS}</p> <p>0001: DIV=1, N=2</p> <p>0010: DIV=1, N=4</p> <p>0011: DIV=1, N=8</p> <p>0100: DIV=2, N=6</p> <p>0101: DIV=2, N=8</p> <p>0110: DIV=4, N=6</p> <p>0111: DIV=4, N=8</p> <p>1000: DIV=8, N=6</p> <p>1001: DIV=8, N=8</p> <p>1010: DIV=16, N=5</p> <p>1011: DIV=16, N=6</p> <p>1100: DIV=16, N=8</p> <p>1101: DIV=32, N=5</p> <p>1110: DIV=32, N=6</p> <p>1111: DIV=32, N=8</p> <p>Sampling frequency=timer clock frequency/DIV; the filter length=N, and a jump is generated by every N events.</p>
13:12	ETPCFG	R/W	<p>External Trigger Prescaler Configure</p> <p>The ETR (external trigger input) signal becomes ETRP after frequency division. The signal frequency of ETRP is at most 1/4 of TMR1CLK frequency; when ETR frequency is too high, the ETRP frequency must be reduced through frequency division.</p> <p>00: The prescaler is disabled</p> <p>01: ETR signal 2 divided frequency</p> <p>10: ETR signal 4 divided frequency</p>

Field	Name	R/W	Description
			11: ETR signal 8 divided frequency
14	ECEN	R/W	External Clock Enable Mode2 0: Disable 1: Enable Setting ECEN bit has the same function as selecting external clock mode 1 to connect TRGI to ETRF; slave mode (reset, gating, trigger) can be used at the same time with external clock mode 2, but TRGI cannot be connected to ETRF in such case; when external clock mode 1 and external clock mode 2 are enabled at the same time, the input of external clock is ETRF.
15	ETPOL	R/W	External Trigger Polarity Configure This bit decides whether the external trigger ETR is reversed. 0: The external trigger ETR is not reversed, and the high level or rising edge is valid 1: The external trigger ETR is reversed, and the low level or falling edge is valid

Table 58 TMR1 Internal Trigger Connection

Slave timer	ITR0 (TS=00)	ITR1 (TS=001)	ITR2 (TS=010)	ITR3 (TS=011)
TMR1	TMR15	TMR2	TMR3	TMR17

18.6.4 DMA/Interrupt enable register (TMR1_DIEN)

Offset address: 0x0C

Reset value: 0x0000

Field	Name	R/W	Description
0	UIEN	R/W	Update interrupt Enable 0: Disable 1: Enable
1	CC1IEN	R/W	Capture/Compare Channel1 Interrupt Enable 0: Disable 1: Enable
2	CC2IEN	R/W	Capture/Compare Channel2 Interrupt Enable 0: Disable 1: Enable
3	CC3IEN	R/W	Capture/Compare Channel3 Interrupt Enable 0: Disable 1: Enable
4	CC4IEN	R/W	Capture/Compare Channel4 Interrupt Enable 0: Disable 1: Enable
5	COMIEN	R/W	COM Interrupt Enable 0: Disable 1: Enable
6	TRGIEN	R/W	Trigger interrupt Enable 0: Disable 1: Enable
7	BRKIEN	R/W	Break interrupt Enable 0: Disable 1: Enable

Field	Name	R/W	Description
8	UDIEN	R/W	Update DMA Request Enable 0: Disable 1: Enable
9	CC1DEN	R/W	Capture/Compare Channel1 DMA Request Enable 0: Disable 1: Enable
10	CC2DEN	R/W	Capture/Compare Channel2 DMA Request Enable 0: Disable 1: Enable
11	CC3DEN	R/W	Capture/Compare Channel3 DMA Request Enable 0: Disable 1: Enable
12	CC4DEN	R/W	Capture/Compare Channel4 DMA Request Enable 0: Disable 1: Enable
13	COMDEN	R/W	COM DMA Request Enable 0: Disable 1: Enable
14	TRGDEN	R/W	Trigger DMA Request Enable 0: Disable 1: Enable
15	Reserved		

18.6.5 State register (TMR1_STS)

Offset address: 0x10

Reset value: 0x0000

Field	Name	R/W	Description
0	UIFLG	RC_W0	Update Event Interrupt Generate Flag 0: Update event interrupt does not occur 1: Update event interrupt occurs When the counter value is reloaded or reinitialized, an update event will be generated. The bit is set to 1 by hardware and cleared by software; update events are generated in the following situations: (1) UD=0 on TMR1_CTRL1 register, and when the value of the repeat counter overruns/underruns, an update event will be generated; (2) URSSEL=0 and UD=0 on TMR1_CTRL1 register, configure UEG = 1 on TMR1_CEG register to generate update event, and the counter needs to be initialized by software; (3) URSSEL=0 and UD=0 on TMR1_CTRL1 register, generate update event when the counter is initialized by trigger event.
1	CC1IFLG	RC_W0	Capture/Compare Channel1 Interrupt Flag When the capture/compare channel 1 is configured as output: 0: No matching occurred 1: The value of TMR1_CNT matches the value of TMR1_CC1 When the capture/compare channel 1 is configured as input: 0: Input capture did not occur 1: Input capture occurred It is set to 1 by hardware when a capture event occurs, and can be cleared by software or by reading TMR1_CC1 register.

Field	Name	R/W	Description
2	CC2IFLG	RC_W0	Captuer/Compare Channel2 Interrupt Flag Refer to STS_CC1IFLG
3	CC3IFLG	RC_W0	Capture/Compare Channel3 Interrupt Flag Refer to STS_CC1IFLG
4	CC4IFLG	RC_W0	Captuer/Compare Channel4 Interrupt Flag Refer to STS_CC1IFLG
5	COMIFLG	RC_W0	COM Event Interrupt Generate Flag 0: COM event does not occur 1: COM interrupt waits for response After COM event is generated, this bit is set to 1 by hardware and cleared by software.
6	TRGIFLG	RC_W0	Trigger Event Interrupt Generate Flag 0: Trigger event interrupt did not occur 1: Trigger event interrupt occurred After Trigger event is generated, this bit is set to 1 by hardware and cleared by software.
7	BRKIFLG	RC_W0	Break Event Interrupt Generate Flag 0: Break event does not occur 1: Break event occurs When break input is valid, this bit is set to 1 by hardware; when break input is invalid, this bit can be cleared by software.
8	Reserved		
9	CC1RCFLG	RC_W0	Capture/compare Channel1 Repetition Capture Flag 0: Repeat capture does not occur 1: Repeat capture occurs The value of the counter is captured to TMR1_CC1 register, and CC1IFLG=1; this bit is set to 1 by hardware and cleared by software only when the channel is configured as input capture.
10	CC2RCFLG	RC_W0	Capture/compare Channel2 Repetition Capture Flag Refer to STS_CC1RCFLG
11	CC3RCFLG	RC_W0	Capture/compare Channel3 Repetition Capture Flag Refer to STS_CC1RCFLG
12	CC4RCFLG	RC_W0	Capture/compare Channel4 Repetition Capture Flag Refer to STS_CC1RCFLG
15:13	Reserved		

18.6.6 Control event generation register (TMR1_CEG)

Offset address: 0x14

Reset value: 0x0000

Field	Name	R/W	Description
0	UEG	W	Update Event Generate 0: Invalid 1: Initialize the counter and generate the update event This bit is set to 1 by software, and cleared by hardware. Note: When an update event is generated, the counter of the prescaler will be cleared, but the prescaler factor remains unchanged. In count-down mode, the counter will read the value of TMR1_AUTORLD; in center alignment mode or count-up mode, the counter will be cleared.

Field	Name	R/W	Description
1	CC1EG	W	Capture/Compare Channel1 Event Generation 0: Invalid 1: Capture/Compare event is generated This bit is set to 1 by software and cleared automatically by hardware. If Channel 1 is in output mode: When CC1IFLG=1, if CC1IEN and CC1DEN bits are set, the corresponding interrupt and DMA request will be generated. If Channel 1 is in input mode: The value of the capture counter is stored in TMR1_CC1 register; configure CC1IFLG=1, and if CC1IEN and CC1DEN bits are also set, the corresponding interrupt and DMA request will be generated; at this time, if CC1IFLG=1, it is required to configure CC1RCFLG=1.
2	CC2EG	W	Capture/Compare Channel2 Event Generation Refer to CC1EG description
3	CC3EG	W	Capture/Compare Channel3 Event Generation Refer to CC1EG description
4	CC4EG	W	Capture/Compare Channel4 Event Generation Refer to CC1EG description
5	COMG	W	Capture/Compare Control Update Event Generate 0: Invalid 1: Capture/Compare update event is generated This bit is set to 1 by software and cleared automatically by hardware. Note: COMG bit is valid only in complementary output channel.
6	TEG	W	Trigger Event Generate 0: Invalid 1: Trigger event is generated This bit is set to 1 by software and cleared automatically by hardware.
7	BEG	W	Break Event Generate 0: Invalid 1: Break event is generated This bit is set to 1 by software and cleared automatically by hardware.
15:8	Reserved		

18.6.7 Capture/Compare mode register 1 (TMR1_CCM1)

Offset address: 0x18

Reset value: 0x0000

The timer can be configured as input (capture mode) or output (compare mode) by CCxSEL bit. The functions of other bits of the register are different in input and output modes, and the functions of the same bit are different in output mode and input mode. The OCxx in the register describes the function of the channel in the output mode, and the ICxx in the register describes the function of the channel in the input mode.

Output compare mode:

Field	Name	R/W	Description
1:0	CC1SEL	R/W	Capture/Compare Channel 1 Select This bit defines the input/output direction and the selected input pin. 00: CC1 channel is output 01: CC1 channel is input, and IC1 is mapped on TI1 10: CC1 channel is input, and IC1 is mapped on TI2

Field	Name	R/W	Description
			11: CC1 channel is input, and IC1 is mapped on TRC, and only works in internal trigger input Note: This bit can be written only when the channel is closed (TMR1_CCEN register CC1EN=0).
2	OC1FEN	R/W	Output Compare Channel1 Fast Enable 0: Disable 1: Enable This bit is used to improve the response of the capture/compare output to the trigger input event.
3	OC1PEN	R/W	Output Compare Channel1 Preload Enable 0: Preloading function is disabled; write the value of TMR1_CC1 register through the program and it will work immediately. 1: Preloading function is enabled; write the value of TMR1_CC1 register through the program and it will work after an update event is generated. Note: When the protection level is 3 and the channel is configured as output, this bit cannot be modified. When the preload register is uncertain, PWM mode can be used only in single pulse mode (SPMEN=1); otherwise, the following output compare result is uncertain.
6:4	OC1MOD	R/W	Output Compare Channel1 Mode Configure 000: Freeze The output compare has no effect on OC1REF 001: The output value is high when matching. When the value of counter CNT matches the value CCx of capture/compare register, OC1REF will be forced to be at high level 010: The output value is low when matching. When the value of the counter matches the value of the capture/compare register, OC1REF will be forced to be at low level 011: Output flaps when matching. When the value of the counter matches the value of the capture/compare register, flap the level of OC1REF 100: The output is forced to be low Force OC1REF to be at low level 101: The output is forced to be high. Force OC1REF to be at high level 110: PWM mode 1 (set to high when the counter value < output compare value; otherwise, set to low) 111: PWM mode 2 (set to high when the counter value > output compare value; otherwise, set to low) Note: When the protection level is 3 and the channel is configured as output, this bit cannot be modified. In PWM modes 1 and 2, the OC1REF level changes when the compare result changes or when the output compare mode changes from freeze mode to PWM mode.
7	OC1CEN	R/W	Output Compare Channel1 Clear Enable 0: OC1REF is unaffected by ETRF input. 1: When high level of ETRF input is detected, OC1REF=0
9:8	CC2SEL	R/W	Capture/Compare Channel2 Select This bit defines the input/output direction and the selected input pin. 00: CC2 channel is output 01: CC2 channel is input, and IC2 is mapped on TI2 10: CC2 channel is input, and IC2 is mapped on TI1 11: CC2 channel is input, and IC2 is mapped on TRC, and only works in internal trigger input Note: This bit can be written only when the channel is closed (TMR1_CCEN register CC2EN=0).
10	OC2FEN	R/W	Output Compare Channel2 Preload Enable
11	OC2PEN	R/W	Output Compare Channel2 Buffer Enable
14:12	OC2MOD	R/W	Output Compare Channel1 Mode
15	OC2CEN	R/W	Output Compare Channel2 Clear Enable

Input capture mode:

Field	Name	R/W	Description
-------	------	-----	-------------

Field	Name	R/W	Description
1:0	CC1SEL	R/W	Capture/Compare Channel 1 Select 00: CC1 channel is output 01: CC1 channel is input, and IC1 is mapped on T11 10: CC1 channel is input, and IC1 is mapped on T12 11: CC1 channel is input, and IC1 is mapped on TRC, and only works in internal trigger input Note: This bit can be written only when the channel is closed (TMR1_CCEN bit CC1EN=0).
3:2	IC1PSC	R/W	Input Capture Channel 1 Prescaler Configure 00: PSC=1 01: PSC=2 10: PSC=4 11: PSC=8 PSC is prescaled factor, which triggers capture once every PSC events.
7:4	IC1F	R/W	Input Capture Channel 1 Filter Configure 0000: Filter disabled, sampling by f_{DTS} 0001: DIV=1, N=2 0010: DIV=1, N=4 0011: DIV=1, N=8 0100: DIV=2, N=6 0101: DIV=2, N=8 0110: DIV=4, N=6 0111: DIV=4, N=8 1000: DIV=8, N=6 1001: DIV=8, N=8 1010: DIV=16, N=5 1011: DIV=16, N=6 1100: DIV=16, N=8 1101: DIV=32, N=5 1110: DIV=32, N=6 1111: DIV=32, N=8 Sampling frequency=timer clock frequency/DIV; the filter length=N, indicating that a jump is generated by every N events.
9:8	CC2SEL	R/W	Capture/Compare Channel 2 Select 00: CC2 channel is output 01: CC2 channel is input, and IC2 is mapped on T11 10: CC2 channel is input, and IC2 is mapped on T12 11: CC2 channel is input, and IC2 is mapped on TRC, and only works in internal trigger input Note: This bit can be written only when the channel is closed (TMR1_CCEN register CC2EN=0).
11:10	IC2PSC	R/W	Input Capture Channel 2 Prescaler Configure
15:12	IC2F	R/W	Input Capture Channel 2 Filter Configure

18.6.8 Capture/Compare mode register 2 (TMR1_CCM2)

Offset address: 0x1C

Reset value: 0x0000

Refer to the description of the above CCM1 register.

Output compare mode:

Field	Name	R/W	Description
1:0	CC3SEL	R/W	Capture/Compare Channel 1 Select This bit defines the input/output direction and the selected input pin. 00: CC3 channel is output 01: CC3 channel is input, and IC3 is mapped on T13 10: CC3 channel is input, and IC3 is mapped on T14

Field	Name	R/W	Description
			11: CC3 channel is input, and IC3 is mapped on TRC, and only works in internal trigger input Note: This bit can be written only when the channel is closed (TMR1_CCEN register CC3EN=0).
2	OC3FEN	R/W	Output Compare Channel3 Fast Enable 0: Disable 1: Enable This bit is used to improve the response of the capture/compare output to the trigger input event.
3	OC3PEN	R/W	Output Compare Channel3 Preload Enable
6:4	OC3MOD	R/W	Output Compare Channel3 Mode Configure
7	OC3CEN	R/W	Output Compare Channel3 Clear Enable 0: OC3REF is unaffected by ETRF input. 1: When high level of ETRF input is detected, OC1REF=0
9:8	CC4SEL	R/W	Capture/Compare Channel 4 Select This bit defines the input/output direction and the selected input pin. 00: CC4 channel is output 01: CC4 channel is input, and IC4 is mapped on TI4 10: CC4 channel is input, and IC4 is mapped on TI3 11: CC4 channel is input, and IC4 is mapped on TRC, and only works in internal trigger input Note: This bit can be written only when the channel is closed (TMR1_CCEN register CC4EN=0).
10	OC4FEN	R/W	Output Compare Channel4 Preload Enable
11	OC4PEN	R/W	Output Compare Channel4 Buffer Enable
14:12	OC4MOD	R/W	Output Compare Channel4 Mode Configure
15	OC4CEN	R/W	Output Compare Channel4 Clear Enable

Input capture mode:

Field	Name	R/W	Description
1:0	CC3SEL	R/W	Capture/Compare Channel 3 Select 00: CC3 channel is output 01: CC3 channel is input, and IC3 is mapped on TI3 10: CC3 channel is input, and IC3 is mapped on TI4 11: CC3 channel is input, and IC3 is mapped on TRC, and only works in internal trigger input Note: This bit can be written only when the channel is closed (TMR1_CCEN register CC3EN=0).
3:2	IC3PSC	R/W	Input Capture Channel 3 Prescaler Configure 00: PSC=1 01: PSC=2 10: PSC=4 11: PSC=8 PSC is prescaled factor, which triggers capture once every PSC events.
7:4	IC3F	R/W	Input Capture Channel 3 Filter Configure
9:8	CC4SEL	R/W	Capture/Compare Channel 4 Select 00: CC4 channel is output 01: CC4 channel is input, and IC4 is mapped on TI4 10: CC4 channel is input, and IC4 is mapped on TI3 11: CC4 channel is input, and IC4 is mapped on TRC, and only works in internal trigger input Note: This bit can be written only when the channel is closed (TMR1_CCEN register CC4EN=0).

Field	Name	R/W	Description
11:10	IC4PSC	R/W	Input Capture Channel 4 Perscaler Configure
15:12	IC4F	R/W	Input Capture Channel 4 Filter Configure

18.6.9 Capture/Compare enable register (TMR1_CCEN)

Offset address: 0x20

Reset value: 0x0000

Field	Name	R/W	Description
0	CC1EN	R/W	<p>Capture/Compare Channel1 Output Enable</p> <p>When CC1 is configured as output: 0: Output is disabled 1: Output is enabled</p> <p>When CC1 is configured as input: This bit determines whether the value CNT of the counter can capture and enter TMR1_CC1 register 0: Capture is disabled 1: Capture is enabled</p>
1	CC1POL	R/W	<p>Capture/Compare Channel1 Output Polarity Configure</p> <p>When CC1 channel is configured as output: 0: OC1 high level is valid 1: OC1 low level is valid</p> <p>When CC1 channel is configured as input: CC1POL and CC1NPOL control the polarity of the triggered or captured signals TI1FP1 and TI2FP1 at the same time 00: Non-phase-inverting/rising edge: TIxFP1 is not reversed phase (triggered in gated and encoder mode), and is captured at the rising edge of TIxFP1 (reset trigger, capture, external clock and trigger mode). 01: Inverted phase/Falling edge: TIxFP1 is reversed phase (triggered in gated and encoder mode), and is captured at the rising edge of TIxFP1 (reset trigger, capture, external clock and trigger mode). 10: Reserved 11: Non-phase-inverting/Rising and falling edges: TIxFP1 is not reversed phase (triggered in gated mode), and is captured at the rising edge of TIxFP1 (reset trigger, capture, external clock and trigger mode).</p>
2	CC1NEN	R/W	<p>Capture/Compare Channel1 Complementary Output Enable</p> <p>0: Disable 1: Enable</p>
3	CC1NPOL	R/W	<p>Capture/Compare Channel1 Complementary Output Polarity</p> <p>When CC1 channel is configured as output 0: OC1N high level is valid 1: OC1N low level is valid</p> <p>When CC1 channel is configured as input This bit, together with CC1POL, is used to define the polarity of TI1FP1 and TI2FP1</p> <p>Note: On the complementary output channel, if this bit is preloaded, and CCPEN=1 for TMR1_CTRL2, CC1NPOL can obtain new value from the preload bit only when reversing event is generated. When the protection level is 2 or 3, this bit cannot be modified</p>
4	CC2EN	R/W	<p>Capture/Compare Channel2 Output Enable</p> <p>Refer to CCEN_CC1EN</p>
5	CC2POL	R/W	<p>Capture/Compare Channel2 Output Polarity Configure</p> <p>Refer to CCEN_CC1POL</p>
6	CC2NEN	R/W	<p>Capture/Compare Channel1 Complementary Output Enable</p> <p>Refer to CCEN_CC1NEN</p>

Field	Name	R/W	Description
7	CC2NPOL	R/W	Capture/Compare Channel2 Complementary Output Polarity Configure Refer to CCEN_CC1NPOL
8	CC3EN	R/W	Capture/Compare Channel3 Output Enable Refer to CCEN_CC1EN
9	CC3POL	R/W	Capture/Compare Channel3 Output Polarity Configure Refer to CCEN_CC1POL
10	CC3NEN	R/W	Capture/Compare Channel3 Complementary Output Enable Refer to CCEN_CC1NEN
11	CC3NPOL	R/W	Capture/Compare Channel3 Complementary Output Polarity Configure Refer to CCEN_CC1NPOL
12	CC4EN	R/W	Capture/Compare Channel4 Output Enable Refer to CCEN_CC1EN
13	CC4POL	R/W	Capture/Compare Channel4 Output Polarity Refer to CCEN_CC1POL
15:14	Reserved		

18.6.10 Counter register (TMR1_CNT)

Offset address: 0x24

Reset value: 0x0000

Field	Name	R/W	Description
15:0	CNT	R/W	Counter Value

18.6.11 Prescaler register (TMR1_PSC)

Offset address: 0x28

Reset value: 0x0000

Field	Name	R/W	Description
15:0	PSC	R/W	Prescaler Value Clock frequency of counter (CK_CNT) = $f_{CK_PSC} / (PSC + 1)$

18.6.12 Auto reload register (TMR1_AUTORLD)

Offset address: 0x2C

Reset value: 0xFFFF

Field	Name	R/W	Description
15:0	AUTORLD	R/W	Auto Reload Value When the value of auto reload is empty, the counter will not count.

18.6.13 Repeat counter register (TMR1_REPCNT)

Offset address: 0x30

Reset value: 0x0000

Field	Name	R/W	Description
7:0	REPCNT	R/W	Repetition Counter Value When the count value of the repeat counter is reduced to 0, an update event will be generated, and the counter will start counting again from the REPCNT value; the new value newly written to this register is valid only when an update event occurs in next cycle.
15:8	Reserved		

18.6.14 Channel 1 capture/compare register (TMR1_CC1)

Offset address: 0x34

Reset value: 0x0000

Field	Name	R/W	Description
15:0	CC1	R/W	<p>Capture/Compare Channel 1 Value</p> <p>When the capture/compare channel 1 is configured as input mode: CC1 contains the counter value transmitted by the last input capture channel 1 event.</p> <p>When the capture/compare channel 1 is configured as output mode: CC1 contains the current load capture/compare register value</p> <p>Compare the value CC1 of the capture and compare channel 1 with the value CNT of the counter to generate the output signal on OC1.</p> <p>When the output compare preload is disabled (OC1PEN=0 for TMR1_CCM1 register), the written value will immediately affect the output compare results; If the output compare preload is enabled (TMR1_CCM1 register OC1PEN=1), the written value will affect the output compare result when an update event is generated.</p>

18.6.15 Channel 2 capture/compare register (TMR1_CC2)

Offset address: 0x38

Reset value: 0x0000

Field	Name	R/W	Description
15:0	CC2	R/W	<p>Capture/Compare Channel 2 Value</p> <p>Refer to TMR1_CC1</p>

18.6.16 Channel 3 capture/compare register (TMR1_CC3)

Offset address: 0x3C

Reset value: 0x0000

Field	Name	R/W	Description
15:0	CC3	R/W	<p>Capture/Compare Channel 3 Value</p> <p>Refer to TMR1_CC1</p>

18.6.17 Channel 4 capture/compare register (TMR1_CC4)

Offset address: 0x40

Reset value: 0x0000

Field	Name	R/W	Description
15:0	CC4	R/W	<p>Capture/Compare Channel 4 Value</p> <p>Refer to TMR1_CC1</p>

18.6.18 Break and dead-time register (TMR1_BDT)

Offset address: 0x44

Reset value: 0x0000

Note: According to the lock setting, AOEN, BRKPOL, BRKEN, IMOS, RMOS and DTS[7:0] bits all can be write-protected, and it is necessary to configure them when writing to TMR1_BDT register for the first time.

Field	Name	R/W	Description
7:0	DTS	R/W	<p>Dead Time Setup</p> <p>DT is the dead duration, and the relationship between DT and register DTS is as follows: $DTS[7:5]=0xx \Rightarrow DT=DTS[7:0] \times T_{DTS}$, $T_{DTS}=T_{DTS}$;</p>

Field	Name	R/W	Description
			$DTS[7:5]=10x \Rightarrow DT = (64 + DTS[5:0]) \times T_{DTS}$, $T_{DTS} = 2 \times T_{DTS}$; $DTS[7:5]=110 \Rightarrow DT = (32 + DTS[4:0]) \times T_{DTS}$, $T_{DTS} = 8 \times T_{DTS}$; $DTS[7:5]=111 \Rightarrow DT = (32 + DTS[4:0]) \times T_{DTS}$, $T_{DTS} = 16 \times T_{DTS}$; For example: assuming $T_{DTS} = 125ns$ (8MHZ), the dead time setting is as follows: If the step time is 125ns, the dead time can be set from 0 to 15875ns; If the step time is 250ns, the dead time can be set from 16us to 31750ns; If the step time is 1 μ s, the dead time can be set from 32 μ s to 63 μ s; If the step time is 2 μ s, the dead time can be set from 64 μ s to 126 μ s. Note: Once LOCK level (LOCKCFG bit in TMR1_BDT register) is set to 1, 2 or 3, these bits cannot be modified.
9:8	LOCKCFG	R/W	Lock Write Protection Mode Configure 00: Without Lock write protection level; the register can be written directly 01: Lock write protection level 1 It cannot be written to DTS, BRKEN, BRKPOL and AOEN bits of TMR1_BDT, and OCxOIS and OCxNOIS bits of TMR1_CTRL2 register. 10: Lock write protection level 2 It is not allowed to write to all bits with protection level 1 and write to the CCxPOL and OCxNPOL bits in TMR1_CCEN register and the RMOS and IMOS bits in TMR1_BDT register. 11: Lock write protection level 3 It is not allowed to write to all bits with protection level 2, and write to the OCxMOD and OCxPEN bits of TMR1_CCMx register. Note: After system reset, the lock write protect bit can only be written once.
10	IMOS	R/W	Idle Mode Off-state Configure Idle mode means MOEN=0; closed means CcxEN=0; this bit describes the impact of different values for this bit on the output waveform when MOEN=0 and CcxEN changes from 0 to 1. 0: OCx/OCxN output is disabled 1: If CCxEN=1, the invalid level is output during the dead time (the specific level value is affected by the polarity configuration), and the idle level is output after the dead time
11	RMOS	R/W	Run Mode Off-state Configure Run mode means MOEN=1; closed means CcxEN=0; this bit describes the impact of different values for this bit on the output waveform when MOEN=1 and CcxEN changes from 0 to 1. 0: OCx/OCxN output is disabled 1: OCx/OCxN first output invalid level (the specific level value is affected by the polarity configuration)
12	BRKEN	R/W	Break Function Enable 0: Disable 1: Enable Note: When the protection level is 1, this bit cannot be modified.
13	BRKPOL	R/W	Break Polarity Configure 0: The break input BRK is valid at low level 1: The break input BRK is valid at high level Note: When the protection level is 1, this bit cannot be modified. Writing to this bit requires an APB clock delay before it can be used.
14	AOEN	R/W	Automatic Output Enable 0: MOEN can only be set to 1 by software 1: MOEN can be set to 1 by software or be automatically set to 1 in next update event (breaking input is ineffective) Note: When the protection level is 1, this bit cannot be modified.
15	MOEN	R/W	PWM Main Output Enable 0: Disable the output of OCx and OCxN or force the output of idle state 1: When CCxEN and CCxNEN bits of the TMR1_CCEN register are set, turn on OCx and OCxN output When the break input is valid, it is cleared by hardware asynchronously. Note: Setting to 1 by software or setting to 1 automatically depends on AOEN bit of the TMR1_BDT register.

18.6.19 DMA control register (TMR1_DCTRL)

Offset address: 0x48

Reset value: 0x0000

Field	Name	R/W	Description
4:0	DBADDR	R/W	<p>DMA Base Address Setup</p> <p>These bits define the base address of DMA in continuous mode (when reading or writing TMR1_DMA register), and DBADDR is defined as the offset from the address of TMR1_CTRL1 register:</p> <p>00000: TMR1_CTRL1 00001: TMR1_CTRL2 00010: TMR1_SMCTRL </p>
7:5	Reserved		
12:8	DBLEN	R/W	<p>DMA Burst Transfer Length Setup</p> <p>These bits define the transfer length and transfer times of DMA in continuous mode. The data transferred can be 16 bits and 8 bits.</p> <p>When reading/writing TMR1_DMADDR register, the timer will conduct a continuous transmission;</p> <p>00000: Transmission for 1 time 00001: Transmission for 2 times 00010: Transmission for 3 times </p> <p>10001: Transmission for 18 times</p> <p>The transmission address formula is as follows: Transmission address=TMR1_CTRL1 address (slave address) +DBADDR+DMA index; DMA index=DBLEN</p> <p>For example: DBLEN=7, DBADDR=TMR1_CTRL1 (slave address) means the address of the data to be transmitted, while the address +DBADDR+7 of TMR1_CTRL1 means the address of the data to be written/read,</p> <p>Data transmission will occur to: TMR1_CTRL1 address + seven registers starting from DBADDR.</p> <p>The data transmission will change according to different DMA data length: When the transmission data is set to 16 bits, the data will be transmitted to seven registers When the transmission data is set to 8 bits, the data of the first register is the MSB bit of the first data, the data of the second register is the LSB bit of the first data, and the data will still be transmitted to seven registers.</p>
15:13	Reserved		

18.6.20 DMA address register of continuous mode (TMR1_DMADDR)

Offset address: 0x4C

Reset value: 0x0000

Field	Name	R/W	Description
-------	------	-----	-------------

Field	Name	R/W	Description
15:0	DMADDR	R/W	<p>DMA Register for Burst Transfer</p> <p>Read or write operation access of TMR1_DMADDR register may lead to access operation of the register in the following address: TMR1_CTRL1 address + (DBADDR+DMA index) ×4</p> <p>Wherein: “TMR1_CTRL1 address” is the address of control register 1 (TMR1_CTRL1); “DBADDR” is the base address defined in TMR1_DCTRL register; “DMA index” is the offset automatically controlled by DMA, and it depends on DBLEN defined in TMR1_DCTRL register.</p>

19 Infrared Timer (IRTMR)

19.1 Introduction

IRTMR is an infrared interface for remote control, which can use an infrared LED to realize remote control function.

19.2 Functional Description

19.2.1 IRTMR Receive

The infrared receiver can be connected to the GPIO of the controller or the input capture channel of the timer through the output of the external IR receiver module to realize data receiving.

19.2.2 IRTMR Transmit

IRTMR is internally connected to TMR16 and TMR17, and the specific block diagram is as follows:

Figure 88 IRTMR Structure Block Diagram

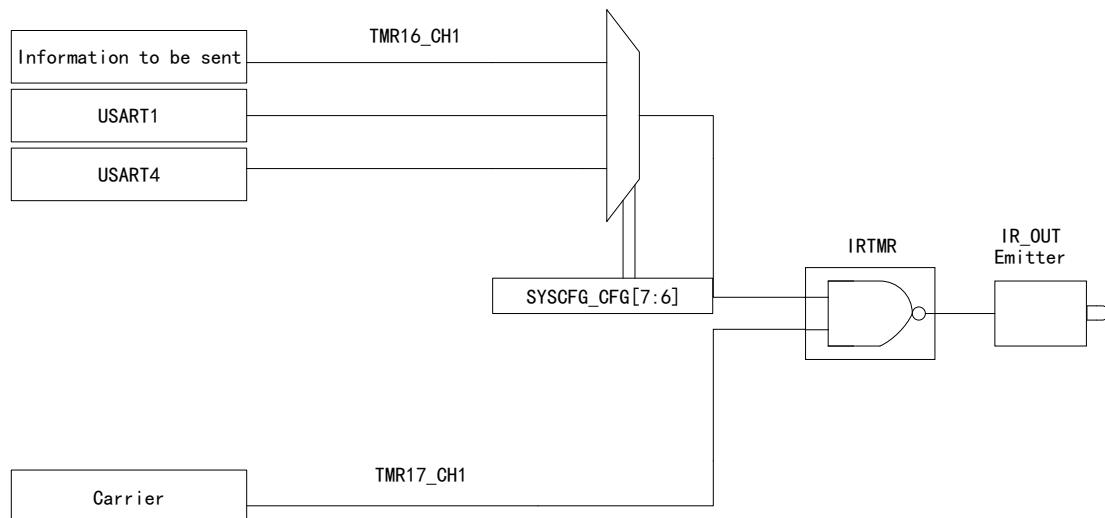

In order to generate correct infrared remote control signal, TMR17_CH1 should be configured correctly to provide a high-frequency carrier signal, while TMR16 only needs to provide the information we transmit.

The final modulation signal is output through IR_OUT pin, and this function is activated by enabling the related multiplexing functions in GPIOx_ALFx register.

20 Watchdog Timer (WDT)

20.1 Introduction

The watchdog is used to monitor system failures caused by software errors. There are two watchdog devices on the chip: independent watchdog and window watchdog, which improve the security, and make the time more accurate and the use more flexible.

The independent watchdog will reset when the counter decreases to 0, and when the value on the counter is outside the window value, it will be reset if it is reloaded.

The window watchdog will reset when the counter decreases to 0x3F. When the count value of the counter is before the window value of the configuration register, the refresh counter will also be reset.

20.2 Independent Watchdog

20.2.1 Introduction

The independent watchdog consists of an 8-bit prescaler IWDT_PSC, 12-bit count-down counter, 12-bit reload register IWDT_CNTRLD, key register IWDT_KEY, state register IWDT_STS and window register IWDT_WIN.

The independent watchdog has an independent clock source, and even if the master clock fails, it is still valid.

The independent watchdog is applicable to the situations where an independent environment is required but the accuracy requirement is not high.

20.2.2 Functional Block Diagram

Figure 89 Independent Watchdog Block Diagram

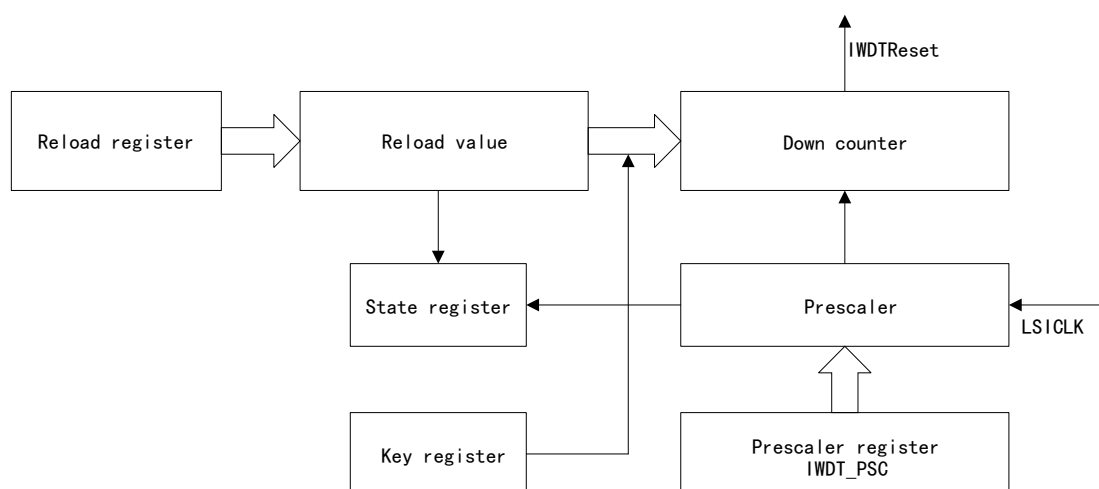

Note: The prescaler, reload value and count-down counter are in V_{DD} power supply area; the prescaler register, status register, reload register and key register are in 1.5V power supply area. The watchdog function is in the V_{DD} power supply area and it can work normally in the stop or standby mode.

20.2.3 Functional Description

20.2.3.1 Key register

Write 0xCCCC in the key register to enable the independent watchdog, then the counter starts to count down from the reset value 0xFFFF and when the counter counts to 0x000, a reset will be generated.

Write 0xAAAA in the key register, and the value of the reload register will be reloaded to the counter to prevent the watchdog from resetting.

Write 0X5555 in the key register to rewrite the value of the prescaler register, reload register and window value register.

20.2.3.2 Window register

The default value of Window register IWDT_WIN is 0xFFFF. In the case of no update, the window option is disabled. When the window value is changed, the reload operation will be performed, and the watchdog counter value will be set to the value of IWDT_CNTRLD, which can delay the event cycle needed for reset.

The independent watchdog can work in the window watchdog mode, and the value of window register IWDT_WIN needs to be set appropriately.

20.2.3.3 Configuration IWDT

Configuration IWDT when window register is used

- Enable IWDT (write 0xCCCC to the key register IWDT_KEY)
- Open the register access permission (write 0x5555 to the key register IWDT_KEY)
- Configure IWDT_PSC prescaler register (write the value within 0~7 to IWDT_PSC)
- The value of wait state register IWDT_STS is updated to 0x00
- Configuration window register IWDT_WIN (the value of auto reload register IWDT_CNTRLD can be updated to the watchdog register)

Note: When the value of state register IWDT_STS is 0x00, the window value will be written to refresh the counter with the value of auto reload

Configuration IWDT when window register is disabled

- Enable IWDT (write 0xCCCC to the key register IWDT_KEY)
- Open the register access permission (write 0x5555 to the key register IWDT_KEY)
- Configure IWDT_PSC prescaler register (write the value within 0~7 to IWDT_PSC)
- Configuration reload register IWDT_CNTRLD
- The value of wait state register IWDT_STS is updated to 0x00
- Use IWDT_CNTRLD register to referesh the watchdog counter

20.2.3.4 Regiser access protection

The prescaler register IWDT_PSC, reload register IWDT_CNTRLD and window register IWDT_WIN have the function of write protection. If you want to rewrite these three registers, you need to write 0X5555 in the key register. If you write other value in the key register, the protection of the register will be started again.

Write 0xAAAA to the key register and the write protection function will also be enabled.

The prescaler register, reload register and window register can be observed through the state register.

20.2.3.5 Hardware watchdog

After the “hardware watchdog” function is enabled, and the system is powered on and reset, the watchdog will run automatically. If 0xAAAA is not written to the key register, reset will be generated after the counter finishes counting.

20.2.3.6 Debug mode

The independent watchdog can be configured in debug mode and choose to stop or continue to work. It depends on the IWDT_STS bit of DBGMCU_APB1F register in DBGMCU module.

20.3 Window Watchdog

20.3.1 Introduction

The window watchdog contains a 7-bit free-running down counter, prescaler and control register WWDT_CTRL, configuration register WWDT_CFG and state register WWDT_STS.

The window watchdog clock comes from PCLK1, and the counter clock is obtained from the CK counter clock through frequency division by prescaler (configured by the configuration register).

The window watchdog is applicable when precise timing is needed.

20.3.2 Functional Block Diagram

Figure 90 Window Watchdog Function Block Diagram

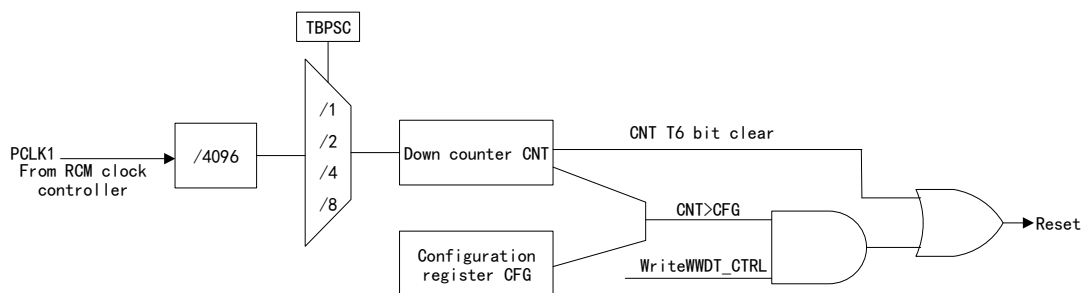

20.3.3 Functional Description

Enable window watchdog timer; the reset conditions are:

- When the counter count is less than 0x40, a reset will be generated.
- The reload counter will be reset before the counter counts to the value of the window register.

After reset, the watchdog is always closed and the watchdog can be enabled only by setting the WWDTEN bit of WWDT_CTRL register.

The counter of window watchdog is in free state. When the watchdog is disabled, the counter will continue to count down. The counter must be reloaded between the value of window register and 0x40 to avoid reset.

Setting the EWIE bit of the configuration register can enable the early wake-up interrupt. When the count reaches 0x40, the interrupt will be generated. Entering the interrupt service program (ISTS) can be used to prevent the window watchdog from resetting. EWIE interrupt can be cleared by writing 0 in the state register.

The unique window of the window watchdog timer can effectively monitor whether the program is faulty. For example, assuming that the running time of a program segment is T, and the value of the window register is slightly less than (TR-T), if there is no reload register in the window, it means that the program is faulty, and when the counter counts to 0x3F, it will generate reset.

Figure 91 Window Watchdog Timing Diagram

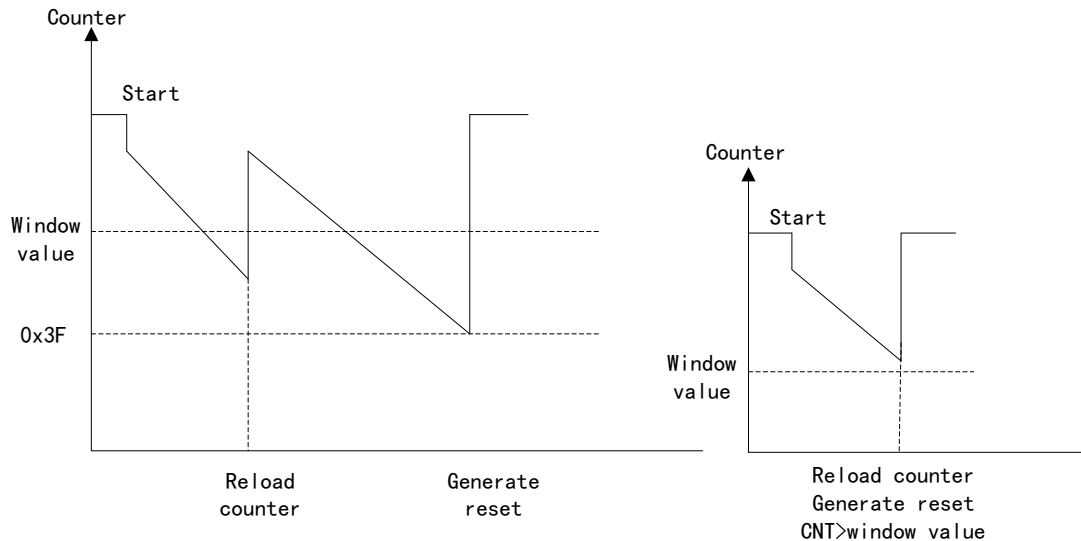

The calculation formula of window watchdog timer timeout is as follows:

$$T_{WWDt} = T_{PCLK1} \times 2^{WTB} \times (T[5:0] + 1)$$

Wherein:

- T_{WWDt} : WWDt timeout
- T_{PCLK1} : Clock cycle of APB1 in ms

Minimum/Maximum timeout when PCLK1=36MHZ

WTB	Minimum timeout value	Maximum timeout value
0	113μs	7.28ms
1	227μs	14.56ms
2	455μs	29.12ms
3	910μs	58.25ms

20.3.3.1 Debug mode

The window watchdog can be configured in debug mode and choose to stop or continue to work. It depends on the WWDt_STS bit of DBGMCU_APB1F register in DBGMCU module.

20.4 IWDT Register Address Mapping

Table 59 IWDT Register Mapping

Register name	Description	Offset address
IWDT_KEY	Key register	0x00

Register name	Description	Offset address
IWDT_PSC	Prescaler register	0x04
IWDT_CNTRL	Counter reload register	0x08
IWDT_STS	State register	0x0C
IWDT_WIN	Window register	0x10

20.5 IWDT Register Functional Description

These peripheral registers can be operated by half word (16 bits) or word (32 bits).

20.5.1 Key register (IWDT_KEY)

Offset address: 0x00

Reset value: 0x0000 0000 (reset in standby mode)

Field	Name	R/W	Description
15:0	KEY	W	<p>Allow Access IWDT Register Key Value</p> <p>Writing 0x5555 means enabled access to IWDT_PSC, IWDT_CNTRL and IWDT_WIN registers</p> <p>When the software writes 0xAAAA, it means to execute the reload counter, and a certain interval is required to prevent the watchdog from resetting.</p> <p>Write 0xCCCC and the watchdog will be enabled (the hardware watchdog is unrestricted by this command word).</p> <p>The read-out value is 0x0000.</p>
31:16	Reserved		

20.5.2 Prescaler register (IWDT_PSC)

Offset address: 0x04

Reset value: 0x0000 0000

Field	Name	R/W	Description
2:0	PSC	R/W	<p>Prescaler Factor Configure</p> <p>Support write protection function; when writing 0x5555 in the IWDT_KEY register, it is allowed to access the register; in the process of writing this register, only when IWDT_STS register PSCUFLG=0, can the prescaler factor be changed; in the process of reading this register, only when PSCUFLG=0, can the read-out value of PSC register be valid.</p> <p>000: PSC=4 001: PSC=8 010: PSC=16 011: PSC=32 100: PSC=64 101: PSC=128 110: PSC=256 111: PSC=256</p>
31:3	Reserved		

20.5.3 Counter reload register (IWDT_CNTRL)

Offset address: 0x08

Reset value: 0x0000 0FFF(reset in standby mode)

Field	Name	R/W	Description
-------	------	-----	-------------

Field	Name	R/W	Description
11:0	CNTRLD	R/W	<p>Watchdog Counter Reload Value Setup</p> <p>It supports write protection function and defines the value loaded to the watchdog counter when 0xAAAA is written by IWDT_KEY register; in the process of writing this register, this register can be modified only when CNTUFLG=0. In the process of reading this register, when CNTUFLG=0 in IWDT_STS register, the read value is valid.</p> <p>The watchdog timeout cycle can be calculated by the reload value and clock prescaled value.</p>
31:12	Reserved		

20.5.4 State register (IWDT_STS)

Offset address: 0x0C

Reset value: 0x0000 0000 (not reset in standby mode)

Field	Name	R/W	Description
0	PSCUFLG	R	<p>Watchdog Prescaler Value Update Flag</p> <p>When the prescaler factor is updated, it is set to 1 by hardware; after the prescaler factor is updated, the bit is cleared by hardware; the prescaler factor is updated only when the PSCUFLG bit is cleared.</p>
1	CNTUFLG	R	<p>Watchdog Counter Reload Value Update Flag</p> <p>When the counter reload value is updated, it is set to 1 by hardware; after the counter reload value is updated, the bit is cleared by hardware; the counter reload value is updated only when the CNTUFLG bit is cleared.</p>
2	WINUFLG	R	<p>Watchdog Counter Window Value Update Flag</p> <p>When the window value is updated, it is set to 1 by hardware; after the window value of the counter is updated, the bit is cleared by hardware; the window value is valid only when the IWDT_WIN register is enabled.</p>
31:3	Reserved		

20.5.5 Window register (IWDT_WIN)

Offset address: 0x10

Reset value: 0x0000 0FFF(reset in standby mode)

Field	Name	R/W	Description
11:0	WIN	R/W	<p>Watchdog Counter Window Value</p> <p>These bits include the window value and the initial value of down counter</p> <p>These bits can be modified only when STS_WINUFLG=0</p> <p>Reloading the counter between the counter value and the window value can prevent resetting</p> <p>Note: When reading this register, the value of V_{DD} power supply domain will be returned, so if you want to read data, you should ensure STS_WINUFLG=0.</p>
31:12	Reserved		

Note: When the reload setting, prescaler setting and window value resetting are running, if you want to change the reload value, prescaler value and window value, you need to confirm that the relevant flag bits are 0. There is no need to wait after the update, unless you want to enter the low-power mode.

20.6 WWDT Register Address Mapping

Table 60 WWDT Register Address Mapping

Register name	Description	Offset address
WWDT_CTRL	Control register	0x00
WWDT_CFG	Configuration register	0x04
WWDT_STS	State register	0x08

20.7 WWDT Register Functional Description

These peripheral registers can be operated by half word (16 bits) or word (32 bits).

20.7.1 Control register (WWDT_CTRL)

Offset address: 0x00

Reset value: 0x0000 007F

Field	Name	R/W	Description
6:0	CNT	R/W	Counter Value Setup This counter is 7 bits, and CNT6 is the most significant bit These bits are used to store the counter value of the watchdog. When the count value decreases from 0x40 to 0x3F, WWDT reset will be generated.
7	WWDTEN	R/S	Window Watchdog Enable This bit is set to 1 by software and can be cleared by hardware only after reset. When WWDTEN=1, WWDT can generate a reset. 0: Disable 1: Enable
31:8	Reserved		

20.7.2 Configuration register (WWDT_CFG)

Offset address: 0x04

Reset value: 0x0000 007F

Field	Name	R/W	Description
6:0	WIN	R/W	Window Value Setup This window value is 7 bits, which is used to compare with the down counter.
8:7	TBPSC	R/W	Timer Base Prescaler Factor Configure Divide the frequency on the basis of PCLK1/4096 00: No frequency division 01: 2-divided frequency 10: 4-divided frequency 11: 8-divided frequency
9	EWIEN	R/S	Early Wakeup Interrupt Enable 0: Meaningless 1: When the counter value reaches 0x40, an interrupt will be generated; this interrupt is cleared by hardware after reset.
31:10	Reserved		

20.7.3 State register (WWDT_STS)

Offset address: 0x08

Reset value: 0x0000 0000

Field	Name	R/W	Description
0	EWIFLG	RC_W0	<p>Early Wakeup Interrupt Occur Flag</p> <p>0: Not occur</p> <p>1: When the counter value reaches 0x40, it is set to 1 by hardware; if the interrupt is not enabled, the bit will also be set to 1.</p> <p>It can be cleared by writing 0 by software Writing 1 to this bit is invalid.</p>
31:1	Reserved		

21 Real-time Clock (RTC)

21.1 Full Name and Abbreviation Description of Terms

Table 61 Full Name and Abbreviation Description of Terms

Full name in English	English abbreviation
Second	SEC
Alarm	ALR
Prescaler	PSC

21.2 Introduction

It has sub-second, time and date registers with BCD coding, as well as corresponding alarm registers, and can realize timestamp function together with external pins. It supports clock calibration function and time compensation.

21.3 Main Characteristics

- Timebase unit
- Clock calibration
- Subsecond, time and date
- Time error compensation
- Alarm (subsecond, time and date mask)
- Timestamp
- Tamper detection
- 3 kinds of RTC outputs
- Backup domain
- Multiple interrupt control
- Automatic wakeup of low power

21.4 Structure Block Diagram

Figure 92 RTC Structure Block Diagram

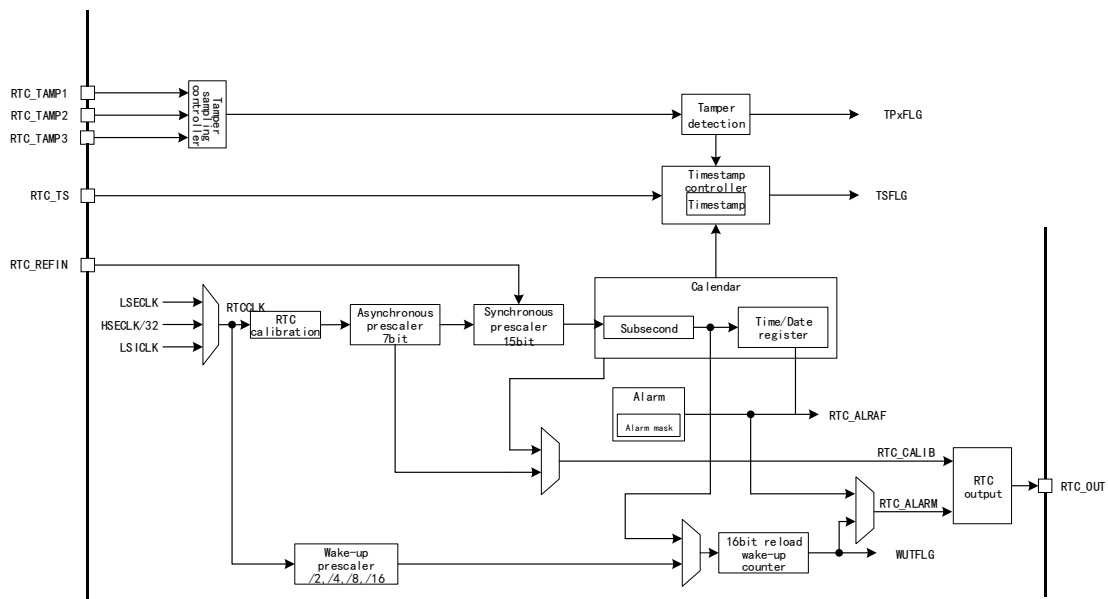

Note:

- (1) Alternate function output: RTC_OUT is output in one of the following two forms
- RTC_CALIB: This output is enabled through CALOEN bit of RTC_CTRL register, and when the frequency of LSECLK is 32.768kHz, the clock output is 512Hz or 1Hz.
 - RTC_ALARM: This output, Alarm A, is enabled through OUTSEL bit of RTC_CTRL register.
- (2) Alternate function input:
- RTC_TS: Timestamp event
 - RTC_TAMP1: Tamper event detection 1
 - RTC_TAMP2: Tamper event detection 2
 - RTC_TAMP3: Invasion event detection 3
 - RTC_REFIN: 50 or 60 reference clock inputs

21.5 Functional Description

21.5.1 I/O Pin Controlled by RTC

RTC_OUT, RTC_TS and RTC_TAMP1 in RTC can be mapped to the same pin (PC13).

The output selection of RTC_ALARM is configured through RTC_TACFG, and PC13VAL bit of RTC_TACFG register is used to select RTC_ALARM to configure push-pull output or open-drain output.

When PC13 pin does not use RTC alternate function, PC13 pin is forced to be push-pull output by setting PC13EN bit of RTC_TACFG register; PC13VAL bit is used to set the value of PC13 pin output data. Then the push-pull output and data value of PC13 pin can be maintained in standby mode.

The following table shows the priority sequence followed by the output mechanism:

Table 62 PC13 Pin Controlled by RTC

Pin configuration and function	RTC_ALARM output enable	RTC_CALIB output enable	RTC_TAMP1 input enable	RTC_TS input enable	PC13EN	PC13VAL
RTC_ALARM Open-drain output	1	No effect	No effect	No effect	No effect	0
RTC_ALARM Push-pull output	1	No effect	No effect	No effect	No effect	1
RTC_CALIB Push-pull output	0	1	No effect	No effect	No effect	No effect
RTC_TAMP1 Floating input	0	0	1	0	No effect	No effect
RTC_TS and RTC_TAMP1 Floating input	0	0	0	1	No effect	No effect
RTC_TS Floating input	0	0	0	1	No effect	No effect
Forced to push-pull output	0	0	0	0	1	PC13 output data value
Wake-up pin or standard GPIO	0	0	0	0	0	No effect

When PC14 and PC15 do not use LSECLK oscillator, PC14/PC15 can be forced to be push-pull output by setting PC14EN and PC15EN bits of RTC_TACFG register; PC14VAL and PC15VAL bits set the output data, and the push-pull output and data value of PC14 and PC15 can be maintained in standby mode.

The following table shows the priority sequence followed by the output mechanism:

Table 63 PC14 Pin Controlled by LSECLK

Pin configuration and function	LSEEN bit of RCM_BDCTRL register	LSEBCFG bit of RCM_BDCTRL register	PC14EN	PC14VAL
LSECLK oscillator	1	0	No effect	No effect
LSECLK bypass	1	1	No effect	No effect
Forced to push-pull output	0	No effect	1	PC14 output data value
Standard GPIO	0	No effect	0	No effect

Table 64 PC15 Pin Controlled by LSECLK

Pin configuration and function	LSEEN bit of RCM_BDCTRL register	LSEBCFG bit of RCM_BDCTRL register	PC15EN	PC15VAL
LSECLK oscillator	1	0	No effect	No effect
Forced to push-pull output	1	1	1	PC15 output data value
	0	No effect		
Standard GPIO	0	No effect	0	No effect

21.5.2 Timebase Unit

Clock source

RTC has three clock sources:

- External LSECLK crystal oscillator
- External HSECLK crystal oscillator
- Internal LSICLK

Different clock sources are configured through RCM peripheral of clock controller.

Prescaler

When backup power supply is used, the power consumption of RTC peripherals should be as low as possible. Considering power consumption, RTC internally adopts dual prescaler, 7-bit asynchronous prescaler APSC and 15-bit synchronous prescaler SPSC.

RTCCLK first passes through the asynchronous prescaler, and the clock after frequency division reaches the synchronous prescaler. Two prescalers can be reasonably configured to generate a 1Hz clock for calendar.

When the prescaler is used, it is suggested that the asynchronous prescaler should be adjusted as high as possible to reduce power consumption.

The synchronous prescaled value can also be used as the reload value of the subsecond counter.

21.5.3 Clock Calibration

Clock synchronization

RTC can realize clock synchronization according to external high-precision 244chmi and the register RTC_SHIFT. The deviation between RTC clock and external clock is detected mainly by acquiring the timestamps of subsecond time period twice. Since the synchronous prescaled value is used as the reload value of the subsecond counter, and the SFSEC bit of register RTC_SHIFT is used in the subsecond counter, the SFSEC bit can be adjusted to finely tune the RTC clock and increase or decrease several cycles artificially.

Reference clock

RTC has internal reference clock detection, which can be used to compensate the deviation of external LSECLK crystal oscillator. Set RCLKDEN bit to enable the reference clock detection, compare the external 50Hz or 60Hz reference clock with the internal 1Hz clock of RTC through RTC_REFIN pin, and through this mechanism, the 1Hz clock after LSECLK frequency division is automatically compensated.

After the reference clock detection is enabled, the synchronous and asynchronous prescaler of the clock unit must be configured as the default value.

The reference clock detection cannot be used simultaneously with the clock synchronization, and it should be disabled in standby mode.

RTC digital calibration

RTC uses 2^{20} RTCCLKs as a calibration cycle by default. In addition, 2^{19} and 2^{18} RTC_CLK can be set as a calibration cycle through the registers CALW16 and

CALW8. When LSECLK is used as RTCCLK clock source, the calibration cycle of RTC is 32s, 16s, 8s.

- 16s calibration cycle; the hardware sets RECALF[0] to “0”
- 8s calibration cycle; the hardware sets RECALF[1:0] to “00”

Take 32s calibration cycle as an example, the calibration mechanism is to add or reduce some RTCCLK signals in the calibration cycle.

- When RECALF is used, RECALF RTCCLKs are reduced every 2^{20} RTCCLK
- When ICALFEN is used and ICALFEN=1, one RTCCLK is added every 2^{11} RTCCLK
- When RECALF is used and ICALFEN, $(512 * ICALFEN - RECALF)$ RTCCLKs are added every 2^{20} RTCCLK

21.5.4 RTC Write Protection

In order to prevent counting exception caused by accidental write, RTC register adopts write protection mechanism. Only when the write protection is removed, can the register with write protection function be operated.

After power-on, RTC register will enter the write protection state and the protection cannot be removed by system reset. The write protection can be removed by writing special keywords ‘0xCA’ and ‘0x53’ to the register RTC_WRPROT. If the wrong keyword is written, RTC will immediately enable write protection.

21.5.5 Calendar Register

RTC has subsecond, time and date shadow registers encoded by BCD, which are RTC_SUBSEC, RTC_TIME and RTC_DATE respectively. The current calendar can be obtained by accessing the shadow register or obtained directly from the calendar counter. The time system of 24 hours and 12 hours can be selected by TIMEFCFG bit of configuration register RTC_CTRL.

RTC updates the shadow register every two RTCCLK cycles, and sets the flag bit RSFLG. When waking up from shutdown or standby mode, generally the shadow register will not be updated, which requires waiting for up to two RTCCLK cycles. The reset of shadow register is caused by system reset.

The shadow register is synchronized with f_{APB1} .

The way to read the calendar can be selected by RCMCFG bit of configuration register RTC_CTRL.

RCMCFG=0, read the calendar from the shadow register

In this mode, it is recommended that f_{APB1} is greater than $7 * f_{RTCCLK}$. If f_{APB1} is too small, to ensure the normal reading of calendar value, it is required to read the shadow register twice. If the calendar obtained twice is the same, the calendar is read successfully.

After the shadow register is updated, the flag bit RSFLG will be set. The software can read the calendar only after the bit RSFLG is set. Every time the calendar is read, the RSFLG flag should be cleared manually.

When waking up from stop or standby mode, since the shadow register is not updated, the RSFLG flag should be cleared immediately.

RCMCFG=1, read the calendar from the calendar counter

When f_{APB1} is less than $7 * f_{RTCCLK}$ or the system is woken from low-power mode, it is recommended to read the calendar directly from the calendar counter.

If RSFLG bit is not set to 1 when reading the calendar just at the stage of calendar counter change, it is required to read the calendar twice. Therefore, it is

also recommended to read the calendar counter twice. When the read calendar value is the same twice, it means that the calendar is read successfully.

21.5.6 Time Compensation

Due to seasonal changes, time compensation is sometimes needed to make it more suitable for daily needs. RTC is integrated with time compensation unit and its summer time flag. Users can choose whether to turn on time compensation according to their own needs.

By setting STCCFG bit of the register RTC_CTRL, the summer time will increase by 1 hour; by setting WTCCFG bit of the register RTC_CTRL, the winter time will decrease by 1. BAKP flag is used to record whether the summer time is set.

21.5.7 Programmable Alarm

As a real-time clock, RTC integrates alarm function, and it runs mainly through alarm cock configuration register and alarm mask, in combination with calendar counter.

Configure the alarm and alarm mask through the register RTC_ALRMA、RTC_ALRMASK, and the alarm mask informs RTC to pay attention to the time period of the alarm. After the alarm function is enabled, the alarm will be triggered only when the concerned time period reaches the set value. At this time, the alarm flag is set. If the alarm interrupt is enabled, the interrupt processing will be triggered.

Select “seconds” as the time period of the alarm, and only when the synchronous prescaler value is greater than 2, can the alarm operate normally.

21.5.8 Timestamp

RTC supports timestamp function and the RTC_TS pin works together with the timestamp register.

The timestamp polarity is detected through TSETCFG bit of the register RTC_CTRL. When RTC_TS pin recognizes the external timestamp edge signal, RTC will automatically latch the current calendar in the subsecond, time and date timestamp registers, and the timestamp flag bit TSFLG will be set to 1. If the timestamp interrupt is enabled, the timestamp interrupt processing will be triggered.

When TSFLG flag bit is set to 1, and a timestamp event occurs, the timestamp will overrun, and the flag bit TSOVRFLG will be set to 1. If a timestamp event is detected once TSFLG flag is cleared, both TSFLG and TSOVRFLG flags will be set to 1.

21.5.9 Backup Domain

After the main power supply V_{DD} is powered off, the backup domain register will be powered by VBAT automatically. System resetting, NRST pin resetting, and resetting after the low mode is waken up will not affect the backup domain register. When VBAT is powered off or tamper event occurs, the backup domain register will be reset.

The backup domain register can be used to cache user data, and can be used as a state flag to realize some function application by using the characteristics that the system reset data will remain unchanged.

21.5.10 Tamper Detection

Tamper detection is a kind of data self-destruction protection device to prevent data leakage caused by tamper. Through the hardware circuit design, the tamper detection signal is transmitted to the tamper detection pin.

Tamper detection has multiple tamper detection pins, and each pin is enabled by a register bit separately. In order to detect real tamper events better, signal

filtering can be configured, and tamper detection polarity can be configured for each pin.

Tamper detection polarity

The low level/rising edge and high level/falling edge can be selected as tamper detection polarity through TPxAL bit in the register RTC_TACFG.

Tamper signal filter

TPSFSEL bit of the register RTC_TACFG is used to configure the sampling frequency of tamper detection, and TPFSEL bit of RTC_TACFG is used to configure after how many valid tamper signals are detected continuously, a tamper event can be generated.

In particular, if a tamper signal has been generated on the tamper detection pin before the tamper detection pin is enabled, a tamper event will be immediately generated on the enabled tamper detection pin.

Tamper timestamp

At some times, in order to record the tamper detection events, RTC can latch the current tamper timestamp and this function can be enabled quickly through TPTSEN bit of the register RTC_TACFG, not needing to enable the timestamp function additionally.

21.5.11 Automatic Wake-up

Compared with RTC alarm, the hardware structure of the automatic wake-up is simpler, and it has no complicated configuration process of RTC alarm, so it is a good scheme to wake up the low power consumption.

There is a 16-bit self-decrement reload counter in RTC, and it is used to wake up the device automatically.

The clock of this counter is selected by WUCLKSEL bit of the register RTC_CTRL, and by selecting different clocks, the automatic wake-up cycle can be configured from 122 μ s to 36h. First turn off the automatic wake-up, namely, clear WUTEN; when WUTWFLG flag bit is set to 1, configure WUCLKSEL bit of the RTC_CTRL register and the reload register RTC_AUTORLD.

When the counter decreases to 0, a wake-up event will be generated, WUTFLG flag bit will be set to 1, and before entering the next round of automatic wake-up, this flag bit must be cleared.

21.5.12 RTC Output

RTC output transmits the internal RTC calibration clock, alarm signal, and automatic wake-up signal to the outside through PC13 pin.

RTC calibration clock

Calibration clock output is generally used to observe the accuracy of RTC clock source, and the observed value is used to calibrate the clock source. 512Hz and 1Hz signal output sources can be selected through CALOSEL bit of RTC_CTRL register, and CALOEN bit of RTC_CTRL register can enable the calibration output.

Alarm and automatic wake-up signal

When the alarm or automatic wake-up is running, these two events can be output as pulse signals. OUTSEL bit of RTC_CTRL register is used to select the

signal output source, and POLCFG bit is used to configure the output polarity.

21.6 Register Address Mapping

Table 65 RTC Register Address Mapping

Register name	Description	Offset address
RTC_TIME	RTC time register	0x00
RTC_DATE	RTC date register	0x04
RTC_CTRL	RTC control register	0x08
RTC_STS	RTC state register	0x0C
RTC_PSC	RTC prescaler register	0x10
RTC_AUTORLD	RTC auto reload register	0x14
RTC_ALRMA	RTC alarm A register	0x1C
RTC_WRPROT	RTC write protection register	0x24
RTC_SUBSEC	RTC subsecond register	0x28
RTC_SHIFT	RTC shift register	0x2C
RTC_TSTIME	RTC timestamp time register	0x30
RTC_TSDATE	RTC timestamp date register	0x34
RTC_TSSUBSEC	RTC timestamp subsecond register	0x38
RTC_CAL	RTC calibration register	0x3C
RTC_TACFG	RTC tamper and multiplexing configuration register	0x40
RTC_ALRMAS	RTC alarm A subsecond register	0x44
RTC_BAKPx	RTC backup register	0x50-0x60

21.7 Register Functional Description

21.7.1 RTC time register (RTC_TIME)

RTC_TIME is calendar time shadow register, and this register can be written only in initialization mode and is in write protection state.

Offset address: 0x00

Power-on reset value: 0x0000 0000

System reset: 0xXXXX XXXX

Field	Name	R/W	Description
3:0	SECU	R/W	Second Ones Unit in BCD Format Setup
6:4	SECT	R/W	Second Ten's Place Unit in BCD Format Setup
7	Reserved		
11:8	MINU	R/W	Minute Ones Unit in BCD Format Setup

Field	Name	R/W	Description
14:12	MINT	R/W	Minute Ten's Place Unit in BCD Format Setup
15	Reserved		
19:16	HRU	R/W	Hour Ones Unit in BCD Format Setup
21:20	HRT	R/W	Hour Ten's Place Unit in BCD Format Setup
22	TIMEFCFG	R/W	Time Format Configure 0: AM or 24-hour system 1: PM
31:23	Reserved		

21.7.2 RTC date register (RTC_DATE)

RTC_DATE is calendar date shadow register, and this register can be written only in initialization mode and is in write protection state.

Offset address: 0x04

Reset value: 0x0000 2101

Field	Name	R/W	Description
3:0	DAYU	R/W	Day Ones Unit in BCD Format Setup
5:4	DAYT	R/W	Day Ten's Place Unit in BCD Format Setup
7:6	Reserved		
11:8	MONU	R/W	Month Ones Unit in BCD Format Setup
12	MONT	R/W	Month Ten's Place Unit in BCD Format Setup
15:13	WEEKSEL	R/W	Week Day Units Select 000: Disable 001: Monday ... 111: Sunday
19:16	YRU	R/W	Year Ones Unit in BCD Format Setup
23:20	YRT	R/W	Year Ten's Place Unit in BCD Format Setup
31:24	Reserved		

21.7.3 RTC control register (RTC_CTRL)

- (1) The bits 7, 6 and 4 of this register can be written only in initialization mode.
- (2) It is not recommended to rewrite this register when the number of hours in the calendar increases, which is because the correct increment of hours may be masked.
- (3) The written values of STCCFG and WTCCFG will take effect from next second.
- (4) This register is under write protection.

Offset address: 0x08

Power-on reset value: 0x0000 0000

System reset: 0xXXXX XXXX

Field	Name	R/W	Description
-------	------	-----	-------------

Field	Name	R/W	Description
2:0	WUCLKSEL	R/W	Wakeup Clock Select 000: RTC/16 001: RTC/8 010: RTC/4 011: RTC/2 10x: clk_spre (usually 1Hz) 11x: clk_spre (usually 1Hz) and add 216 to WUAUTORE counter value
3	TSETECFG	R/W	Time Stamp Event Trigger Edge Configure This bit indicates that RTC_TS generates a timestamp event on rising edge or falling edge. 0: Rising edge 1: Falling edge This bit will be changed when TSEN=0.
4	RCLKDEN	R/W	RTC_REFIN reference clock detection enable 0: Disable 1: Enable SPSC must be 0x00FF
5	RCMCFG	R/W	Read Calendar Value Mode Configure 0: The calendar value is read from the shadow register, and the shadow register is updated every two RTCCLK cycles 1: The calendar value is read from the calendar counter If the clock frequency of APB1 is lower than seven times of RTCCLK frequency, RCMCFG must be set to 1.
6	TIMEFCFG	R/W	Time Format Configure 0: 24-hour/day format 1: AM/PM time format
7	Reserved		
8	ALREN	R/W	Alarm A Function Enable 0: Disable 1: Enable
9	Reserved		
10	WUTEN	R/W	Wakeup Timer Enable 0: Disable 1: Enable
11	TSEN	R/W	Time Stamp Enable 0: Disable 1: Enable
12	ALRIEN	R/W	Alarm A Interrupt Enable 0: Disable 1: Enable
13	Reserved		
14	WUTIEN	R/W	Wakeup Timer Interrupt Enable 0: Disable 1: Enable
15	TSIEN	R/W	Time Stamp Interrupt Enable 0: Disable 1: Enable
16	STCCFG	R/W	Summer Time Change Configure The bit will always be 0 in the reading process; if this bit is set not in the

Field	Name	R/W	Description
			initialization mode, the calendar time will increase by 1. 0: Invalid 1: The current time increases by 1 hour to calibrate the summer time variation
17	WTCCFG	R/W	Winter Time Change Configure The bit will always be 0 in the reading process; if this bit is set not in the initialization mode, and HRx of RCT_TIME register is 0, this bit is invalid, and if HRx is not 0, the calendar time will decrease by 1. 0: Invalid 1: The current time increases by 1 hour to calibrate the winter time variation
18	BAKP	R/W	Backup Value Setup This bit indicates whether the summer time has changed and is written by the user.
19	CALOSEL	R/W	Calibration Output Value Select When CALOEN=1, this bit is used to select the output signal of RTC_CALIB. 0: 512Hz 1: 1Hz The above frequency is valid when RTCCLK is 32.768kHz and the prescaler is at the default value (APSC=127, SPSC=255).
20	POLCFG	R/W	Output Polarity Configure This bit indicates the level state of the pin when ALRAF/WUTFLG bit is set to 1 (depending on OUTSEL bit). 0: High level 1: Low level
22:21	OUTSEL	R/W	Output Way Select This bit is used to select the flag bit associated with RTC_ALARM output 00: Output is 251chmitt251 01: Alarm A output is enabled 10: Reserved 11: Wake-up output is enabled
23	CALOEN	R/W	Calibration Output Enable This bit is used to enable RTC_CAL output 0: Disable 1: Enable
31:24	Reserved		

21.7.4 RTC state register (RTC_STS)

This register (except RTC_STS[13:8] bit) is in write protection state.

Offset address: 0x0C

Power-on reset value: 0x0000 0007

System reset: 0xXXXX XXXX

Field	Name	R/W	Description
0	ALRWFLG	R	Alarm A Write Occur Flag When ALREN=0 for RTC_CTRL, the value of alarm A will change and this bit will be set to 1 by hardware; this bit will be cleared by hardware in initialization mode. 0: The alarm A can be updated 1: The alarm A cannot be updated

Field	Name	R/W	Description
1	Reserved		
2	WUTWFLG	R	Wakeup Timer Write Occur Flag When WUTEN=0, this bit is set to 1 by hardware after two RTCCLK cycles are set; after WUTEN=1, this bit is cleared after two RTCCLK cycles; When WUTEN=0 and WUTWFLG=1, the value of wake-up timer can be changed. 0: It is not allowed to update the wake-up timer configuration 1: It is allowed to update the wake-up timer configuration
3	SOPFLG	R	Shift Operation Pending Occur Flag 0: Not occur 1: Occurred When a shift operation is generated by writing to RTC_SHIFT register, this bit will be set to 1 by hardware immediately. After corresponding shift operation is performed, this bit will be cleared by software. It is invalid to write to SOPFLG.
4	INITSFLG	R	Initialization State Occur Flag When the "year" field in the calendar is not "0", this bit will be set by hardware. 0: Not occur 1: Occurred
5	RSFLG	RC_W0	Registers Synchronization Occur Flag When the content in the calendar register is copied to the shadow registers (RTC_SUBSEC, RTC_TIME and RTC_DATE), this bit is set to 1 by hardware; when shifting operation is pending (SOPFLG=1) or is in the mode that the shadow register is ignored (RCMCFG=1), this bit is cleared by hardware in initialized mode; or this bit can be cleared by software. This bit is cleared by hardware/software in initialization mode. 0: Not synchronized 1: Synchronized
6	RINITFLG	R	Register Initialization Occur Flag This bit is set to "1", RTC is in initialization state, and the time, date and prescaler registers can be updated. 0: Cannot be initialized 1: Initialized
7	INITEN	R/W	Initialization Mode Enable 0: Free run mode 1: Initialization mode; it is used to program RTC_TIME, RTC_DATE and RTC_PSC. The counter stops counting, and after INITEN is reset, the counter will start counting from a new value.
8	ALRAFLG	RC_W0	Alarm A Match Occur Flag When RTC_TIME and RTC_DATE match the alarm A register RTC_ALRMA, this flag is set by hardware. This flag can be cleared by writing 0 by software.
9	Reserved		
10	WUTFLG	RC_W0	Wakeup Timer Occur Flag When the auto refresh counter counts to 0, this bit will be set to 1 by hardware; it is cleared by writing 0 by software. Clear this flag 1.5 RTCCLK cycles before WUTFLG is set to 1 again.
11	TSFLG	RC_W0	Time Stamp Occur Flag When a timestamp event occurs, this flag is set to 1 by hardware; it is cleared by writing 0 by software.
12	TSOVRFLG	RC_W0	Time Stamp Overflow Occur Flag When TSFLG=1 and a timestamp event is generated, this flag bit is set to 1 by hardware; it is cleared by writing 0 by software. It is recommended to clear this bit after TSFLG flag bit is cleared.
13	TP1FLG	RC_W0	RTC_TP1FLG Detection Occur Flag When a tamper event is detected in RTC_TP1FLG input, this flag is set to 1 by hardware, it can be cleared by writing 0 by software.

Field	Name	R/W	Description
14	TP2FLG	RC_W0	RTC_TP2FLG Detection Occur Flag When a tamper event is detected in RTC_TP2FLG input, this flag is set to 1 by hardware, it can be cleared by writing 0 by software.
15	TP3FLG	RC_W0	RTC_TP3FLG Detection Occur Flag When tamper event is detected in RTC_TP3FLG input, this flag is set to 1 by hardware, and cleared by software.
16	RCALPFLG	R	Recalibration Pending Occur Flag When the software writes to RTC_CAL, this bit is set to 1 automatically, and the RTC_CAL register is locked. This bit will return 0 when other new calibration setting is performed.
31:17	Reserved		

21.7.5 RTC prescaler reegister (RTC_PSC)

The register can only be written in the initialization mode, and the initialization must be completed by two independent write accesses, which is in write protected state.

Offset address: 0x10

Power-on reset value: 0x007F 00FF

System reset: 0xXXXX XXXX

Field	Name	R/W	Description
14:0	SPSC	R/W	Synchronous Prescaler Coefficient $ck_spre\ frequency = ck_apre\ frequency / (SPSC + 1)$
15	Reserved		
22:16	APSC	R/W	Asynchronous prescaler factor (Asynchronous Prescaler Coefficient) $ck_apre\ frequency = RTCCLK\ frequency / (APSC + 1)$
31:23	Reserved		

21.7.6 RTC auto reload register (RTC_AUTORLD)

This register can be written only when WUTEFLG of RTC_STS is set to 1, and it is in write protection state.

Offset address: 0x14

Power-on reset value: 0x0000 FFFF

System reset: 0xXXXX XXXX

Field	Name	R/W	Description
15:0	WUAUTORE	R/W	Wakeup Auto-reload Value Setup When the wake-up counter is waken up (WUTEN=1), this flag bit will be set to 1 in each CLK_WUAUTORE cycle, and CLK_WUAUTORE cycle can be set by WUCLKSEL bit of RTC_CTRL register. When WUCLKSEL[2]=1, the wake-up counter will be set to 17 bits, WUCLKSEL[1] is WUAUTORE[16], and is the most critical bit reloaded to the timer. After WUTEN is set, CLK_WUAUTORE cycle will appear to the first assertion of WUTFLG Disable WUCLKSEL[2:0]=011(RTCCLK/2) from WUAUTORE[15:0] to 0x0000.
31:16	Reserved		

21.7.7 RTC alarm A register (RTC_ALRMA)

This register can be written only when ALRWFLG of RTC_STS is set to 1 or in initialization mode, and it is in write protection state.

Offset address: 0x1C

Power-on reset value: 0x0000 0000

System reset: 0xXXXX XXXX

Field	Name	R/W	Description
3:0	SECU	R/W	Second Ones Unit in BCD Format Setup
6:4	SECT	R/W	Second Ten's Place Unit in BCD Format Setup
7	SECMEN	R/W	Alarm A Seconds Mask Enable 0: If the "second" matches, set Alarm A 1: Mask the effect of the "second" value on Alarm A
11:8	MINU	R/W	Minute Ones Unit in BCD Format Setup
14:12	MINT	R/W	Minute Ten's Place Unit in BCD Format Setup
15	MINMEN	R/W	Alarm A Minutes Mask Enable 0: If the "minute" matches, set Alarm A 1: Mask the effect of the "minute" value on Alarm A
19:16	HRU	R/W	Hour Ones Unit in BCD Format Setup
21:20	HRT	R/W	Hour Ten's Place Unit in BCD Format Setup
22	TIMEFCFG	R/W	Time Format Configure 0: AM or 24-hour system 1: PM
23	HRMEN	R/W	Alarm A Hours Mask Enable 0: If the "hour" matches, set Alarm A 1: Mask the effect of the "hour" value on Alarm A
27:24	DAYU	R/W	Day Ones Unit in BCD Format Setup
29:28	DAYT	R/W	Day Ten's Place Unit in BCD Format Setup
30	WEEKSEL	R/W	Week Day Select 0: DAYU means date 1: DAYU means the number of weeks. DAYT has no effect.
31	DATEMEN	R/W	Alarm A Date Mask Enable 0: If the date/week matches, set Alarm A 1: Mask the effect of the date/week value on Alarm A

21.7.8 RTC write protection register (RTC_WRPROT)

Offset address: 0x24

Reset value: 0x0000 0000

Field	Name	R/W	Description
15:0	KEY	W	Write Protection Key Value Setup This byte is written by software; read this byte and it is always 0x00.
31:16	Reserved		

21.7.9 RTC subsecond register (RTC_SUBSEC)

Offset address: 0x28

Power-on reset value: 0x0000 0000

System reset value: 0xXXXX XXXX

Field	Name	R/W	Description
15:0	SUBSEC	R	Sub Second Value Setup SUBSEC is the value of synchronous prescaler counter. It is determined by the following formula: Subsecond value=(SPSC-SUBSEC)/(SPSC+1) After one shift operation is performed, SUBSEC may be greater than SPSC. The correct time/date is one second less than RTC_TIME/RTC_DATE.
31:16	Reserved		

21.7.10 RTC shift register (RTC_SHIFT)

This register is in write protection state.

Offset address: 0x2C

Power-on reset value: 0x0000 0000

System reset value: 0xXXXX XXXX

Field	Name	R/W	Description
14:0	SFSEC	W	Subtract a Fraction of a Second Setup This bit field can only be written; read this byte and it is always 0. Writing to this bit is invalid while an operation is being executed. The set SFSEC value will be added to the synchronous prescaler counter. If the counter counts down, the clock will be delayed, and the delay time is determined by the following formula: Delay (seconds)=SFSEC/(SPSC+1) When it takes effect at the same time with ADD1SECEN, the advance clock will be added by a fraction of a second; the specific added value is determined by the following formula: Advance(seconds)=(1-(SFSEC/(SPSC+1))) Conduct write operation to this bit and RSFLG bit can be cleared. The software keeps running until RSFLG is set to 1 to ensure that the value of the shadow register is synchronized with the shift time.
30:15	Reserved		
31	ADD1SECEN	W	Add One Second Enable 0: Not added 1: The clock/calender increases by one second This bit can only be written; read this byte and it is always 0. Writing to this bit is invalid while an operation is being executed. When it takes effect at the same time with SFSEC, it can increase the value of the clock by several tenths of a second.

21.7.11 RTC timestamp time register (RTC_TSTIME)

This register is valid only when TSFLG of RTC_STS is set to 1. When TSFLG bit is reset, the content of this register will be cleared.

Offset address: 0x30

Power-on reset value: 0x0000 0000

System reset value: 0xXXXX XXXX

Field	Name	R/W	Description
3:0	SECU	R	Second Ones Unit in BCD Format Setup
6:4	SECT	R	Second Ten's Place Unit in BCD Format Setup
7	Reserved		
11:8	MINU	R	Minute Ones Unit in BCD Format Setup

Field	Name	R/W	Description
14:12	MINT	R	Minute Ten's Place Unit in BCD Format Setup
15	Reserved		
19:16	HRU	R	Hour Ones Unit in BCD Format Setup
21:20	HRT	R	Hour Ten's Place Unit in BCD Format Setup
22	TIMEFCFG	R	Time Format Configure 0: AM or 24-hour system 1: PM
31:23	Reserved		

21.7.12 RTC timestamp date register (RTC_TSDATE)

This register is valid only when TSFLG bit of RTC_STS is set to 1. When TSFLG bit is reset, this register will be cleared.

Offset address: 0x34

Power-on reset value: 0x0000 0000

System reset value: 0xXXXX XXXX

Field	Name	R/W	Description
3:0	DAYU	R	Day Ones Unit in BCD Format Setup
5:4	DAYT	R	Day Ten's Place Unit in BCD Format Setup
7:6	Reserved		
11:8	MONU	R	Month Ones Unit in BCD Format Setup
12	MONTH	R	Month Ten's Place Unit in BCD Format Setup
15:13	WEEKSEL	R	Week Day Units Select 000: Disable 001: Monday ... 111: Sunday
31:16	Reserved		

21.7.13 RTC timestamp subsecond register (RTC_TSSUBSEC)

This register is valid only when TSFLG bit of RTC_STS register is set to 1. When TSFLG bit is reset, the content of this register will be cleared.

Offset address: 0x38

Power-on reset value: 0x0000 0000

System reset value: 0xXXXX XXXX

Field	Name	R/W	Description
15:0	SUBSEC	R	Sub Second Value Setup When a timestamp event occurs, SUBSEC[15:0] is the value in synchronous prescaler counter.
31:16	Reserved		

21.7.14 RTC calibration register (RTC_CAL)

This register is in write protection state.

Offset address: 0x3C

Power-on reset value: 0x0000 0000

System reset value: 0xXXXX XXXX

Field	Name	R/W	Description
8:0	RECALF	R/W	Reduced Calibration Frequency Reduced calendar frequency: Shield RECALF pulses within 2 ²⁰ RTCCLK pulses (32sec if the output frequency is 32768 Hz) and the calendar frequency will be reduced (the resolution is 0.9537 ppm). Increased calendar frequency: It takes effect at the same time with ICALFEN
12:9	Reserved		
13	CAL16CFG	R/W	16 Second Calibration Cycle Period Configure When CAL16CFG is set to 1, 16-second calibration cycle is used, and it cannot be set to 1 at the same time with CAL8CFG bit. When CAL16CFG=1, RECALF[0] is always 0.
14	CAL8CFG	R/W	8 Second Calibration Cycle Period Configure When CAL8CFG is set to 1, 8-second calibration cycle is used, and it cannot be set to 1 at the same time with CAL16CFG bit. When CAL8CFG=1, RECALF[1:0] is always 00.
15	ICALFEN	R/W	Increase Calibration Frequency Enable 0: RTCCLK pulse is not increased 1: One RTCCLK pulse is increased (the frequency increases by 488.5 ppm) every 211 pulses It takes effect at the same time with RECALF, and when the resolution is high, the calendar frequency will be reduced. If the input frequency is 32768Hz, the number of RTCCLK pulses added in the 32-second window is determined by the following formula: (512*ICALFEN)-RECALF.
31:16	Reserved		

21.7.15 RTC tamper and multiplexing configuration register (RTC_TACFG)

Offset address: 0x40

Power-on reset value: 0x0000 0000

System reset value: 0xXXXX XXXX

Field	Name	R/W	Description
0	TP1EN	R/W	RTC_TAMP1 Input Detection Enable 0: Disable 1: Enable
1	TP1ALCFG	R/W	RTC_TAMP1 Input Active Level Configure When TPFCSSEL!=00, this bit determines that RTC_TAMP1 will trigger a tamper detection event when the input maintains high/low level. 0: Low level 1: High level When TPFCSSEL=00, this bit determines that RTC_TAMP1 triggers a tamper detection event when the input is on rising/falling edge. 0: Rising edge 1: Falling edge
2	TPIEN	R/W	amper Interrupt Enable 0: Disable 1: Enable
3	TP2EN	R/W	RTC_TAMP2 Input Detection Enable 0: Disable 1: Enable
4	TP2ALCFG	R/W	RTC_TAMP2 Input Active Level Configure When TPFCSSEL!=00, this bit determines that RTC_TAMP2 will trigger a tamper detection event when the input maintains high/low level. 0: Low level

Field	Name	R/W	Description
			1: High level When TPFSEL=00, this bit determines that RTC_TAMP2 triggers a tamper detection event on rising/falling edge 0: Rising edge 1: Falling edge
5	TP3EN	R/W	RTC_TAMP3 Input Detection Enable 0: Disable 1: Enable
6	TP3ALCFG	R/W	RTC_TAMP3 Input Active Level Configure When TPFSEL!=00, this bit determines that RTC_TAMP3 will trigger a tamper detection event when the input maintains high/low level. 0: Low level 1: High level When TPFSEL=00, this bit determines that RTC_TAMP3 triggers a tamper detection event on rising/falling edge 0: Rising edge 1: Falling edge
7	TPTSEN	R/W	Tamper Detection Event Timestamp Enable This bit determines whether the timestamp generated by the tamper detection event is saved 0: Not saved 1: Saved This bit is still valid when TSEN=0 for RTC_CTRL register.
10:8	TPSFSEL	R/W	Tamper Sampling Frequency Select These bits determine the sampling frequency of each input of RTC_TAMPx. 0x0: RTCCLK/32768 0x1: RTCCLK/16384 0x2: RTCCLK/8192 0x3: RTCCLK/4096 0x4: RTCCLK/2048 0x5: RTCCLK/1024 0x6: RTCCLK/512 0x7: RTCCLK/256
12:11	TPFCSEL	R/W	RTC_TAMPx Filter Count Select These bits 258chmitt258258 the number of sampling times after which the tamper event is activated on specific level (TAMP*TRG). TPFCSEL is valid for each input of RTC_TAMPx. 0x0: Activate the tamper event on the edge where RTC_TAMPx input is converted into valid level 0x1: Continuous sampling twice 0x2: Continuous sampling four 0x3: Continuous sampling eight
14:13	TPPRDUSEL	R/W	RTC_TAMPx Precharge Duration Select These bits determine the number of RTCCLK cycles which are enabled by pull-up resistor before sampling; which is valid in each input of RTC_TAMPx. 0x0: 1 0x1: 2 0x2: 4 0x3: 8
15	TPPUDIS	R/W	RTC_TAMPx Pull-up Function Disable This bit determines whether all RTC_TAMPx pins are precharged before

Field	Name	R/W	Description
			sampling. 0: Enable (internal pull-up is enabled) 1: Disable
17:16	Reserved		
18	PC13VAL	R/W	RTC_ALARM Output Type/PC13 Value Configure When PC13 is used to output RTC_ALARM, this bit determines the output mode of RTC_ALARM: 0: Open-drain output 1: Push-pull output When all RTC multiplexing functions are disabled and PC13EN=1, this bit is used to set PC13 output value.
19	PC13EN	R/W	PC13 Mode Enable 0: PC13 is controlled by GPIO configuration register, and in standby mode, PC13 is floating. 1: When RTC multiplexing function is disabled, PC13 is forced to push-pull output mode.
20	PC14VAL	R/W	PC14 Output Value Setup Disable LSECLK and PC14EN=1, and this bit sets the output value of PC14.
21	PC14EN	R/W	PC14 Mode Enable 0: PC14 is controlled by GPIO configuration register, and in standby mode, PC14 is floating. 1: When LSECLK is disabled, PC14 is forced to push-pull output mode
22	PC15VAL	R/W	PC15 Output Value Setup Disable LSECLK and PC15EN=1, and this bit sets the output value of PC15.
23	PC15EN	R/W	PC15 Mode Enable 0: PC15 is controlled by GPIO configuration register, and in standby mode, PC15 is floating. 1: When LSECLK is disabled, PC15 is forced to push-pull output mode.
31:24	Reserved		

21.7.16 RTC alarm A subsecond register (RTC_ALRMASS)

This register can be written only when ALREN of RTC_CTRL register is reset or is in initialization mode.

This register is in write protection state.

Offset address: 0x44

Power-on reset value: 0x0000 0000

System reset value: 0xXXXX XXXX

Field	Name	R/W	Description
14:0	SUBSEC	R/W	Sub Second Value Setup The subsecond value is compared with the value in the synchronous prescaler counter to determine whether to activate the alarm A, and only the bits from 0 to MASKSEL-1 are compared.
23:15	Reserved		
27:24	MASKSEL	R/W	Mask the Most-significant Bits Starting at This Bit Select 0: Alarm A is not compared. The alarm is set when the second unit increases by 1 1: When comparing with alarm A, SUBSEC[14:1] is not involved, and only

Field	Name	R/W	Description
			<p>SUBSEC[0] is involved</p> <p>2: When comparing with alarm A, SUBSEC[14:2] is not involved, and only SUBSEC[1:0] is involved</p> <p>3: When comparing with alarm A, SUBSEC[14:3] is not involved, and only SUBSEC[2:0] is involved</p> <p>...</p> <p>12: When comparing with alarm A, SUBSEC[14:12] is not involved, and only SUBSEC[11:0] is involved</p> <p>13: When comparing with alarm A, SUBSEC[14:13] is not involved, and only SUBSEC[12:0] is involved</p> <p>14: When comparing with alarm A, SUBSEC[14] is not involved, and only SUBSEC[13:0] is involved</p> <p>15: When comparing the alarm A, 15 SUBSEC bits all take part in, and the alarm can be activated only when all of them match.</p> <p>The synchronous counter overrun bit (Bit 15) is never compared. This bit is not 0 only after shift operation.</p>
31:28			Reserved

21.7.17 RTC backup register (RTC_BAKPx) (x=0-4)

Offset address: 0x50-0x60

Power-on reset value: 0x0000 0000

Reset value: 0xXXXX XXXX

Field	Name	R/W	Description
31:0	BAKP	R/W	<p>Backup Value Setup</p> <p>V_{BAT} will supply power after V_{DD} power supply is cut off, so this bit field is unaffected by system reset; when a tamper detection event occurs or the flash memory read protection is disabled, this register will be reset.</p> <p>The contents of this bit field are valid even if the device is running in low-power mode.</p>

22 Universal Synchronous/Asynchronous Transceiver (USART)

22.1 Full Name and Abbreviation Description of Terms

Table 66 Full Name and Abbreviation Description of Terms

Full name in English	English abbreviation
Clear to Send	CTS
Request to Send	RTS
Most Significant Bit	MSB
Least Significant Bit	LSB
Guard	GRD
Overrun	OVR

22.2 Introduction

USART (universal synchronous/asynchronous transceiver) is a serial communication device that can flexibly exchange full-duplex and half-duplex data with external devices, and meets the requirements of external devices for industry standard NRZ asynchronous serial data format. USART also provides a wide range of baud rate for selection and supports multiprocessor communication.

USART not only supports standard asynchronous transceiver mode, but also supports synchronous one-way communication and some other serial data exchange modes, such as LIN protocol, smart card protocol, IrDA SIR ENDEC specification and hardware flow control mode.

USART also supports DMA function to realize high-speed data communication.

22.3 Main Characteristics

- (1) Full duplex asynchronous communication
- (2) Single-line half-duplex communication
- (3) NRZ standard format
- (4) Characteristics of programmable serial port:
 - Data bit: 7 bits, 8 bits or 9 bits
 - Check bits: Even parity check, odd parity check, no check
 - Support 0.5, 1, 1.5 and 2 stop bits
- (5) Check control
 - Transmit the check bit
 - Check the received data
- (6) Select speed and clock tolerance with programmable 8 or 16-time oversampling rate
- (7) Programmable high or low priority
- (8) Independent transmitter and receiver enable bit

- (9) Independent signal polarity control transmitter and receiver
- (10) Switch TX/RX pin
- (11) Support timeout detection
- (12) Programmable baud rate generator, with the baud rate up to 6Mbits/s
- (13) Automatic baud rate detection
- (14) Multiprocessor communication:
 - If the address does not match, it will enter the mute mode
 - Wake up from mute mode through idle bus detection or address flag detection
- (15) Double-clock drive
 - Function of wake-up from the stop mode
 - Baud rate selection independent of PCLK
- (16) Synchronous transmission mode
- (17) Generation and detection of LIN break frame
- (18) Support the smart card interface of ISO7816-3 standard
- (19) Support IrDA protocol
- (20) Support hardware flow control and RS485 driver enable
- (21) DMA can be used for continuous communication
- (22) Support ModBus communication
 - Timeout detection
 - CR/LF character recognition
- (23) State flag bit:
 - Transmission detection flag: The transmit register is empty, the receive register is not empty, and transmission is completed
 - Error detection flag: Overrun error, noise error, parity error, frame error
- (24) Multiple interrupt sources:
 - The transmit register is empty
 - Transmission is completed
 - CTS changed
 - The receive register cannot be empty
 - Overload error
 - Bus idle
 - Parity error
 - LIN disconnection detection
 - Noise error
 - Overrun error
 - Frame error
 - Address/Character match
 - Wake up from the stop mode
 - Failed to receive interrupt on time
 - End of block interrupt

22.4 Functional Description

Table 67 USART Pin Description

Pin	Type	Description
USART_RX	Input	Data receiving
USART_TX	Output I/O (single-line mode/smart card mode)	Data transmission When the transmitter is enabled and does not transmit data, the default is high
USART_CK	Output	Clock output
USART_nRTS	Input	Request to send in hardware flow control mode
USART_nCTS	Output	Clear to send in hardware flow control mode
USART_DE	Input	Drive enable activating external transmitter/receiver

22.4.1 Single-line Half-duplex Communication

HDEN bit of USART_CTRL3 register determines whether to enter the single-line half-duplex mode.

When USART enters single-line half-duplex mode:

- The CLKEN and LINMEN bit of USART_CTRL2 register, and IREN and SCEN bits of USART_CTRL3 register must be cleared.
- RX pin is disabled.
- TX pin should be configured as open-drain output and connected with RX pin inside the chip.
- Transmitting data and receiving data can not be carried out at the same time. The data cannot be received before they are transmitted. If needing to receive data, enabling receiving can be turned on only after TXCFLG bit of USART_STS register is set to 1.
- If there is data conflict on the bus, software management is needed to allocate the communication process.

22.4.2 Frame Format

The frame format of data frame is controlled by USART_CTRL1 register

- The character length is controlled by DBLCFG bit, and can be set to 7, 8 or 9 bits
- The PCEN bit controls whether to turn on the check bit
- The PCFG bit controls the check bit is odd or even

Table 68 USART Frame Format

DBLCFG bit	PCEN bit	USART data frame
00	0	Start bit+8-bit data+stop bit
00	1	Start bit+7-bit data+odd-even parity check bit+stop bit
01	0	Start bit+9-bit data+stop bit
01	1	Start bit+8-bit data+odd-even parity check bit+stop bit

10	0	Start bit+7-bit data+stop bit
10	1	Start bit+6-bit data+parity check bit+stop bit

Configurable stop bit

Four different stop bits can be configured through STOPCFG bit of USART_CTRL2 register.

- 1 stop bit: The default stop bit
- 0.5 stop bit: Used when receiving data in smart card mode.
- 1 stop bits: Used in normal mode, single-line mode and hardware flow control mode
- 1.5 stop bits: Used when transmitting and receiving data in smart card mode

Check bit

PCFG bit of USART_CTRL1 determines the parity check bit; when PCFG=0, it is even parity check, on the contrary, it is odd parity check.

- Even check: When the number of frame data and check bit '1' is even, the even check bit is 0; otherwise it is 1.
- Odd check: When the number of frame data and check bit '1' is even, the odd check bit is 1; otherwise it is 0.
- Check generation: When transmitting data, set PCEN bit of USART_CTRL1 register, and the check bit will replace the MSB bit of the data and be transmitted.
- Parity check:
 - If the parity check fails, PEFLG flag bit of USART_STS register will be set.
 - If the check control is enabled, corresponding interrupt will be triggered. Write 1 to PECLR bit of USART_INTFCLR register, and PEFLG flag bit can be cleared.

22.4.3 Transmitter

When TXEN bit of the register USART_CTRL1 is set, the transmit shift register will output data through TX pin and the corresponding clock pulses will be output through CK pin.

22.4.3.1 Character transmit

During 264chmitt264264d264g period of USART, the least significant bit of the data will be moved out by TX pin first. In this mode, USART_TXDATA register has a buffer between the internal bus and the transmit shift register.

A data frame is composed of the start bit, character and stop bit, so there is a low-level start bit in front of each character; then there is a high-level stop bits the number of which is configurable.

Transmission configuration steps

- (1) Decide the word length by setting DBLCFG bit of USART_CTRL1 register
- (2) Decide the number of stop bits by setting STOPCFG bit of USART_CTRL2 register
- (3) If multi-buffer communication is selected, DMA should be enabled in USART_CTRL3 register
- (4) Set the baud rate of communication in USART_BR register

- (5) Set UEN bit of USART_CTRL1 register to enable USART. Wait for TXBEFLG bit of USART_STS register to be set to 1
- (6) Enable TXEN bit in USART_CTRL1 register, and transmit an idle frame
- (7) Write data to USART_TXDATA register (if DMA is not enabled, repeat step 7 for each byte to be transmitted)
- (8) Wait for TXCFLG position 1 of USART_STS register, indicating transmission completion

Note: TXEN bit cannot be reset during data transmission; otherwise, the data on TX pin will be destroyed, which is because if the baud rate generator stops counting, the data being transmitted will be lost.

22.4.3.2 Single-byte communication

TXBEFLG bit can be cleared by writing USART_TXDATA register. When the TXBEFLG bit is set by hardware, the shift register will receive the data transferred from the transmit data register, then the data will be transmitted, and the transmit data register will be cleared. The next data can be written in the data register without covering the previous data.

- (1) If TXBEIEN in USART_CTRL1 register is set to 1, an interrupt will be generated.
- (2) If USART is in the state of transmitting data, write to the data register to save the data to the TXDATA register, and transfer the data to the shift register at the end of the current data transmission.
- (3) If USART is in idle state, write to the data register, put the data into the shift register, start transmitting data, and set TXBEFLG bit to 1.
- (4) When a data transmission is completed and TXBEFLG bit is set, TXCFLG bit will be set to 1; at this time if TXCIEN bit in USART_CTRL1 register is set to 1, an interrupt will be generated.
- (5) After the last data is written in the USART_TXDATA register, before entering the low-power mode or before closing the USART module, wait to set TXCFLG to 1.

22.4.3.3 Break frame

It is regarded that the break frames all receive '0' within one frame period. One break frame can be transmitted by setting TXBFQ bit of USART_REQUEST register, and the length of the break frame is determined by DBLCFG bit of USART_CTRL1 register. If the TXBFQ bit is set, after completion of transmission of current data, the TX line will transmit a break frame, and after completion of transmission of break frame, this bit will be reset. At the end of the break frame, the transmitter inserts 1 or 2 stop bits to respond to the start bit.

Note: If the TXBFQ bit is reset before transmission of the break frame starts, the break frame will not be transmitted. To transmit two consecutive break frames, the TXBFQ bit should be set after the stop bit of the previous disconnection symbol.

22.4.3.4 Idle frame

The idle frame is regarded as a complete data frame composed entirely of '1', followed by the start bit of the next frame containing the data. Set TXEN bit of USART_CTRL1 register to 1 and one idle frame can be set before the first data frame.

22.4.4 Receiver

22.4.4.1 Character receive

During receiving period of USART, RX pin will first introduce the least significant bit of the data. In this mode, USART_RXDATA register has a buffer between the internal bus and the receive shift register. The data is transmitted to the buffer bit by bit. When fully receiving the data, the corresponding receive register is not empty, then the user can read USART_RXDATA.

Receiving configuration steps

- (1) The programming oversampling rate is 8 or 16 times
- (2) Decide the word length by setting DBLCFG bit of USART_CTRL1 register
- (3) Decide the number of stop bits by setting STOPCFG bit of USART_CTRL2 register
- (4) Set UEN bit of USART_CTRL1 register to enable USART
- (5) If multi-buffer communication is selected, DMA should be enabled in USART_CTRL3 register
- (6) Set the baud rate of communication in USART_BR register
- (7) Set RXEN bit of USART_CTRL1 to enable receiving

Note:

- (1) RXEN bit cannot be reset during data receiving period; otherwise, the bytes being received will be lost.
- (2) In the process when the receiver is receiving a data frame, if overrun error, noise error or frame error is detected, the error flag will be set to 1.
- (3) When data is transferred from the shift register to USART_RXDATA register, the RXBNEFLG bit of USART_STS will be set by hardware.
- (4) An interrupt will be generated if RXBNEIEN bit is set.
- (5) In single buffer mode, the RXBNEFLG bit can be cleared by reading USART_RXDATA register by software or by writing 0.
- (6) In multi-buffer mode, after each byte is received, RXBNEFLG bit of USART_STS register will be set to 1, and DMA will read the data register to clear it.

22.4.4.2 Break frame

When the receiver receives a break frame, USART will handle it as receiving a frame error.

22.4.4.3 Idle frame

When the receiver receives an idle frame, USART will handle it as receiving an ordinary data frame; if IDLEIEN bit of USART_CTRL1 is set, an interrupt will be generated.

22.4.4.4 Select the clock source

The clock source must be selected by clock control system before USART is enabled

- (1) The clock source is selected according to the transmission speed and the possibility of use of USART in low-power mode.

- (2) The clock source frequency is f_{CK} .
- The range of communication speed is determined by the clock source. USART should be enabled before the clock source is selected.
 - When USART adopts dual clock domain or wakes up the stop mode, PCLK, LSECLK, HSICLK or SYSCLK can be the clock source; otherwise, the clock source is PCLK.
 - If LSECLK and LSICLK are selected as the clock source, USART can receive data even in low-power mode. And it can select according to the received data and wake-up mode, and wake up MCU when necessary, so that DMA can read the received data.
 - The receiver realizes the data recovery of different oversampling technologies configured by users to distinguish valid incoming data and noises, which requires a trade-off between the maximum communication speed and noise/clock inaccuracy immunity.

22.4.4.5 Oversampling rate

OSMCFG bit of USART_CTRL1 register determines the oversampling rate. If the oversampling rate is 8 times of the baud rate, the speed is higher, but the clock tolerance is smaller. If it is 16 times, the speed is lower, but the clock tolerance is bigger.

22.4.4.6 Overrun error

When RXBNEFLG bit of USART_STS register is set to 1 and a new character is received at the same time, an overrun error will be caused. Only after RXEN is reset, can the data be transferred from the shift register to RXDATA register. RXBNEFLG bit will be set to 1 after receiving the byte. This bit needs to be reset before receiving the next data or serving the previous DMA request; otherwise, an overrun error will be caused.

When an overrun error occurs

- OVREFLG bit of USART_STS is set to 1
- The data in RXDATA register will not be lost
- The data in the shift register received before will be overwritten, but the data received later will not be saved
- If RXBNEIEN bit or ERRIEN bit of USART_CTRL1 is set, an interrupt will be generated
- When OVREFLG bit is set, it means there are data lost. There are two possibilities:
 - When RXBNEFLG=1, the previous valid data is still on RXDATA register, and can be read
 - When RXBNEFLG=0, there is no valid data in RXDATA register.
- The OVREFLG bit can be reset through read operation for USART_STS and USART_RXDATA registers.

22.4.4.7 Noise error

When noise is detected in receiving process of the receiver:

- Set NEFLG flag on the rising edge of RXBNEFLG bit of USART_STS register
- Invalid data is transmitted from the shift register to USART_RXDATA register.
- In single byte communication, there is no interrupt, but in multi-buffer communication, an interrupt will be generated by setting the ERRIEN bit of USART_CTRL3 register

Note: 8-time oversampling ratio cannot be used in LIN, smart card and IrDA modes.

22.4.4.8 Frame error

If the stop bit is not received and recognized at the expected receiving time due to excessive noise or lack of synchronization, a frame error will be detected.

When a frame error is detected in receiving process of the receiver:

- Set the FEFLG bit of USART_STS register
- Invalid data is transmitted from the shift register to USART_RXDATA register.
- In single byte communication, there is no interrupt, but in multi-buffer communication, an interrupt will be generated by setting the ERRIEN bit of USART_CTRL3 register

22.4.5 Tolerance of Receiver to the Change of Clock

Only when the total clock system deviation is less than the tolerance of USART receiver, can the USART receiver work normally.

Deviation will occur in any of the following circumstances:

- (1) DTRA: Deviation caused by transmitter error
- (2) DQUANT: Deviation caused by receiver baud rate quantization
- (3) DREC: Change of receiver oscillator
- (4) DTCL: Deviation caused by transmission line

22.4.6 Baud Rate Generator

The baud rate division factor (USARTDIV) is a 16-digit number consisting of 12-digit integer part and 4-digit decimal part. Its relationship with the system clock:

Baud rate = $PCLK / 16 \times (USARTDIV)$

The system clock of USART2/3 is PCLK1, and that of USART1 is PCLK2. USART can be enabled only after the clock control unit enables the system clock.

22.4.7 Automatic Baud Rate Detection

When a character is received, USART can detect and automatically set the value of the USART_BR register. Automatic baud rate detection is conducted when the communication speed of the system is unknown, when the clock source with low precision is used, or when the clock deviation is not measured to obtain the correct bit rate. The clock source must be compatible with the expected communication speed.

A non-zero baud rate must be written for initialization; confirm the character content, and then turn on automatic baud rate detection. ABRDCFG bit of USART_CTRL2 register can be set to select the character content, and the possible character content is:

- (1) For all characters starting with 1, in this case, measure the length of the start bit (the duration from the falling edge to the rising edge).

- (2) For all characters starting with 10xx, in this case, measure the length of the start bit and the first data bit, the duration of the falling edge, to ensure better accuracy when the signal slew rate is small.
- (3) One 0x7F character frame (it can be 0x7F in the first mode of LSB, or 0xFE character in the first mode of MSB). In this case, first detect the baud rate of start bit, then take samples of the bit[6:0] at the end of the Bit 6, and further take samples of the bit rate of the character of bit[6].
- (4) A 0x55 character frame; in this case, first detect the baud rate of the start bit, then detect the baud rate at the end of Bit 0 data, and finally detect the baud rate at the end of Bit 6 data. Take samples in bit[0], bit[6:1] and bit[6] respectively.

ABRDEN bit of USART_CTRL2 register determines whether to turn on automatic baud rate detection. After the automatic baud rate detection is turned on, wait for the first character on RX line. After detection, ABRDFLG flag bit of USART_STS register will be set.

Note:

- (1) If the line noise is too high, correct baud rate cannot be guaranteed. In this case, the BR value may be damaged and the ABRDFLG flag bit will be set. This situation can also happen if the communication speed and automatic baud rate detection is not compatible.
- (2) RXBNEFLG interrupt will be generated after detection.
- (3) At any time, automatic baud rate detection may be restarted by resetting the ABRDFLG flag (writing a 0).
- (4) USART cannot be disabled during automatic baud rate detection; otherwise, the BR value may be damaged.

22.4.8 Multi-processor Communication

In multi-processor communication, multiple USARTs are connected to form a network. In this network, two devices communicate with each other, and the mute mode can be enabled for other devices not participating in the communication in order to reduce the burden of USART. In mute mode, the LINMEN bit of USART_CTRL2 register, and the SCEN bit, IREN bit and HDEN bit of USART_CTRL3 register are cleared, any receive state bit will not be set, and all receive interrupts will be disabled.

When mute mode is enabled, there are two ways to exit the mute mode:

- (1) WUPMCFG bit is cleared and the bus is idle to exit the mute mode.
- (2) WUPMCFG bit is set and after receiving the address flag, it can exit the mute mode.

Idle bus detection (WUPMCFG=0)

When RXWFMUTE is set to 1, USART enters the mute mode, and it can be waken up from the mute mode when an idle frame is detected, meanwhile, the RXWFMUTE bit will be cleared by the hardware. RXWFMUTE can also be cleared by software.

Figure 93 Idle Bus Exit Mute Mode

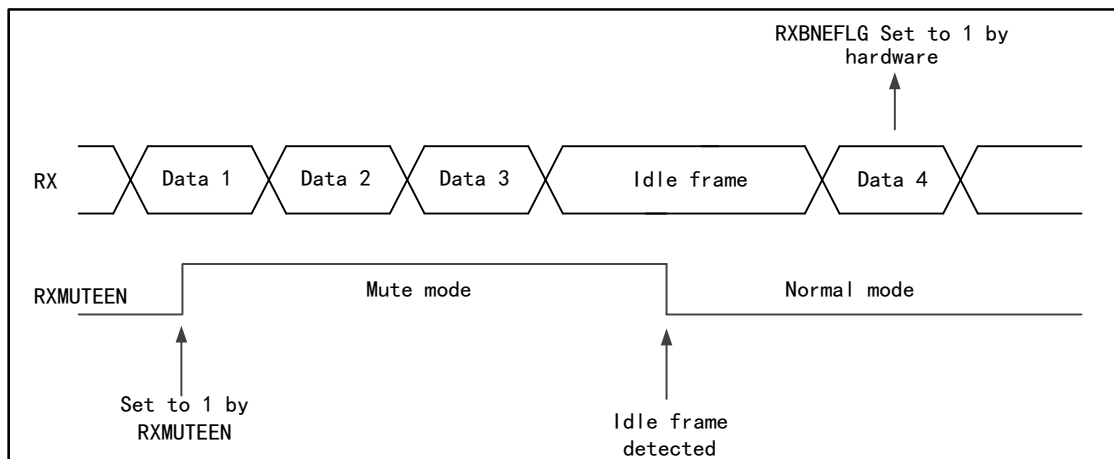

Address flag detection (WUPMCFG=1)

If the address flag bit is 1, this byte is regarded as the address. The storage address of lower four bits of the address bytes will first be compared with its own address when the receiver receives the address byte. If the addresses do not match, the receiver will enter the mute mode. If the addresses match, the receiver will wake up from the mute mode and be ready to receive the next byte. If the address byte is received again after exiting the mute mode, but the address does not match its own address, the receiver will enter the mute mode again.

Figure 94 Address Flag Exit Mute Mode

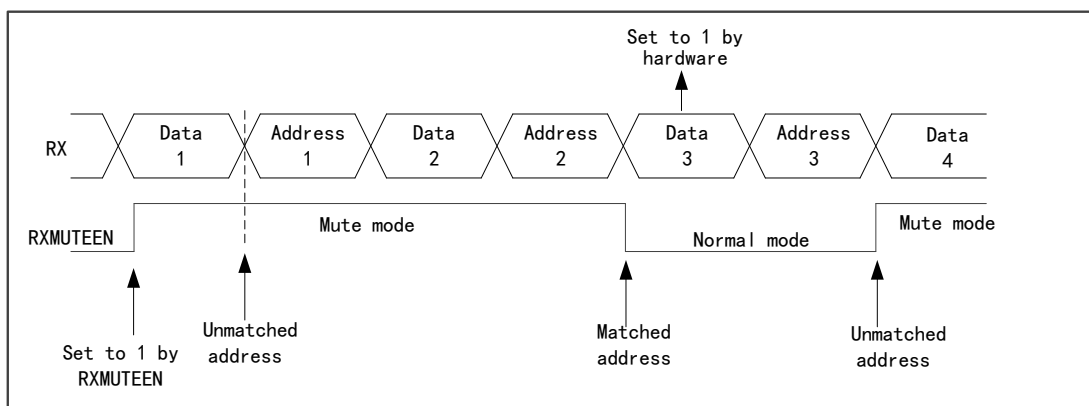

22.4.9 Wake up from the Stop Mode

When USART uses HSICLK and LSECLK as clock source, USWMEN bit of USART_CTRL1 register decides whether to wake up from the stop mode. Before entering the stop mode, set USWMEN bit of USART_CTRL1 register, and when wake-up time is detected, set WSMFLG to 1, and at this time, an interrupt will be generated as long as WSMIEN is set.

Mute mode in stop mode

It is not allowed to exit from the mute mode during idle detection. If the system exits the mute mode by using the address matching, only the address matching event can be taken as its wake-up source. If the start bit is set to detect wake-up,

WSMFLG is set and RXBNEFLG flag bit is not set.

22.4.10 Synchronous Mode

The synchronous mode supports full duplex synchronous serial communication in master mode, and has one more signal line USART_CK which can output synchronous clock than the asynchronous mode.

CLKEN bit of USART_CTRL2 register decides whether to enter the synchronous mode.

When USART enters the synchronous mode:

- The LINMEN bit of USART_CTRL2 register, and IREN, HDEN and SCEN bits of USART_CTRL3 registers must be cleared
- The start bit and stop bit of the data frame have no clock output
- Whether the last data bit of the data frame generates USART_CK clock is determined by LBCPOEN bit of the register USART_CTRL2
- The clock polarity of USART_CK is decided by CPOL bit of USART_CTRL2 register
- The phase of USART_CK is decided by CPHA bit of USART_CTRL2
- The external CK clock cannot be activated when the bus is idle or the frame is disconnected

Figure 95 USART Synchronous Transmission Example

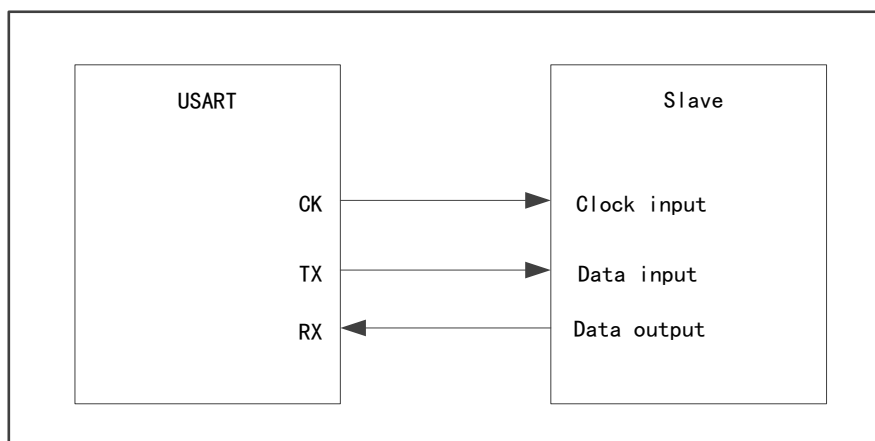

Figure 96 USART Synchronous Transmission Timing Diagram (DBLCFG=10)

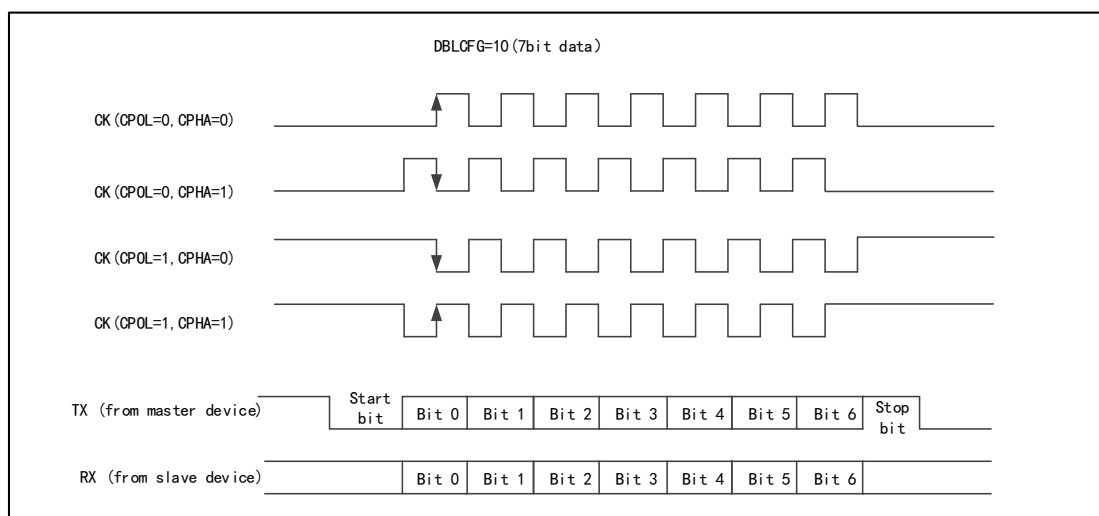

Figure 97 USART Synchronous Transmission Timing Diagram (DBLCFG=00)

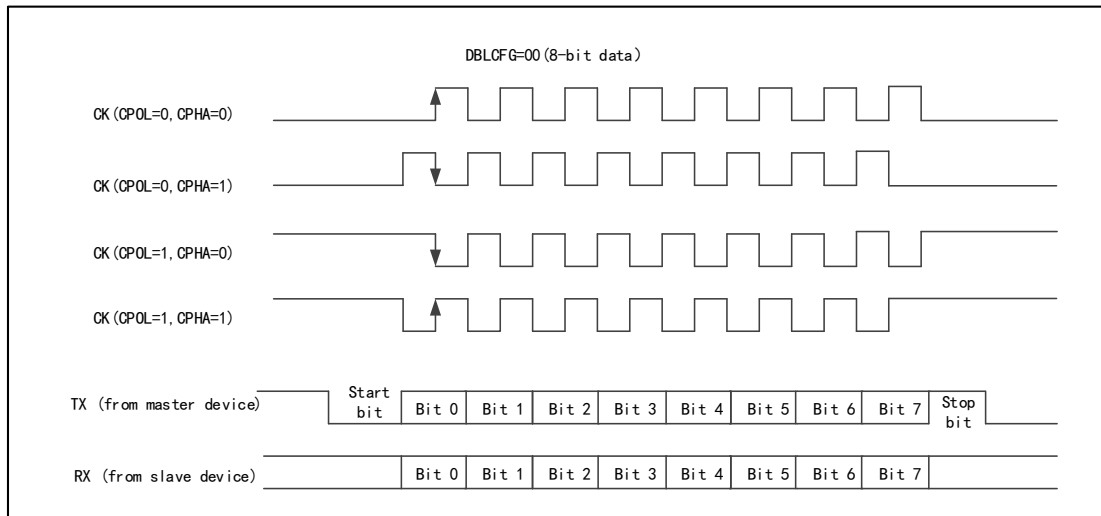
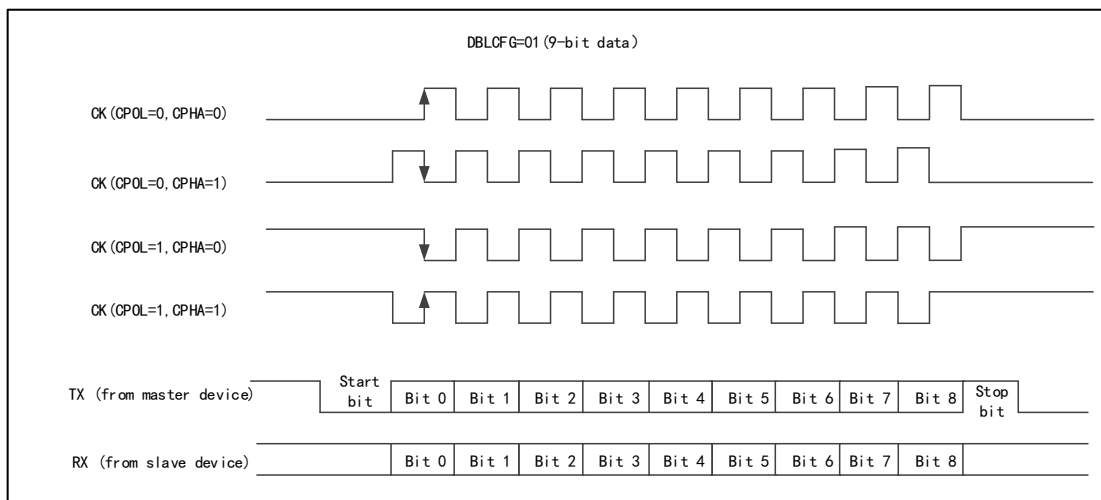

Figure 98 USART Synchronous Transmission Timing Diagram (DBLCFG=01)



22.4.11 LIN Mode

LINMEN bit of USART_CTRL2 register decides whether to enter LIN mode.

When entering LIN mode:

- All data frames are 8 data bits and 1 stop bit
- The CLKEN bit and STOPCFG bit of USART_CTRL2 register and IREN bit, HDEN bit and SCEN bit of USART_CTRL3 register need to be cleared

In LIN master mode, USART can generate break frame, and the detection length of break frame can be set to 10 bits and 11 bits through LBDLCFG bit of USART_CTRL2. The break frame detection circuit is independent of USART receiver, and no matter in idle state or in data transmission state, RX pin can detect the break frame, and LBDLFLG bit of USART_STS register is set to 1; at this time, if LBDIEN bit of USART_CTRL2 is enabled, an interrupt will be generated.

Detection of break frame in idle state

In idle state, if a break frame is detected on RX pin, the receiver will receive a data frame of 0 and generate FEFLG error.

Figure 99 Break Frame Detection in Idle State

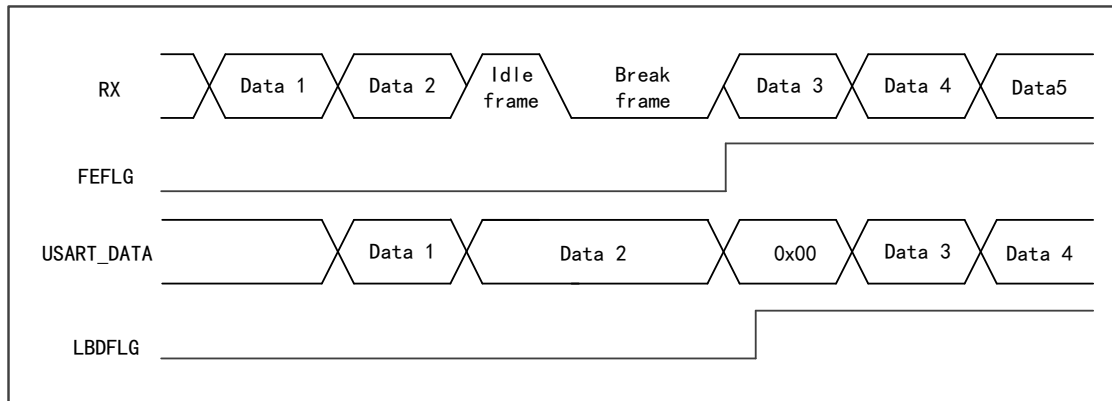

Detection of break frame in data transmission state

In the process of data transmission, if the RX pin detects the break frame, the currently transmitted data frame will generate FEFLG error.

Figure 100 Break Frame Detection in Data Transmission State

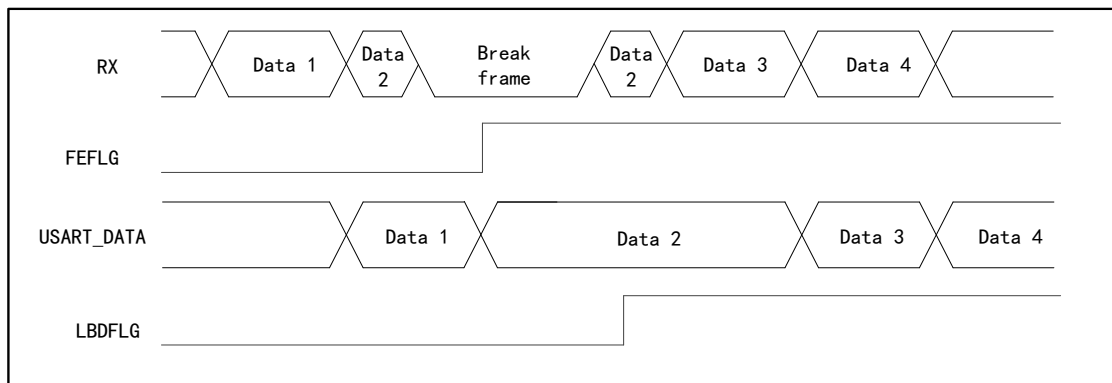

22.4.12 Smart Card Mode

Smart card mode is a single-line half-duplex communication mode. The interface supports ISO7816-3 standard protocol and can control the reading and writing of smart cards that meet the standard protocol.

SCEN bit of USART_CTRL3 register decides whether to enter the smart card mode.

When USART enters the smart card mode:

- The LINMEN bit of USART_CTRL2 register, and IREN and HDEN bits of USART_CTRL3 register must be cleared
- The data frame format is 8 data bits and 1 check bit, and 0.5 or 1.5 stop bits are used
- CLKEN bit of USART_CTRL2 can be set to provide clocks for smart card

- During the communication, when the receiver detects a parity error, in order to inform the transmitter that the data has not been received successfully, the data line will be pulled down after half a baud rate clock, and keep pulling down for one baud rate clock
- The break frame has no meaning in smart card mode. A 00h data with frame error will be regarded as a data instead of disconnection symbol

Figure 101 ISO7816-3 Standard Protocol

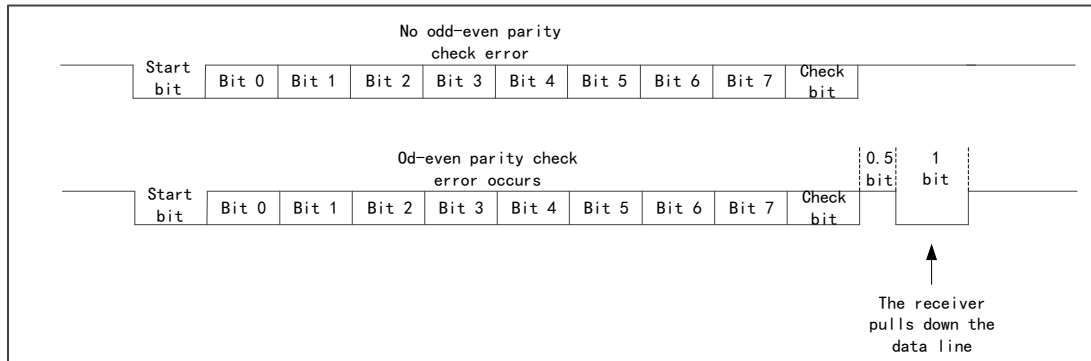

22.4.13 Infrared (IrDA SIR) Function Mode

IrDA mode is a half-duplex protocol, transmitting and receiving data can not be carried out at the same time, and the delay between data transmitting and receiving should be more than 10ms.

IREN bit of USART_CTRL3 register decides whether to enter the IrDA mode.

When USART enters the IrDA mode:

- The CLKEN bit, STOPCF bit and LINMEN bit of USART_CTRL2 register and HDEN bit and SCEN bit of USART_CTRL3 register must be cleared.
- The data frame uses 1 stop bit and the baud rate is less than 115200Hz.
- Using infrared pulse (RZI) indicates logic '0', so in normal mode, its pulse width is 3/16 baud rate cycles. When IrDA is in low mode, it is recommended that the pulse width be greater than three DIV frequency division clocks so as to ensure that this pulse can be detected by IrDA normally.

Figure 102 IrDA Mode Block Diagram

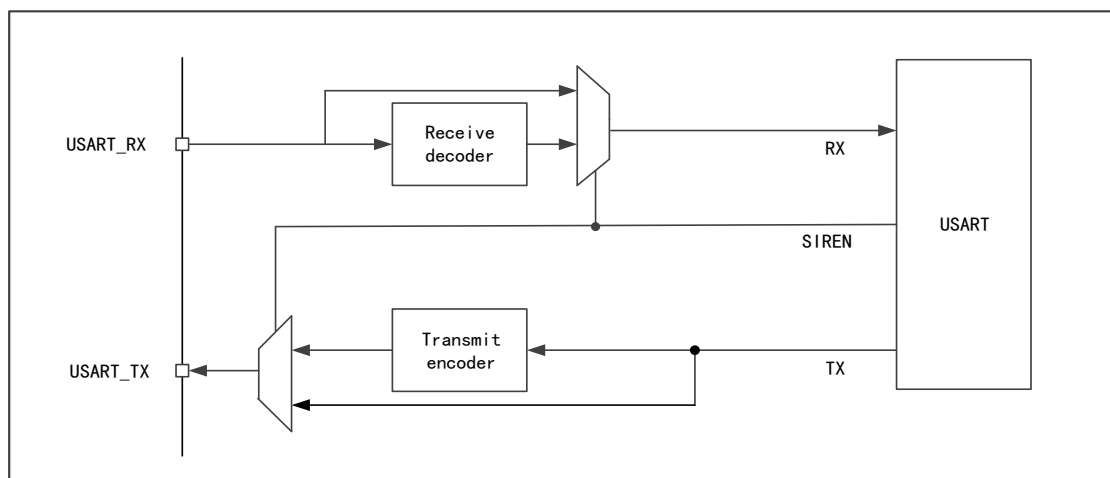

22.4.14 Hardware Flow Control and RS485 Drive Enable

The function of hardware flow control is to control the serial data flow between two devices through nCTS pin and nRTS pin.

Figure 103 Hardware Flow Control between Two USARTs

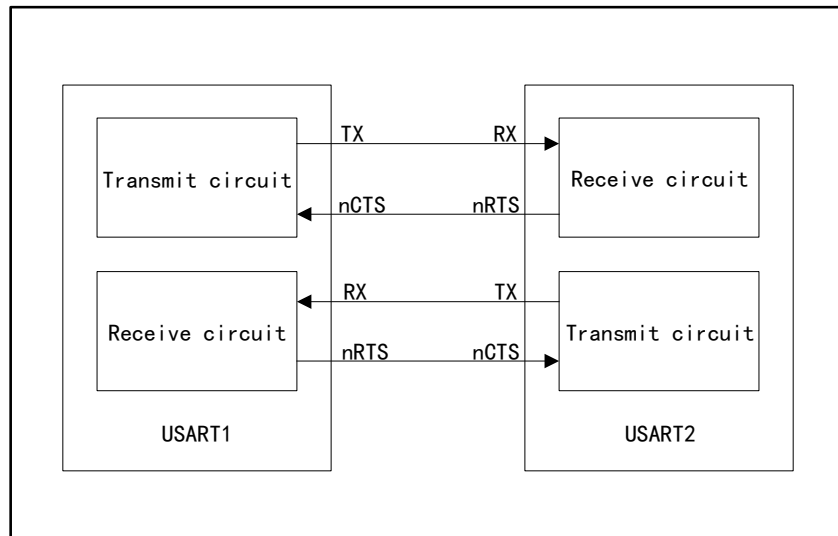

CTS flow control

CTSEN bit of USART_CTRL3 register determines whether CTS flow control is enabled. If CTS flow control is enabled, the transmitter will detect whether the data frame of nCTS pin can be transmitted. If TXBEFLG bit=0 for USART_STS register and nCTS is pulled to low level, the data frame can be transmitted. If nCTS becomes high during transmission, the transmitter will stop transmitting after the current data frame is transmitted.

RTS flow control

RTSEN bit of USART_CTRL3 register determines whether RTS flow control is enabled. If RTS flow control is enabled, when the receiver receives data, nRTS will be pulled to low level. When a data frame is received, nRTS will become high to inform the transmitter to stop transmitting data frame.

RS485 driver enable

DEN bit of USART_CTRL3 register determines whether to turn on the driver enable function, and this function can allow DE signal to turn on the control terminal of the external transceiver.

Lead time: The time interval between the driver enable signal and the start bit of the first byte. Controlled by DLTEN[4:0] of USART_CTRL1 controller.

Lag time: The time interval between the stop bit of the last byte and the release DE signal. Controlled by DDLTEN[4:0] of USART_CTRL1 register.

22.4.15 DMA Multi-processor Communication

USART can access the data buffer in DMA mode in order to reduce the burden of processors.

Transmission in DMA mode

DMATXEN bit of USART_CTRL3 register determines whether to transmit in DMA mode. When transmitting by DMA, the data in the designated SRAM will be transmitted to the buffer by DMA.

Configuration steps of transmission by DMA:

- (1) Clear the TXCFLG flag bit of USART_STS register
- (2) Set the address of SRAM memory storing data as DMA source address
- (3) Set the address of USART_TXDATA register as DMA destination address
- (4) Set the number of data bytes to be transmitted
- (5) Set channel priority
- (6) Set interrupt enable
- (7) Enable DMA channel
- (8) Wait for TXCFLG position 1 of USART_STS register, indicating transmission completion

Receive in DMA mode

DMARXEN bit of USART_CTRL3 register determines whether to receive by DMA. When receiving by DMA, every time one byte is received, the data in the receive buffer will be transmitted to the designated SRAM area by DMA.

Configuration steps of receiving by DMA:

- (1) Set the address of USART_RXDATA register as DMA source address
- (2) Set the address of SRAM memory storing data as DMA destination address
- (3) Set the number of data bytes to be transmitted
- (4) Set channel priority
- (5) Set interrupt enable
- (6) Enable DMA channel

22.4.16 Modbus Communication

USART supports ModBus/RTU and ModBus/ASCII protocols, and ModBus/RTU is a half duplex block transmission protocol. Control part of the protocol can be realized only in software. USART supports end of block detection, not requiring software or other condition.

22.4.16.1 ModBus/RTU

This function can be realized through programmable timeout function. In this mode, the end of one block is regarded as one free line with the length greater than two characters. RXTOIEN bit of USART_CTRL1 register and RXTODEN bit of USART_CTRL2 register control the timeout function and corresponding interrupts. Write a timeout number to USART_RXTO register, and when the idle state of the receiving line reaches this length, an interrupt will be generated, indicating the completion of block receiving.

22.4.16.2 Modbus/ASCII

In this mode, the end of one block is identified by one specific (CR/LF) character sequence. USART uses character matching function to manage this mechanism. Program ASCII code of LF in ADDR[7:0] field and activate this character to match the interrupt (CMIEN=1). When a LF character is received, the software will be informed to check CR/LF in DMA buffer.

22.4.17 Interrupt Request

Table 69 USART Interrupt Request

Interrupt event		Event flag bit	Enable bit
The receive register cannot be empty		RXBNEFLG	RXBNEIEN
Overload error		OVREFLG	
Line idle is detected		IDLEFLG	IDLEIEN
Odd-even parity error		PEFLG	PEIEN
LIN disconnection error		LBDFLG	LBDIEN
Receiving error in DMA mode	Noise error	NEFLG	ERRIEN
	Overrun error	OVREFLG	
	Frame error	FEFLG	
Matching character		CMFLG	CMIEN
Error of failing to receive on time		RXTOFLG	RXTOIEN
End of block is detected		EOBFLG	EOBIEN
Stop mode	Wake up from the stop mode	WSMFLG	WSMIEN
Transmit data register is empty		TXBEFLG	TXBEIEN
Transmission is completed		TXCFLG	TXCIEN
CTS flag		CTSFLG	CTSIEN

All interrupt requests of USART are connected to the same interrupt controller, and the interrupt requests have logical or relational before they are transmitted to the interrupt controller.

Figure 104 USART Interrupt Mapping

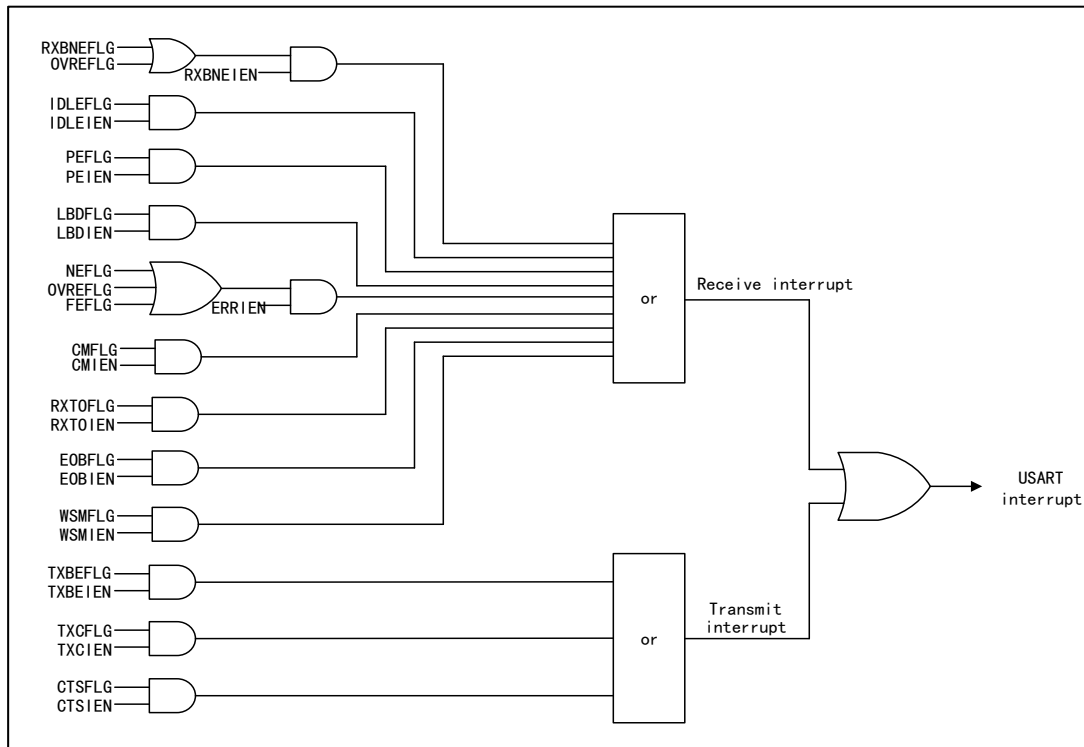

22.4.18 Comparison of USART Supporting Functions

Table 70 Comparison of USART Supporting Functions

USART mode	USART1	USART2	USART3	USART4
Half duplex (single-line mode)	√	√	√	√
Support the automatic baud rate detection mode	4	4	—	—
Multi-processor communication	√	√	√	√
Dual clock domain and wake-up from the stop mode	√	√	—	—
Synchronous	√	√	√	√
LIN	√	√	—	—
Smart card	√	√	—	—
IrDA	√	√	—	—
Hardware flow control	√	√	√	√
RS485 driver enable	√	√	√	√
Multi-cache communication (DMA)	√	√	√	√
Receiving timeout interrupt	√	√	—	—
Modbus communication	√	√	—	—

Note:

(1) “√” means this function is supported, while “—” means that this function is not supported.

22.5 Register Address Mapping

Table 71 USART Register Address Mapping

Register name	Description	Offset address
USART_CTRL1	Control register 1	0x00
USART_CTRL2	Control register 2	0x04
USART_CTRL3	Control register 3	0x08
USART_BR	Baud rate register	0x0C
USART_GTPSC	Protection time and prescaler register	0x10
USART_RXTO	Receive timeout register	0x14
USART_REQUEST	Request register	0x18
USART_STS	Interrupt and state register	0x1C
USART_INTFCLR	Interrupt flag clear register	0x20
USART_RXDATA	Receive data register	0x24
USART_TXDATA	Transmit data register	0x28

22.6 Register Functional Description

22.6.1 Control register 1 (USART_CTRL1)

Offset address: 0x00

Reset value: 0x0000

Field	Name	R/W	Description
0	UEN	R/W	<p>USART Enable</p> <p>0: USART frequency divider and output are disabled</p> <p>1: USART module is enabled</p> <p>It is set to 1 or cleared by software; clearing this bit will cancel the current operation and the prescaler and output of USART will stop working immediately. The setting for USART will not be reset, but the state flag in USART_STS will be reset.</p>
1	USWMEN	R/W	<p>USART in Stop Mode Wake Up MCU Enable</p> <p>0: Disable</p> <p>1: Enable</p> <p>This bit can be set to 1 and cleared by software: To set this bit, it is required to select HSICLK or LSECLK as the clock source of USART (see Chapter RCM)</p>
2	RXEN	R/W	<p>Receive Enable</p> <p>0: Disable</p> <p>1: Enable, and start to detect the start bit on RX pin</p> <p>Set 1 or clear 0 by software.</p>
3	TXEN	R/W	<p>Transmitte Enable</p> <p>0: Disable</p> <p>1: Enable</p> <p>Set 1 or clear 0 by software.</p>

Field	Name	R/W	Description
4	IDLEIEN	R/W	IDLE Interrupt Enable 0: Disable 1: Generate an interrupt when IDLEFLG is set Set 1 or clear 0 by software.
5	RXBNEIEN	R/W	Receive Buffer Not Empty Interrupt Enable 0: Disable 1: Generate an interrupt when OVREFLG or RXBNEFLG is set Set 1 or clear 0 by software.
6	TXCIEN	R/W	Transmit Complete Interrupt Enable 0: Disable 1: Generate an interrupt when TXCFLG is set Set 1 or clear 0 by software.
7	TXBEIEN	R/W	Transmit Buffer Empty Interrupt Enable 0: Disable 1: Generate an interrupt when TXBEFLG is set Set 1 or clear 0 by software.
8	PEIEN	R/W	Parity Error interrupt Enable 0: Disable 1: Generate an interrupt when PEFLG is set Set 1 or clear 0 by software.
9	PCFG	R/W	Odd/Even Parity Configure 0: Even parity check 1: Odd parity check Set 1 or clear 0 by software. The selection will not take effect until the current transmission of bytes is completed. This bit can be set only when USART is not enabled.
10	PCEN	R/W	Parity Control Enable 0: Disable 1: Enable If this bit is set, a check bit will be inserted in the most significant bit when transmitting data; when receiving data, check whether the check bit of the received data is correct. The check control will not take effect until the current transmission of bytes is completed. This bit can be set only when USART is not enabled.
11	WUPMCFG	R/W	Wakeup Method Configure 0: Idle bus wakeup 1: Address tag wakeup Set 1 or clear 0 by software. This bit can be set only when USART is not enabled.
12	DBLCFG0	R/W	Data Bits Length Configure This bit and DBLCFG1 bit jointly decide the length of data bit. Set 1 or clear 0 by software. This bit cannot be modified during transmission of data.
13	RXMUTEEN	R/W	Receive Mute Mode Enable 0: Normal working mode 1: Can switch between normal mode and mute mode Set 1 or clear 0 by software.

Field	Name	R/W	Description
14	CMIEN	R/W	Character Match Interrupt Enable 0: Disable 1: Generate an interrupt when CMFLG is set Set 1 or clear 0 by software.
15	OSMCFG	R/W	Oversampling Mode Configure 0: 16-time oversampling 1: 8-time oversampling This bit can be set only when USART is not enabled.
20:16	DDLTEN[4:0]	R/W	Driver De-lead Time Enable This bit field is the time interval between the last stop bit and DE signal during transmission. Its unit is sampling time, determined by oversampling rate. If write operation is performed for USART_TXDATA within DDLTEN time, the just written data will be transmitted only after DDLTEN and DLTEN time. This bit field can be set only when USART is not enabled.
25:21	DLTEN[4:0]	R/W	Driver Lead Time Enable This bit field is the time interval between DE signal and the first start bit during transmission. Its unit is sampling time, determined by oversampling rate. This bit field can be set only when USART is not enabled.
26	RXTOIEN	R/W	Receiver Timeout Interrupt Enable 0: Disable 1: Generate an interrupt when RXTOFLG is set Set or cleared by software.
27	EOBIEN	R/W	End of Block Interrupt Enable This bit can be set to 1 and cleared by software. 0: Disable 1: Generate an interrupt when EOBFLG is set Set or cleared by software.
28	DBLCFG1	R/W	Data Bits Length Configure This bit and DBLCFG0 bit jointly decide the length of data bit. DBLCFG[1:0]=00: 1 start bit, 8 data bits, n stop bits DBLCFG[1:0]=01: 1 start bit, 9 data bits, n stop bits DBLCFG[1:0]=10: 1 start bit, 7 data bits, n stop bits Set 1 or clear 0 by software. This bit cannot be modified during transmission of data.
31:29	Reserved		

22.6.2 Control register 2 (USART_CTRL2)

Offset address: 0x04

Reset value: 0x0000

Field	Name	R/W	Description
3:0	Reserved		
4	ADDRLEN	R/W	Slave Address Length Configure 0: 4-bit address 1: 7-bit address This bit field can be set only when USART is not enabled.
5	LBDLCFG	R/W	LIN Break Detection Length Configure 0: 10 bits

Field	Name	R/W	Description
			1: 11 bits This bit can be set only when USART is not enabled.
6	LBDIEN	R/W	LIN Break Detection Interrupt Enable 0: Disable 1: Generate an interrupt when LBDIFLG bit is set.
7	Reserved		
8	LBCPOEN	R/W	Last Bit Clock Pulse Output Enable 0: Not output from CK 1: Output from CK This bit is valid only in synchronous mode. This bit can be set only when USART is not enabled.
9	CPHA	R/W	Clock Phase Configure This bit indicates on the edge of which clock sampling is conducted 0: The first 1: The second This bit is valid only in synchronous mode. This bit can be set only when USART is not enabled.
10	CPOL	R/W	Clock Polarity Configure The state of CK pin when USART is in idle state 0: Low level 1: High level This bit is valid only in synchronous mode. This bit can be set only when USART is not enabled.
11	CLKEN	R/W	Clock Enable (CK pin) 0: Disable 1: Enable This bit can be set only when USART is not enabled.
13:12	STOPCFG	R/W	STOP Bit Configure 00: 1 stop bit 01: 0.5 stop bit 10: 2 stop bits 11: 1.5 stop bits This bit can be set only when USART is not enabled.
14	LINMEN	R/W	LIN Mode Enable 0: Disable 1: Enable Set or cleared by software. In LIN mode, TXBFQ bit can be set to transmit and detect LIN synchronous disconnection character. This bit can be set only when USART is not enabled.
15	SWAPEN	R/W	Swap TX/RX Pins Function Enable 0: Use according to standard allocation 1: The functions of TX and RX pins can be exchanged for use, and they will work when crossing and interconnecting with other USART. Set or cleared by software. This bit can be set only when USART is not enabled.
16	RXINVEN	R/W	RX Pin Active Level Inversion Enable 0: Standard logic level ($V_{DD}=1/IDLE$, $Gnd=0/mark$) 1: Reverse direction ($V_{DD}=0/mark$, $Gnd=1/IDLE$), which works when there is an external phase inverter on RX line. Set or cleared by software.

Field	Name	R/W	Description
			This bit can be set only when USART is not enabled.
17	TXINVEN	R/W	TX Pin Active Level Inversion Enable 0: Standard logic level ($V_{DD}=1$ /IDLE, Gnd=0/mark) 1: Reverse direction ($V_{DD}=0$ /mark, Gnd=1/IDLE), which works when there is an external phase inverter on TX line. Set or cleared by software. This bit can be set only when USART is not enabled.
18	BINVEN	R/W	Binary Data Inversion Enable 0: Positive/Direct logic (0=L, 1=H) 1: Negative/Reverse logic (0=H, 1=L) Set or cleared by software. This bit can be set only when USART is not enabled. The check bit will be inverted when this bit is set.
19	MSBFEN	R/W	Most Significant Bit First Enable 0: The data of No. 0 bit immediately follows the start bit 1: The data of the most significant bit immediately follows the start bit Set or cleared by software. This bit can be set only when USART is not enabled.
20	ABRDEN	R/W	Auto Baud Rate Detection Enable 0: Disable 1: Enable Set or cleared by software.
22:21	ABRD CFG	R/W	Auto Baud Rate Detection Mode Configure 00: Measure the start bit 01: Measure the falling edge 10: 0x7F frame detection 11: 0x55 frame detection Set or cleared by software.
23	RXTODEN	R/W	Receive Timeout Detection Function Enable 0: Disable 1: Enable Set or cleared by software. Set this bit, and when it is detected that the RX line is idle for the length of time configured by RXTO register, the RXTOFLG bit will be set by hardware.
27:24	ADDR L	R/W	USART Device Node Address Low Setup This bit field is used for wake-up detection of 7-bit address flag which is used for multi-computer communication and enters the mute state or stop mode. This bit can be set only when the receiver is turned off or USAR is not enabled.
31:28	ADDR H	R/W	USART Device Node Address High Setup This bit field is not only used for wake-up detection of 7-bit address flag which is used for multi-computer communication and enters the mute state or stop mode. (The most significant bit of the character of the transmitter should be 1) But is also used for character detection in normal receiving process. (Then the mute state is disabled) Then if the received 8-bit byte matches ADDR H, CMFLG bit will be set. This bit can be set only when the receiver is turned off or USAR is not enabled.

22.6.3 Control register 3 (USART_CTRL3)

Offset address: 0x08

Reset value: 0x0000

Field	Name	R/W	Description
0	ERRIEN	R/W	Error interrupt Enable 0: Disable 1: Enable; when any bit among FEFLG, OVREFLAG and NEFLAG is set, an interrupt will be generated.
1	IREN	R/W	IrDA Function Enable 0: Disable 1: Enable Set or cleared by software. This bit can be set only when USART is not enabled.
2	IRLPEN	R/W	IrDA Low-power Mode Enable 0: Normal mode 1: Low-power mode This bit can be set only when USART is not enabled.
3	HDEN	R/W	Half-duplex Mode Enable 0: Disable 1: Enable This bit can be set only when USART is not enabled.
4	SCNACKEN	R/W	NACK Transmit Enable During Parity Error in Smartcard Function 0: NACK is not transmitted 1: Transmit NACK This bit can be set only when USART is not enabled.
5	SCEN	R/W	Smartcard Function Enable 0: Disable 1: Enable This bit can be set only when USART is not enabled.
6	DMARXEN	R/W	DMA Receive Enable 0: Disable 1: Enable Set or cleared by software.
7	DMATXEN	R/W	DMA Transmit Enable 0: Disable 1: Enable Set or clear by software.
8	RTSEN	R/W	RTS Function Enable 0: Disable 1: Enable RTS interrupt RTS: Require To Send, which is output signal, indicating it has been ready to receive. Request is made to receive data only when there is space in the receive buffer; when data can be received, RTS output is pulled to low level. This bit can be set only when USART is not enabled.
9	CTSEN	R/W	CTS Function Enable 0: Disable 1: Enable CTS: Clear To Send, which is input signal When CTS input signal is at low level, the data can be transmitted; otherwise, the data cannot be transmitted; if CTS signal is pulled to high during data transmission, the data transmission will be stopped after the data transmission is completed; if write operation is performed for the data register when CTS is high, the data will not be transmitted until CTS is valid. This bit can be set only when USART is not enabled.
10	CTSIEN	R/W	CTS Interrupt Enable 0: Disable 1: Generate an interrupt when CTSFLAG is set

Field	Name	R/W	Description
11	SAMCFG	R/W	Sample Method Configure 0: Sampling for three times 1: Single sample; flag of noise detection disabled This bit can be set only when USART is not enabled.
12	OVRDEDIS	R/W	Overrun Detection Disable 0: Enable When RXBNEFLG bit is set and new data is received, OVREFLG bit will be set. 1: Disable. When new data are received, if RXBNEFLG is still set but OVREFLG is not set, the data not read will be covered by new data. This bit can be set only when USART is not enabled.
13	DDISRXEEN	R/W	DMA Disable on Receive Error Enable 0: DMA not disabled. The corresponding error flag bit will be set, but in order to avoid data from overrunning and being covered, RXBNEFLG will not be set. In smart card mode, as a result, no DMA request will be issued, so wrong data will not be transmitted, but the next correct data will be transmitted. 1: DMA disabled. If RXBNEFLG is set, the corresponding error flag bit will also be set. DMA request will not be masked only when the corresponding error flag bit is cleared. Therefore, it is required to first disable DMA request or first clear RXBNEFLG flag and then clear the error flag. This bit can be set only when USART is not enabled.
14	DEN	R/W	Driver Enable Users are allowed to activate the control terminal of external transceiver through DE signal. 0: DE function disabled 1: DE function enabled, DE signal output on RTS pin This bit can be set only when USART is not enabled.
15	DPCFG	R/W	Driver Polarity Configure 0: DE signal high level is valid 1: DE signal low level is valid This bit can be set only when USART is not enabled.
16	Reserved		
19:17	SCARCCFG	R/W	Smartcard Mode Auto-retry Count Configure 0x0: Disable the retransmission function and data will not be retransmitted in transmission mode. 0x1~0x7: The number of automatic retry times Transmission mode: The number of times of automatic retransmission of data before transmission error is generated. Receiving mode: The number of times of automatic retry receiving before receiving error is generated. This bit can be set only when USART is not enabled.
21:20	WSIFLGSEL	R/W	Wakeup From Stop Mode Interrupt Flag Select 00: Address matches 01: Reserved 10: When start bit is detected 11: When the receive data register is not empty This bit can be set only when USART is not enabled.
22	WSMIEN	R/W	Wakeup from Stop mode interrupt enable 0: Disable 1: Generate an interrupt when WSMFLG is set Set or cleared by software.
31:23	Reserved		

22.6.4 Baud rate register (USART_BR)

This register can be set only when USART is not enabled. This bit may be reset by hardware during automatic baud rate detection.

Offset address: 0x0C

Reset value: 0x0000

Field	Name	R/W	Description
3:0	FBR	R/W	Fraction of USART Baud Rate Divider factor The decimal part of USART baud rate division factor is determined by these four bits.
15:4	IBR	R/W	Integer of USART Baud Rate Divider factor The integral part of USART baud rate division factor is determined by these 12 bits.
31:16	Reserved		

22.6.5 Protection time and prescaler register (USART_GTPSC)

Offset address: 0x10

Reset value: 0x0000

Field	Name	R/W	Description
7:0	PSC	R/W	<p>Prescaler Factor Setup</p> <p>Divide the frequency and provide clock for the system clock respectively; in different working modes, the valid bits of PSC have difference, specifically as follows:</p> <p>In infrared low-power mode:</p> <p>PSC[7:0] is valid.</p> <p>00000000: Reserved</p> <p>00000001: 1 divided frequency</p> <p>00000010: 2 divided frequency</p> <p>.....</p> <p>11111111: 255 divided frequency</p> <p>In infrared normal mode:</p> <p>PSC can only be set to 00000001</p> <p>In smart card mode:</p> <p>PSC[7:5] invalid, PSC[4:0] valid</p> <p>00000: Reserved</p> <p>00001: 2 divided frequency</p> <p>00010: 4 divided frequency</p> <p>00011: 6 divided frequency</p> <p>.....</p> <p>11111: 62 divided frequency</p> <p>The bit [7:5] is not used in smart card mode.</p> <p>This bit can be set only when USART is not enabled.</p>
15:8	GRDT	R/W	<p>Guard Time Value Setup</p> <p>After transmitting data, TXCFLG can be set only after the protection time; the time unit is baud clock; which can be applied to smart card mode.</p> <p>This bit can be set only when USART is not enabled.</p>
31:16	Reserved		

22.6.6 Receive timeout register (USART_RXTO)

Offset address: 0x14

Reset value: 0x0000

Field	Name	R/W	Description
23:0	RXTO	R/W	<p>Receiver Timeout Value Setup</p> <p>This bit field specifies the receive timeout value in baud clock.</p> <p>In standard mode, after the last byte is received, if no new start bit is detected within the duration of RXTO value, RXTOFLG will be set by hardware.</p> <p>In smart card mode, this value is used to realize CWT and BWT. In this mode, start timeout measurement from the start bit of the last byte.</p>
31:24	BLLEN[7:0]	R/W	<p>Block Length Setup</p> <p>This bit field specifies the block length when receiving the smart card mode T=1. This value is the number of characters in the information block + the end part (1-LEC/2-CRC)-1.</p> <p>For example:</p> <p>BLLEN =0->0 information characters +LEC</p> <p>BLLEN =1->0 information characters +CRC</p> <p>BLLEN =255-> 254 information characters +CRC</p> <p>In smart card mode, when TXBEFLG=0, the block length counter will be cleared.</p> <p>The block length counter is cleared when RXEN=0 or EOBCFLG bit is set.</p>

22.6.7 Request register (USART_REQUEST)

Offset address: 0x18

Reset value: 0x0000

Field	Name	R/W	Description
0	ABRDQ	W	<p>Auto Baud Rate Detection Request</p> <p>Set this bit, the ABRDFLG flag will be cleared and an automatic baud rate detection will be conducted when the data is received next time.</p>
1	TXBFQ	W	<p>Transmit Break Frame Request</p> <p>Set this bit, TXBFFLG flag will be set and a break frame will be transmitted after the transmission state machine is enabled.</p>
2	MUTEQ	W	<p>Mute Mode Request</p> <p>Set this bit to enter the mute mode and RXWFMUTE flag will be cleared.</p>
3	RXDFQ	W	<p>Receive Data Flush Request</p> <p>Set this bit and RXBNEFLG flag will be cleared.</p> <p>The data that has not been read out in the receive register can be discarded to avoid overrun error</p>
4	TXDFQ	W	<p>Transmit Data Flush Request</p> <p>Set this bit and TX flag will be set.</p> <p>Data transmission can be canceled. This bit takes effect when data are not transmitted due to error interrupt and FEFLG flag is set.</p> <p>This bit takes effect only in smart card mode</p>
31:5	Reserved		

22.6.8 Interrupt and state register (USART_STS)

Offset address: 0x1C

Reset value: 0x0200 00C0

Field	Name	R/W	Description
-------	------	-----	-------------

Field	Name	R/W	Description
0	PEFLG	R	Parity Error Occur Flag 0: No error 1: Parity error is detected In receiving mode, when a parity error occurs, it is set to 1 by hardware; set PECLR and this bit can be cleared.
1	FEFLG	R	Frame Error Occur Flag 0: No frame error 1: Frame error or disconnection symbol is detected When there is synchronous dislocation, too much noise or disconnection symbol, this bit is set to 1 by hardware; set FECLR and this bit can be cleared.
2	NEFLG	R	Noise Error Occur Flag 0: No noise 1: Noise is detected When there is noise error, this bit is set to 1 by hardware; set NFCLR and this bit can be cleared.
3	OVREFLG	R	Overrun Error Occur Flag 0: No overrun error 1: Overrun error is detected When the RXBNEFLG bit is set and the data in the shift register is to be transmitted to the receive register, set to 1 by hardware; set OVRECLR and this bit can be cleared.
4	IDLEFLG	R	IDLE Line Detected Flag 0: Idle bus is not detected 1: Idle bus is detected When idle bus is detected, this bit is set to 1 by hardware; this bit can be cleared by setting IDLECLR.
5	RXBNEFLG	R	Receive Data Buffer Not Empty Flag 0: The receive data buffer is empty 1: The receive data buffer is not empty When the data register receives the data transmitted by the receive shift register, it is set to 1 by hardware; this bit can be cleared by reading the TXDATA register or setting RXDFQ.
6	TXCFLG	R	Transmit Data Complete Flag 0: Transmitting data is not completed 1: Transmitting data is completed After the last frame of data is transmitted and the TXBEFLG is set, set to 1 by hardware; conduct write operation to TXDATA register or set TXCCLR and this bit can be cleared.
7	TXBEFLG	R	Transmit Data Buffer Empty Flag 0: The transmit data buffer is not empty 1: The transmit data buffer is empty When the shift register receives the data transmitted by the transmit data register, this bit is set to 1 by hardware; this bit can be cleared by performing write operation on TXDATA register.
8	LBDFLG	R	LIN Break Detected Flag 0: LIN disconnection not detected 1: LIN disconnection detected When LIN disconnection is detected, this bit is set to 1 by hardware; this bit can be cleared by setting LBDCLR. If LBDIEN in USART_CTRL2 is set, an interrupt will be generated.
9	CTSFLG	R	CTS Change Flag 0: No change on nCTS state line 1: There is change on nCTS state line If the CTSEN bit is set, when switching to the nCTS input, set to 1 by hardware; this bit can be cleared by setting CTSCCLR.
10	CTSCFG	R	CTS Status Configure 0: Set nCTS line 1: Reset nCTS line This bit is set to 1 or cleared by hardware.

Field	Name	R/W	Description
			This bit sets reversed state of nCTS input pin.
11	RXTOFLG	R	Receiver Timeout Flag 0: No timeout 1: Timed out If the start bit is not detected within the duration set by RXTO bit, this bit is set to 1 by hardware; this bit can be cleared by setting RXTOCLR bit.
12	EOBFLG	R	End of Block Flag 0: Fail to reach the end of block 1: Reach the end of block When receiving a complete block, this bit is set to 1 by hardware; this bit can be cleared by setting EOBCLR bit. Detection is completed when the received bytes are BLEN+4. If EOBIEN bit is set, an interrupt will be generated.
13	Reserved		
14	ABRDEFLG	R	Auto Baud Rate Detection Error Flag This bit is set to 1 by hardware when baud rate detection fails; this bit can be cleared by setting ABRDQ bit.
15	ABRDFLG	R	Auto Baud Rate Detection Flag When the automatic baud rate function is turned on or when the automatic baud rate operation is interrupted, it is set to 1 by hardware; this bit is cleared when resuming the baud rate detection.
16	BSYFLG	R	Busy Flag 0: Idle state 1: In the process of receiving data This bit is set to 1 by hardware when the start bit is detected, and it will be cleared after receiving is over. This bit is set to 1 or cleared by hardware.
17	CMFLG	R	Character Match Flag 0: No character matches 1: There is matching character When the received character matches the value set by ADDR[7:0], this bit is set to 1 by hardware; this bit can be cleared by setting CMCLR bit.
18	TXBFFLG	R	Transmit Break Frame Flag 0: Not transmit 1: Will transmit If TXBFQ bit is set, this bit can be set to 1 by software; when transmitting the stop bit of the break frame, this bit is cleared by hardware.
19	RXWFMUTE	R	Receiver Wakeup From Mute Mode 0: Normal mode 1: Mute mode When switching the wake-up mode and the mute mode, this bit shall be set to 1 and cleared by hardware; if it is waken up by idle signal, this bit can be set to 1 by writing to USART_REQUEST register. WUPMCFG bit determines the control sequence of mute mode.
20	WSMFLG	R	Wakeup From Stop Mode Flag 0: Not detected 1: Detected This bit can be cleared by setting PECLR bit. If WSMFLG bit is set, an interrupt will be generated.
21	TXENACKFLG	R	Transmit Enable Acknowledge Flag Set to 1 by hardware when reading the transmit enable signal. The idle frame request will be generated when TXEN=0. To ensure minimum cycle of TXEN=0, TXEN will be set immediately.
22	RXENACKFLG	R	Receive Enable Acknowledge Flag Set to 1 by hardware when reading the receive enable signal. This bit is used to confirm whether USART has been ready to receive data before entering the stop mode.

Field	Name	R/W	Description
31:23			Reserved

22.6.9 Interrupt flag clear register (USART_INTFCLR)

Offset address: 0x20

Reset value: 0x0000

Field	Name	R/W	Description
0	PECLR	RC_W1	Parity Error Flag Clear Set this bit and PEFLG flag bit of USART_STS register can be cleared.
1	FECLR	RC_W1	Framing Error Flag Clear Set this bit and FEFLG flag bit of USART_STS register can be cleared.
2	NECLR	RC_W1	Noise Detected Flag Clear Set this bit and NEFLG flag bit of USART_STS register can be cleared.
3	OVRECLR	RC_W1	Overrun Error Flag Clear Set this bit and OVREFLG flag bit of USART_STS register can be cleared.
4	IDLECLR	RC_W1	IDLE Line Detected Clear Flag Set this bit and IDLEFLG flag bit of USART_STS register can be cleared.
5			Reserved
6	TXCCLR	RC_W1	Transmission Data Complete Flag Clear Set this bit and TXCFLG flag bit of USART_STS register can be cleared.
7			Reserved
8	LBDCLR	RC_W1	LIN Break Detection Flag Clear LBDFLG flag bit of USART_STS register can be cleared by setting this bit.
9	CTSCLR	RC_W1	CTS Flag Clear Set this bit and CTSFLG flag bit of USART_STS register can be cleared.
10			Reserved
11	RXTOCLR	RC_W1	Receiver Timeout Flag Clear Set this bit and RXTOFLG flag bit of USART_STS register can be cleared.
12	EOBCLR	RC_W1	End of Block Flag Clear EOBFLG flag bit of USART_STS register can be cleared by setting this bit.
16:13			Reserved
17	CMCLR	RC_W1	Character Match Flag Clear Set this bit and CMFLG flag bit of USART_STS register can be cleared.
19:18			Reserved
20	WSMCLR	RC_W1	Wakeup From Stop Mode Flag Clear WSMFLG flag bit of USART_STS register can be cleared by setting

Field	Name	R/W	Description
			this bit.
31:21	Reserved		

22.6.10 Receive data register (USART_RXDATA)

Offset address: 0x24

Reset value: 0xFFFF

Field	Name	R/W	Description
8:0	RXDATA	R	Receive Data Value Setup Include the received data byte. Provide the parallel interface between input shift register and internal bus. If the check bit is turned on when receiving data, read this register and the most significant bit is the check bit.
31:9	Reserved		

22.6.11 Transmit data register (USART_TXDATA)

Offset address: 0x28

Reset value: 0xFFFF

Field	Name	R/W	Description
8:0	TXDATA	R/W	Transmit Data Value Setup Include the data byte to be transmitted. Provide the parallel interface between transmit shift register and internal bus. If the check bit is turned on when transmitting data, it is invalid to write to the most significant bit, and it will be replaced by the check bit and transmitted again.
31:9	Reserved		

23 Internal Integrated Circuit Interface (I2C)

23.1 Full Name and Abbreviation Description of Terms

Table 72 Full Name and Abbreviation Description of Terms

Full name in English	English abbreviation
Serial Data	SDA
Serial Clock	SCL
System Management Bus	SMBus
Clock	CLK
Serial Clock High	SCLH
Serial Clock Low	SCLL
Address Resolution Protocol	ARP
Negative Acknowledgement	NACK
Acknowledgement	ACK
Packet Error Checking	PEC

23.2 Introduction

I2C is a short-distance bus communication protocol. In physical implementation, I2C bus is composed of two signal lines (SDA and SCL) and a ground wire. These two signal lines can be used for bidirectional transmission.

- Two signal lines, SCL clock line and SDA data line. SCL provides timing for SDA, and SDA transmits/receives data in series
- Both SCL and SDA signal lines are bidirectional
- The ground is common when the two systems use I2C bus for communication

23.3 Main Characteristics

- (1) Can select master or slave mode
- (2) Multi-master function
- (3) 7-bit and 10-bit addressing mode
- (4) Response to broadcast
- (5) Multiple 7-bit slave address
- (6) Three modes
 - Standard mode
 - Fast mode
 - Fast mode plus

Figure 106 I2C2 Function Structure Diagram

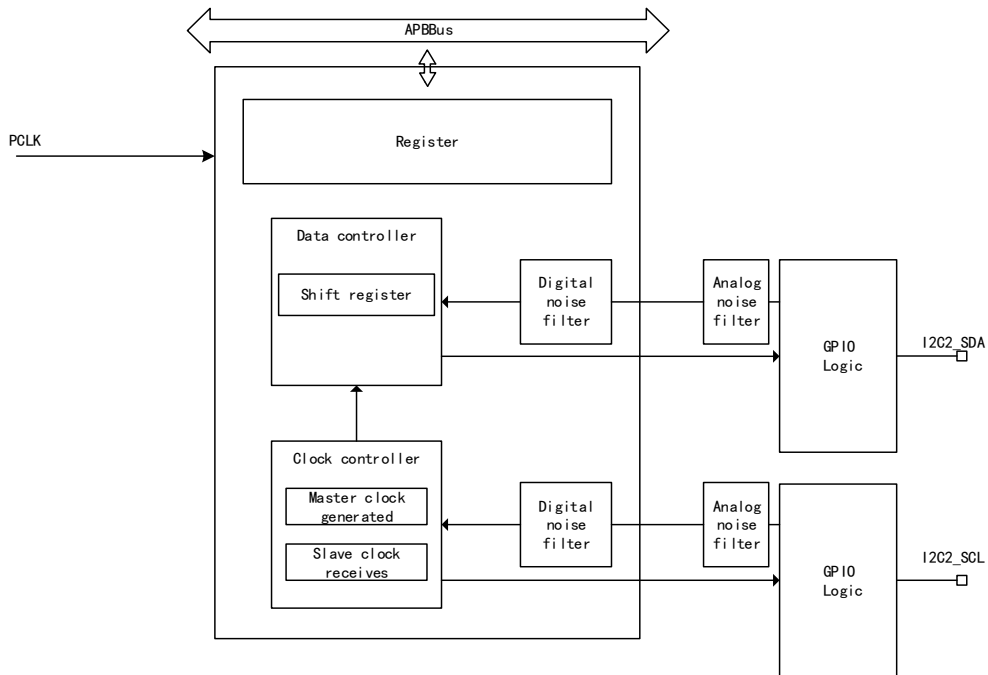

23.5 Functional Description

23.5.1 I2C Physical Layer

Figure 107 Commonly Used I2C Communication Connection Diagram

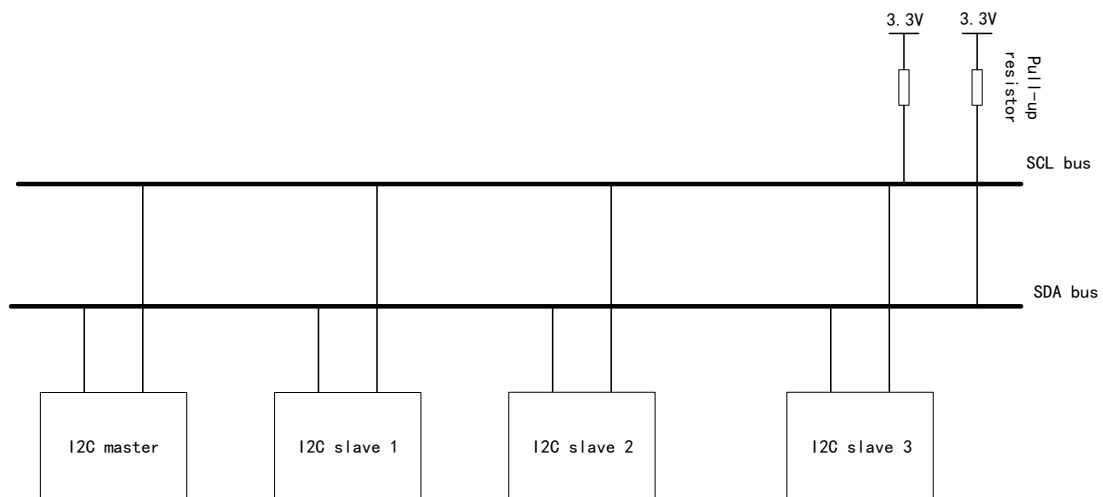

Characteristics of physical layer

- (1) Bus supporting multiple devices (signal line shared by multiple devices), which, in I2C communication bus, can connect multiple communication masters and communication slaves.

- (2) An I2C bus only uses two bus lines, namely, a bidirectional serial data line (SDA) and a serial clock line (SCL). The data line is used for data transmission, and the clock line is used for synchronous receiving and transmission of data.
- (3) Each device connected to the bus has an independent address (seven or ten bits), and the master addresses and accesses the slave device according to the address of the device.
- (4) The bus needs to connect the pull-up resistor to the power supply. When I2C bus is idle, the output is in high-impedance state. When all devices are idle, the output is in high-impedance state, and the pull-up resistor pulls the bus to high level.
- (5) Three communication modes: Standard mode (up to 100KHz), fast mode (up to 400KHz), and fast mode plus (up to 1MHz).
- (6) When multiple masters use the bus at the same time, to prevent the data conflict, the bus arbitration mode is adopted to determine which device occupies the bus.
- (7) Can program setup and hold time, and program the high-level time and low-level time of SCL in I2C.

23.5.2 I2C Protocol Layer

Characteristics of protocol layer

- (1) Data is transmitted in the form of frame, and each frame is composed of 1 byte (8 bits).
- (2) In the rising edge phase of SCL, SDA needs to keep stable and SDA changes during the period when SCL is low.
- (3) In addition to data frame, I2C bus also has start bit, stop bit and acknowledge bit.
 - Start bit: During the stable high level period of SCL, a falling edge of SDA starts transmission.
 - Stop bit: During the stable high level period of SCL, a rising edge of SDA stops transmission.
 - Acknowledge bit: Used to indicate successful transmission of one byte. After the bus transmitter (regardless of the master or slave) transmits 8-bit data, SDA will release (from output to input). During the ninth clock pulse, the receiver will pull down SDA to respond to the received data.

I2C communication reading and writing process

Figure 108 Master Writes Data to Slave

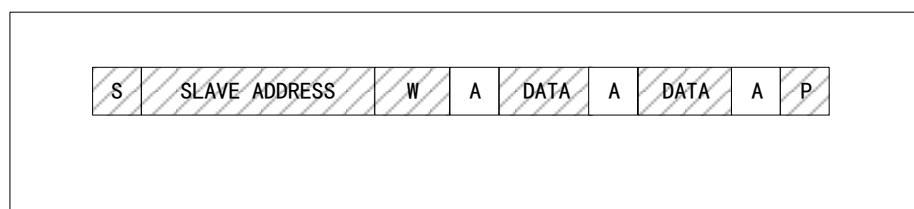
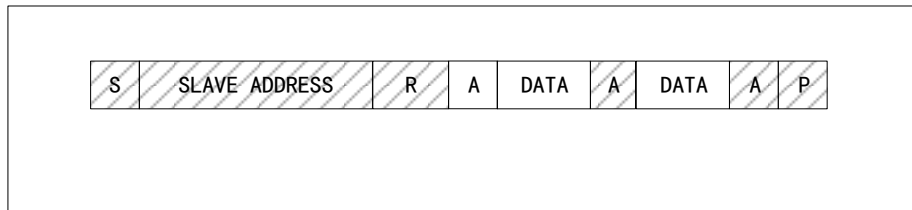



Figure 109 Master Reads Data from Slave



Note:

- (1) : This data is transferred from master to slave
- (2) S: Start signal
- (3) SLAVE ADDRESS: Slave address
- (4) : This data is transferred from slave to master
- (5) R/W: Selection bit of transmission direction
- (6) 1 means reading, while 0 means writing
- (7) P: Stop signal

After the start signal is generated, all slaves will wait for the slave address signal transmitted by the master. In I2C bus, the address of each device is unique. When the address signal matches the device address, the slave will be selected, and the unselected slave will ignore the future data signal.

When the transmission direction is writing data

After broadcasting the address and receiving the acknowledge signal, the master will transmit data to the slave. The length of the data is one byte. Every time the master transmits one byte of data, it needs to wait for the acknowledge signal transmitted by the slave. When all the bytes are transmitted, the master transmits a stop signal to the slave, indicating that the transmission is completed.

When the transmission direction is reading data

After broadcasting the address and receiving the acknowledge signal, the slave will transmit the data to the master. The size of the data package is 8 bits. Every time the master transmits one byte of data, it needs to wait for the acknowledge signal of the slave. When the master wants to stop receiving data, it needs to return a non-answer signal to the slave, then the slave will stop transmitting the data automatically.

23.5.3 Introduction to I2C Clock

23.5.3.1 I2C clock source

I2C is driven by an independent clock source, and it can make I2C1 operate independent of PCLK frequency.

I2C clock source can select HSICLK or SYSCLK.

23.5.3.2 Requirements for I2C clock

- (1) $t_{I2C_CLK} < (t_{low} - t_{filters})/4$ and $t_{I2C_CLK} < t_{HIGH}$
- (2) t_{low} : SCL low-level time
- (3) t_{HIGH} : SCL high-level time
- (4) $t_{filters}$: Total lag caused by analog filter and digital filter when I2C is started

I2C clock configuration

Before peripherals are started, it is required to configure SCLH and SCLL bits in I2C_TIMING register to configure the I2C clock.

It can realize clock synchronization mechanism and support multiple master environments and slave clock extension.

$$t_{SCL} = t_{SYNC1} + t_{SYNC2} + \{ ((SCLH+1) + (SCLL+1)) * (TIMINGPSC+1) * t_{I2C_CLK} \}$$

t_{SYNC1} depends on:

- SCL descending slope
- Input delay of analog filter
- Input delay of digital filter
- Delay caused by synchronous I2C_CLK clock of SCL

t_{SYNC2} depends on:

- SCL rising slope:
- Input delay of analog filter
- Input delay of digital filter
- Delay caused by synchronous I2C_CLK clock of SCL

To make I2C compatible with SMBus mode, the requirements for clock timing are shown in the table below:

Table 73 Clock Timing Requirements

Symbol	Parameter	Standard mode		Fast mode		Fast mode plus		SMBus		Unit
		Minimum value	Maximum value	Minimum value	Maximum value	Minimum value	Maximum value	Minimum value	Maximum value	
f_{SCL}	SCL clock frequency	-	100	-	400	-	1000	-	100	KHz
$t_{HD:STA}$	START signal hold time	4	-	0.6	-	0.26	-	4.0	-	μ s
$t_{SU:STA}$	START signal setup time	5	-	0.6	-	0.26	-	4.7	-	μ s
$t_{SU:STO}$	STOP signal setup time	4	-	0.6	-	0.26	-	4.7	-	μ s
t_{BUF}	Idle time of bus between STOP and START signals	5	-	1.3	-	0.50	-	4.0	-	μ s
t_{LOW}	SCL clock low-level time	8	-	1.3	-	0.50	-	4.7	-	μ s
t_{HIGH}	SCL clock high-level time	4	-	0.6	-	0.26	-	4.0	50	μ s
t_r	Rising edge time of SDA and SCL signals	-	1000	-	300	-	120	-	1000	ns

Symbol	Parameter	Standard mode		Fast mode		Fast mode plus		SMBus		Unit
t_f	Falling edge time of SDA and SCL signals	-	300	-	300	--	120	-	300	ns

23.5.3.3 I2C_TIMING register configuration

Table 74 I2C_TIMING Register Configuration

$f_{I2C_CLK}=48MHz$				
Parameter	Standard mode		Fast mode	Fast mode plus
	10 KHz	100 KHz	400 KHz	1 MHz
TIMINGPSC	0xB	0xB	5	5
SCLL	0xC7	0x13	0x9	0x3
t_{SCLL}	$200 \times 250ns = 50\mu s$	$20 \times 250ns = 5.0\mu s$	$10 \times 125ns = 1250 ns$	$4 \times 125 ns = 500 ns$
SCLH	0xC3	0xF	0x3	0x1
t_{SCLH}	$196 \times 250 ns = 49\mu s$	$16 \times 250 ns = 4.0\mu s$	$4 \times 125 ns = 500 ns$	$2 \times 125 ns = 250 ns$
t_{SCL}	100 μs	10 μs	2500ns	875ns
DATAHT	0x2	0x2	0x3	0
t_{DATAHT}	$2 \times 250 ns = 500 ns$	$2 \times 250 ns = 500 ns$	$3 \times 125 ns = 375 ns$	0ns
DATAT	0x4	0x4	0x3	0x1
t_{DATAT}	$5 \times 250 ns = 1250 ns$	$5 \times 250 ns = 1250 ns$	$4 \times 125 ns = 500 ns$	$2 \times 125 ns = 250 ns$

Note:

$$t_{I2C_CLK} = 1 / f_{I2C_CLK}$$

$$t_{TIMINGPSC} = (TIMINGPSC + 1) \times t_{I2C_CLK}$$

$$t_{DATAT} = (DATAT + 1) \times t_{TIMINGPSC}$$

$$t_{DATAHT} = DATAHT \times t_{TIMINGPSC}$$

$$t_{SCLH} = (SCLH + 1) \times t_{TIMINGPSC}$$

$$t_{SCLL} = (SCLL + 1) \times t_{TIMINGPSC}$$

23.5.4 I2C Function Configuration Mode

The interface can be configured to the following modes:

- Slave transmitting
- Slave receiving
- Master transmitting
- Master receiving

In the initial state of I2C interface, the working mode is slave mode. After I2C interface transmits the start signal, it will automatically switch from slave mode to master mode.

23.5.4.1 Slave mode

Transmit in slave mode

After the master transmits the start signal and address, the addressing is successful, the ADDR_MFLG bit is cleared, and the transmitter will transmit the data to be transmitted from I2C_TXDATA register to SDA line by internal shift register.

Every time the slave transmits a byte, it will wait for the master's acknowledge signal (ACK) and repeat this process until the master wants to stop receiving data and returns a non-acknowledge signal (NACK) to the slave. At this time, the slave will stop data transmission.

Receive in slave mode

After receiving the address of the master, ADDR_MFLG bit will be cleared, and the data received by the slave from the SDA line through the internal shift register are stored in I2C_RXDATA register.

After the slave receives a byte, it will transmit an acknowledge signal (ACK) to the master and when the master transmits a stop signal, the transmission is over.

Extension of slave clock

In default mode, I2C slave will pull down SCL clock in the following situations:

- The received address matches the enabled slave address, and SCL clock is pulled down and will be released when ADDR_MFLG flag is cleared by software. ADDR_MFLG flag bit can be cleared by setting ADDR_MCLR bit to 1.
- When transmitting, if the previous data have been transmitted and no new data are written to I2C_TXDATA register, or ADDR_MFLG flag is cleared, and no byte is written to I2C_TXDATA register, the SCL clock will be pulled down and when data are written to I2C_TXDATA register, the SCL clock will be released.
- When receiving, if the content of I2C_RXDATA register is not read and new data are received, the SCL clock will be pulled down and when I2C_RXDATA register is read, the SCL clock will be released.

23.5.4.2 Master mode

Master transmitting

I2C interface transmits the start signal and transmits the address to the SDA line through the internal shift register. The transmission direction is write, waiting for the slave to respond. After the slave responds, the master will transmit bytes from I2C_TXDATA register to SDA line through the internal shift register and wait for the acknowledge signal (ACK) transmitted by slave, and so forth. When

I2C_TXDATA register writes the last byte, the stop bit is set to generate a stop signal.

Master receiving

The I2C interface transmits the start signal and transmits the address to the SDA line through the internal shift register. The transmission direction is read. After the slave responds, the master enters the receiving mode, receives the data on the SDA line through the internal shift register and transmits them to I2C_RXDATA register. Every time the master receives a data, it will return an acknowledge signal (ACK). This process will be repeated and when the master needs to stop reading data, it will transmit a non-acknowledge signal (NACK) to stop reading data.

23.5.4.3 SMBus specific function

The system management bus (SMBus) is a two-wire interface, which is based on I2C bus principle.

The system management bus specification refers to three types of devices

Slave: Device of receiving or corresponding command.

Master: Device that issues commands, generates clocks and terminates transmission.

HOST: A special master, which provides interfaces to system CPU. The HOST must have dual functions of master and slave, and support SMBus HOST notification protocol, and one system has only one HOST.

Bus protocol

There are 11 possible command protocols for any given device, and one device can communicate with any or all of 11 protocols.

Address resolution protocol (ARP)

SMBus slave address conflict can be solved by calibrating a new unique address for the slave device. In order to assign addresses, a mechanism is needed to distinguish each device, and each device has a unique device identifier. The 128-bit identifier is implemented by software.

This device supports address resolution protocol (ARP). Set DEADDREN bit in I2C_CTRL1 register to 1, and the default address of SMBus device (0b1100001) will be enabled. ARP command is implemented by user software.

The arbitration supported by ARP is also completed in slave mode.

Command receiving and data acknowledgment control

SMBus receiver will return NACK to each command and data received. Start the ACK control in slave mode, and set SBCEN bit of I2C_CTRL1 register to 1 to start the slave byte control mode.

HOST notification protocol

Set HADDREN bit of I2C_CTRL1 register to make this peripheral support HOST notification protocol. In such case, HOST will acknowledge SMBus host slave (0b0001000).

Use this protocol, this device is used as the master, and HOST is used as the slave.

SMBus alarm

This peripheral can be supported by SMBus alert signal. When a device that is used only as the slave wants to initiate communication, it can notify HOST through SMBALERT pin. HOST will handle the interrupt and then access all SMBALERT devices through the alert response address (0b0001100). Only the device with the SMBALERT pin pulled down will respond to the alert response address.

SMBus timeout management

Table 75 SMBus Timeout Specification

Symbol	Parameter	Range		Unit
		Minimum value	Maximum value	
t_{TIMEOUT}	Low timeout of detection clock	25	35	ms
$t_{\text{LOW:SEXT}}$	Low extension time of cumulative clock of slave		25	ms
$t_{\text{LOW:MEXT}}$	Low extension time of cumulative clock of master		10	ms

$t_{\text{LOW:SEXT}}$ is an extensible clock cycle accumulation given by a slave device from START to STOP. When a slave device or a master device occupies the clock, the total low clock time is greater than $t_{\text{LOW:SEXT}}$. Therefore, the test condition of this parameter is that the slave is the only communication target of a full-speed master.

$t_{\text{LOW:MEXT}}$ is the clock cycle accumulation allowed by a master device to transmit a byte in the way of from START to ACK, from ACK to ACK, from ACK to STOP. When another slave device or master occupies the clock, the total time occupies by the clock may also be greater than $t_{\text{LOW:MEXT}}$. Therefore, the measurement condition of this parameter is that only one full-speed slave is the only communication target.

Figure 110 $t_{\text{LOW:SEXT}}$ and $t_{\text{LOW:MEXT}}$ Time

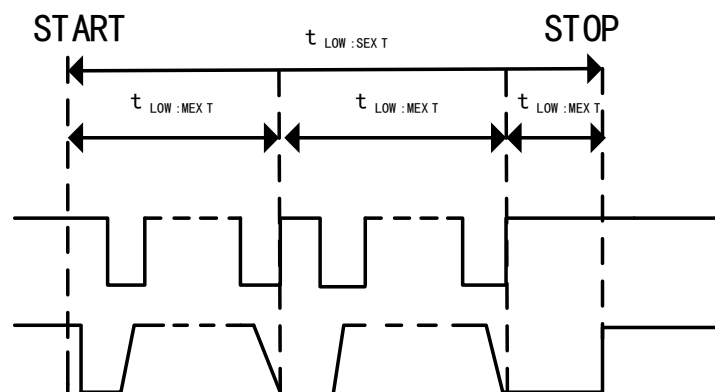

Idle bus detection

If the master detects that the clock signal is high time greater than $t_{\text{HIGH,MAX}}$, the bus is in idle state.

23.5.4.4 Wake up from the stop mode

When WUPEN bit of I2C_CTRL1 register is set to 1, enable the function of wake-up from stop mode.

It can wake up from the stop mode only when HSICLK oscillator is selected as the clock source of I2C_CLK.

In stop mode, HSICLK is in closed state; after the start bit is detected, I2C interface will turn on HSICLK and SCL is pulled down until HSICLK is started. When the address matches, I2C will pull down SCL continuously during MCU wake-up period. SCL can be released only when ADDRMLFG flag is cleared by software, and then the transmission will enter normal state. If the address does not match, HSICLK will be closed, and MCU will remain in stop mode.

Note:

- (1) If I2C_CLK is selected as system clock or WUPEN=0, HSICLK oscillate will not be turned on even if it receives the start bit.
- (2) MCU can be woken up only by ADDR interrupt, and when I2C is used as the master to transmit data or the slave is addressed, it is not allowed to enter the stop mode.
- (3) The digital filter and wake-up in stop mode are not compatible. Therefore, if DNFCFG bit is not 0, setting WUPEN bit is ineffective.
- (4) Clock extension function needs to be enabled.

23.5.4.5 Error flag bit

I2C communication has the following error flag bits that may cause communication failure.

Bus error flag bit (BERRFLG)

When a START or STOP condition is detected outside 9 times of SCL clock pulse signal, a bus error will occur. When SCL is high and a rising or falling edge occurs on SDA, it will be detected as START or STOP signal.

Only when I2C is communicating and transmitting data, can bus error occur (after data have been transmitted as the master or the address has matched as the slave). This error will not occur in slave mode address matching phase.

When a bus error is detected, BERRFLG flag bit of I2C_STS register will be set to 1 by hardware; if ERRIEN bit of I2C_CTRL1 register is set to 1, an error interrupt will be generated.

Arbitration loss flag bit (ALFLG)

When a high level is transmitted on the SDA line, but the rising edge of SCL samples a low level from SDA, it will be detected as an arbitration loss error.

- In master mode, arbitration loss is detected in address phase, data phase and data validation phase. In such case, SDA and SCL lines will be released, the START control bit will be cleared by hardware, and the master mode is automatically switched to slave mode.
- In slave mode, arbitration loss is detected in data phase and data validation phase. In this case, transmission is terminated and SCL and SDA lines are released.

When an arbitration loss error is detected, ALFLG flag bit of I2C_STS register will be set to 1 by hardware; if ERRIEN bit of I2C_CTRL1 register is set to 1, an error interrupt will be generated.

Overrun/Underrun error flag bit (OVRURFLG)

When clock extension is disabled, underrun or overrun error will be detected

under the following conditions in slave mode:

- When receiving, the RXDATA register has not been read, but the newly transmitted byte has been received.
- When transmitting, the first data byte should be transmitted, but STOPFLG=1. If TXBEFLG=0, the value of I2C_TXDATA register is transmitted; if it is not 0, then 0xFF is transmitted.
- When transmitting, if a new byte should be written to I2C_TXDATA register, but it is not written, 0xFF will be transmitted.

When an overrun/underrun error is detected, OVRURFLG flag of I2C_STS register will be set to 1 by hardware; if ERRIEN bit of I2C_CTRL1 register is set to 1, an interrupt will be generated.

Packet error check error flag bit (PECEFLG)

This error condition is only for SMBus function part. After receiving PEC byte not matching the content of I2C_PEC register, PEC error will be detected. After the error PEC is received, a NACK will be returned automatically. When PEC error is detected, PECEFLG flag of I2C_STS register will be set to 1 by hardware; if ERRIEN bit of I2C_CTRL1 register is set to 1, an interrupt will be generated.

Timeout error flag bit (TTEFLG)

This error condition is only for SMBus function part.

Timeout error will occur under the following conditions:

- (1) SMBus timeout is detected
 - IDLECLKTO=0 and the low time maintained by SCL reaches the time defined by TIMEOUTA[11:0] bit field
 - IDLECLKTO=1 and the high-level time of SDA and SCL exceeds the time defined by TIMEOUTA[11:0] bit field
- (2) SMBus idle timeout is detected
 - The accumulative time of low extension of master clock reaches the time ($t_{LOW:MEXT}$) defined by TIMEOUTB[11:0] bit field
 - The accumulative time of low extension of slave clock reaches the time ($t_{LOW:SEXT}$) defined by TIMEOUTB[11:0] bit field

When a TIMEOUT error is detected, TTEFLG flag of I2C_STS register will be set to 1 by hardware; if ERRIEN bit of I2C_CTRL1 register is set to 1, an interrupt will be generated.

23.5.4.6 DMA request

DMA transmission can be enabled by setting DMATXEN bit of I2C_CTRL1 register. The data is put into the SRAM area set by DMA peripheral in advance and transmitted to I2C_TXDATA register (not needing to consider the state of TXINTFLG bit).

Only use DMA to transmit bytes:

- Master mode: Initialization, slave address, direction, byte number and start bit are set by software (when the slave address has been transmitted, DMA cannot be used for transmission). When all data are transmitted by DMA, DMA must be initialized before START bit is set to 1.
- Slave mode: DMA must be initialized before the address matching event.

23.5.5 I2C Interrupt

Table 76 Interrupt Request List

Interrupt event	Event flag bit	Method of clearing the event flag bit	Interrupt enable control bit
Received character is not empty	RXBNEFLG	Read I2C_RXDATA register	RXIEN
Transmit interrupt state	TXINTFLG	Write I2C_TXDATA register	TXIEN
Stop signal detection flag	STOPFLG	Write STOPCLR=1	STOPIEN
Transmission completion reload	TXCRFLG	Write I2C_CTRL2 and NUMBYT[7:0] is not 0	TXCIEN
Transmission completed	TXCFLG	Write START=1 or STOP=1	
Address match	ADDRMFLG	Write ADDRMCCLR=1	SADDRMIEN
Receive NACK flag bit	NACKFLG	Write NACKCLR=1	NACKRXIEN
Bus error	BERRFLG	Write BERRCLR=1	ERRIEN
Arbitration loss	ALFLG	Write ALCLR=1	
Overrun/Underrun error	OVRURFLG	Write OVRURCLR=1	
PEC error	PECEFLG	Write PECECLR=1	
Clock timeout	TTEFLG	Write TTECLR=1	
SMBus alert	SMBALFLG	Write SMBALTCLR=1	

To enable I2C interrupt, it is required to:

- Configure and start I2C channel in NVIC
- Configure I2C interrupt enable bit

23.6 Register Address Mapping

Table 77 I2C Register Address Mapping

Register name	Description	Offset address
I2C_CTRL1	Control register 1	0x00
I2C_CTRL2	Control register 2	0x04
I2C_ADDR1	Master address register 1	0x08
I2C_ADDR2	Master address register 2	0x0C
I2C_TIMING	Timing register	0x10
I2C_TIMEOUT	Timeout register	0x14
I2C_STS	State register	0x18
I2C_INTFCLR	Interrupt flag clear register	0x1C
I2C_PEC	PEC register	0x20
I2C_RXDATA	Receive data register	0x24
I2C_TXDATA	Transmit data register	0x28

23.7 Register Functional Description

23.7.1 Control register 1 (I2C_CTRL1)

Offset address: 0x00

Reset value: 0x0000 0000

Field	Name	R/W	Description
0	I2CEN	R/W	I2C Enable 0: Disable 1: Enable
1	TXIEN	R/W	Transmit Interrupt Enable 0: Disable 1: Enable
2	RXIEN	R/W	RX Interrupt Enable 0: Disabled 1: Enabled
3	SADDRMIEN	R/W	Slave Address Match Interrupt Enable 0: Disable 1: Enable
4	NACKRXIEN	R/W	NACK Received Interrupt Enable 0: Disable 1: Enable
5	STOPIEN	R/W	STOP Detection Interrupt Enable 0: Disable 1: Enable
6	TXCIEN	R/W	Transmit Complete Interrupt Enable 0: Disable 1: Enable
7	ERRIEN	R/W	Error Interrupt Enable 0: Disable 1: When the position 1 of any of the following state register is enabled, the interrupt will be generated: SMBALTFLG, TTEFLG, PECEFLG, OVRURFLG, ALFLG, and STS1_BERRFLG
11:8	DNFCFG	R/W	Digital Noise Filter Configure The digital noise filters of SDA and SCL are configured by this bit field. The length of digital filter is DNFCFG[3:0]*t _{I2C_CLK} . 0000: Disable 0001: Enable; one t _{I2C_CLK} 1111: Enable; 15 t _{I2C_CLK} If the analog filter is enabled at the same time, the digital filter will be added to the analog filter; This bit can be set only when I2CEN is not set.
12	ANFD	R/W	Analog Noise Filter Disable 0: Enable 1: Disable This bit can be set only when I2CEN is not set.
13	Reserved		
14	DMATXEN	R/W	DMA Transmit Enable 0: Disable 1: Enable
15	DMARXEN	R/W	DMA Receive Enable 0: Disable 1: Enable

Field	Name	R/W	Description
16	SBCEN	R/W	Slave Byte Control Enable 0: Disable 1: Enable
17	CLKSTRETCHD	R/W	Slave Mode Clock Stretching Disable 0: Enable 1: Disable This bit can be set only when I2CEN is not set, and it is applicable only to the slave mode.
18	WUPEN	R/W	Wakeup From Stop Mode Enable 0: Disable 1: Enable
19	RBEN	R/W	Responds Broadcast Enable The address of response to broadcast is 0x00. 0: Disable 1: Enable
20	HADDREN	R/W	SMBus Host Address Enable The HOST address is 0x10/0x11. 0: Disable 1: Enable If SMBus mode is not supported, this bit will be reserved and be forced to 0.
21	DEADDREN	R/W	SMBus Device Default Address Enable The default address is 0xC2/0xC3. 0: Disable 1: Enable If SMBus mode is not supported, this bit will be reserved and be forced to 0.
22	ALTEN	R/W	SMBus Alert Function Enable Device mode (HADDREN=0): 0: Release SMBALERT pin and disable the notification response address header after NACK. 1: Pull down SMBALERT pin and enable the notification response address header after ACK. HOST mode (HADDREN=1): 0: Not supported 1: Supported If ALTEN=0, SMBALERT pin can be used as a GPIO; If SMBus mode is not supported, this bit will be reserved and be forced to 0.
23	PECEN	R/W	PEC Enable 0: Disable 1: Enable If SMBus mode is not supported, this bit will be reserved and be forced to 0.
31:24	Reserved		

23.7.2 Control register 2 (I2C_CTRL2)

Offset address: 0x04

Reset value: 0x0000 0000

Field	Name	R/W	Description
0	SADDR[0]	R/W	Slave Address Setup When the address mode is 7 bits, the bit is invalid; when the address mode is 10 bits, this bit is bit [0] of the address.

Field	Name	R/W	Description
7:1	SADDR[7:1]	R/W	Slave Address Setup bit[7:1]of slave address.
9:8	SADDR[9:8]	R/W	Slave Address Setup When the address mode is 7 bits, the bit is invalid; when the address mode is 10 bits, this bit is the bit[9:8] of the address.
10	TXDIR	R/W	Master Mode Transfer Direction Setup 0: Write transmission 1: Read transmission
11	SADDRLEN	R/W	Slave Address Length Configure 0: 7-bit addressing mode 1: 10-bit addressing mode
12	ADDR10	R/W	Master Transmit 10-Bit Address Header Configure 0: Transmit 10-bit slave address read sequence: start bit + 2-byte 10-bit write direction address + restart + the first 7 bits of 10-bit read direction address. 1: Transmit the first 7 bits of 10-bit slave address read sequence + read direction.
13	START	R/W	Start Bit Transmit This bit can be set to 1 and cleared by software; it can be cleared by hardware after the start bit and address sequence are transmitted, arbitration loss occurs, timeout error occurs or I2CEN bit is not set, or be cleared by setting ADDRMLR bit of I2C_INTFCLR register. In master mode: 0: Not transmit 1: Transmit repeatedly In slave mode: 0: Not transmit 1: Transmit when the bus is idle It is meaningless to write 0 to this bit; Setting RELOAD bit and this bit does not work.
14	STOP	R/W	Stop Bit Transmit This bit can be set to 1 and cleared by software; it can be cleared by hardware when transmitting the stop bit or when I2CEN bit is not set. In master mode: 0: Not transmit 1: Transmit It is meaningless to write 0 to this bit.
15	NACKEN	R/W	Transmit NACK Enable This bit can be set to 1 and cleared by software; it can be cleared by hardware after the stop bit and NACK are transmitted, the address match event is received or when I2CEN bit is not set. 0: Transmit ACK 1: Transmit NACK It is meaningless to write 0 to this bit, and it is applicable only to the slave ode. In master receiving mode, it will be automatically transmitted after the last byte is transmitted and between transmitting the stop bit or RESTART bit. In slave receiving mode, NACK will be transmitted automatically when overrun occurs. In this case, NACKEN bit does not work; After PEC check of hardware is enabled, the confirmation value of PEC still does not depend on the value of NACK bit.
23:16	NUMBYT	R/W	Number of Bytes Setup This bit determines the number of bytes to be transmitted. This bit is meaningless when it is in slave mode and SBCEN=0. This bit can be set only when START bit is not set.
24	RELOADEN	R/W	NUMBYT Reload Mode Enable It can be set to 1 and cleared by software.

Field	Name	R/W	Description
			0: Transmission is over after transmission of NUMBYT bytes 1: Reload NUMBYT after transmission of NUMBYT bytes. After transmission of NUMBYT bytes, TXCFLG flag bit will be set and SCL will be pulled down.
25	ENDCFG	R/W	End Mode Configure It can be set to 1 and cleared by software. 0: Software end mode: after transmission of NUMBYT data, TXCFLG flag bit will be set, and SCL will be pulled down. 1: Automatic end mode: after transmission of NUMBYT data, a stop bit will be transmitted automatically. This bit does not work when it is in slave mode or RELOADEN bit is set.
26	PEC	R/W	Transfer Packet Error Checking Byte Enable This bit can be set to 1 and cleared by software; it can be cleared by hardware after PEC transmission is completed, the stop bit is received, the address match event is received or when I2CEN bit is not set. 0: Disable 1: Enable It is meaningless to write 0 to this bit. Set RELOADEN bit or clear SBCEN bit in slave mode and this bit will not work; If SMBus mode is not supported, this bit will be reserved and be forced to 0.
31:27	Reserved		

23.7.3 Master address register 1 (I2C_ADDR1)

Offset address: 0x08

Reset value: 0x0000 0000

Field	Name	R/W	Description
0	ADDR1[0]	R/W	Master Address Setup When the address mode is 7 bits, the bit is invalid; when the address mode is 10 bits, this bit is bit [0] of the address.
7:1	ADDR1[7:1]	R/W	Master Address Setup Master address bit[7:1]
9:8	ADDR1[9:8]	R/W	Master Address Setup When the address mode is 7 bits, the bit is invalid; when the address mode is 10 bits, this bit is the bit[9:8] of the address.
10	ADDR1LEN	R/W	Master Address Length Configure 0: 7-bit addressing mode 1: 10-bit addressing mode
14:11	Reserved		
15	ADDR1EN	R/W	Master Address 1 Enable 0: Disable. Transmit NACK after the slave address ADDR is received 1: Enable. Transmit ACK after the slave address ADDR is received
31:16	Reserved		

23.7.4 Master address register 2 (I2C_ADDR2)

Offset address: 0x0C

Reset value: 0x0000 0000

Field	Name	R/W	Description
0	Reserved		
7:1	ADDR2[7:1]	R/W	Master Address Setup Master address bit[7:1]
10:8	ADDR2MSK	R/W	Masks Master Address 2 Select 000: No mask 001: Mask ADDR2[1], compared with ADDR2[7:2]. 010: Mask ADDR2[2:1], compared with ADDR2[7:3]. 011: Mask ADDR2[3:1], compared with ADDR2[7:4]. 100: Mask ADDR2[4:1], compared with ADDR2[7:5]. 101: Mask ADDR2[5:1], compared with ADDR2[7:6]. 110: Mask ADDR2[6:1], compared with ADDR2[7]. 111: Mask ADDR2[7:1], without comparison; all 7-bit addresses received will transmit ACK. This bit can be set only when ADDR2EN bit is not set; if ADDR2MSK is not 0, and the reserved I2C address does not response, matching is meaningless.
14:11	Reserved		
15	ADDR2EN	R/W	Master Address 2 Enable 0: Disable. Transmit NACK after the slave address ADDR2 is received. 1: Enable. Transmit ACK after receiving the slave address ADDR2.
31:16	Reserved		

23.7.5 Timing register (I2C_TIMING)

Offset address: 0x10

Reset value: 0x0000 0000

Field	Name	R/W	Description
7:0	SCLL	R/W	SCL Low Level Time Setup $t_{SCLL} = (SCLL + 1) \times t_{TIMINGPSC}$ SCLL determines t_{BUF} and $t_{SU:STA}$ timing.
15:8	SCLH	R/W	SCL High Level Time Setup $t_{SCLH} = (SCLH + 1) \times t_{TIMINGPSC}$ SCLH determines $t_{SU:STO}$ and $t_{HD:STA}$ timing.
19:16	DATAHT	R/W	Data Hold Time Setup This bit field determines the delay t_{DATAHT} between SCL falling edge and SDA edge in transmitting mode. $t_{DATAHT} = DATAHT \times t_{TIMINGPSC}$ DATAHT determines $t_{HD:DAT}$ timing.
23:20	DATAT	R/W	Data Time Setup This bit field determines the delay t_{DATAT} between SDA edge and SCL rising edge in transmitting mode. $t_{DATAT} = (DATAT + 1) \times t_{TIMINGPSC}$ t_{DATAT} determines $t_{SU:DAT}$ timing.
27:24	Reserved		
31:28	TIMINGPSC	R/W	Timing Prescaler Setup This bit field divides the frequency of I2C_CLK, and provides clock cycle $t_{TIMINGPSC}$ for data setup, hold time counter and SCL high and low-level counter. $t_{TIMINGPSC} = (TIMINGPSC + 1) \times t_{I2C_CLK}$

Note: This register can be set only when I2CEN bit is not set.

23.7.6 Timeout register (I2C_TIMEOUT)

Offset address: 0x14

Reset value: 0x0000 0000

Field	Name	R/W	Description
11:0	TIMEOUTA	R/W	Bus Timeout A Setup When IDLECLKTO=0, and SCL timeout is low: $t_{\text{TIMEOUT}} = (\text{TIMEOUTA} + 1) \times 2048 \times t_{\text{I2C_CLK}}$ When IDLECLKTO=1, and the bus is idle: $t_{\text{IDLE}} = (\text{TIMEOUTA} + 1) \times 4 \times t_{\text{I2C_CLK}}$ This bit can be set only when CLKTOEN bit is not set.
12	IDLECLKTO	R/W	Idle Clock Timeout Detection Configure 0: SCL low-level timeout is detected 1: SCL and SDA high-level timeout is detected (the bus is idle) This bit can be set only when CLKTOEN bit is not set.
14:13	Reserved		
15	CLKTOEN	R/W	Clock Timeout Enable 0: Disable 1: Enable. A timeout error is detected when the hold time of low SCL is more than t_{TIMEOUT} or the hold time of high SCL is more than t_{IDLE} .
27:16	TIMEOUTB	R/W	Bus Timeout B Setup The accumulated master clock low extension time to be detected in master mode ($t_{\text{LOW:MEXT}}$). The accumulated slave clock low extension time to be detected in slave mode ($t_{\text{LOW:SEXT}}$). $t_{\text{LOW:EXT}} = (\text{TIMEOUTB} + 1) \times 2048 \times t_{\text{I2C_CLK}}$ This bit field can be set only when EXCLKTOEN bit is not set.
30:28	Reserved		
31	EXCLKTOEN	R/W	Extended Clock Timeout Enable 0: Disable 1: Enable. A timeout error is detected when the hold time of low SCL reaches $t_{\text{LOW:EXT}}$.

23.7.7 State register (I2C_STS)

Offset address: 0x18

Reset value: 0x0000 0001

Field	Name	R/W	Description
0	TXBEFLG	R/S	Transmit Data Buffer Empty Flag 0: The transmit buffer is not empty 1: The transmit buffer is empty This bit is set to 1 by hardware when the content of I2C_TXDATA register is empty; this bit is cleared when the data to be transmitted are written to I2C_TXDATA register. This bit can be set to 1 by software to clear I2C_TXDATA register; when I2CEN=0, this bit is cleared by hardware.
1	TXINTFLG	R/S	Transmit Interrupt State Flag 0: Not transmit 1: Transmit This bit is set to 1 by hardware when I2C_TXDATA register is empty; then write the data to be transmitted to I2C_TXDATA register. This bit can be cleared by writing the data to be transmitted to I2C_TXDATA register. This bit can be set to 1 by software when CLKSTRETCHD=1, so as to generate TXINTFLG flag bit; it can be cleared by hardware when I2CEN=0.
2	RXBNEFLG	R	Receive Data Buffer Not Empty Flag 0: The receive buffer is empty 1: The receive buffer is not empty This bit can be set to 1 by hardware when there are data in RXDATA

Field	Name	R/W	Description
			register; this bit can be cleared by reading I2C_RXDATA; and be cleared by hardware when I2CEN=0.
3	ADDRMFLG	R	Slave Address Match Flag 0: The slave address does not match 1: The slave address matches When the received slave address matches any valid slave address, this bit is set to 1 by hardware. This bit can be cleared by software by setting ADDRMCCLR bit to 1; or be cleared by hardware when I2CEN=0.
4	NACKFLG	R	Receive Not Acknowledge Flag 0: NACK flag is not received 1: NACK flag is received This bit can be set to 1 by hardware when one byte is transmitted and NACK is received. It can be cleared by software by setting NACKCLR bit to 1; or be cleared by hardware when I2CEN=0.
5	STOPFLG	R	Stop Bit Detection Flag 0: No stop bit is detected 1: The stop bit is detected This bit can be set to 1 by hardware when the peripheral participates in transmission and the stop bit is detected on the bus. This bit can be cleared by software if the peripheral transmits the stop bit as the master or the peripheral is addressed correctly as the slave before this transmission, and STOPCLR=1; or be cleared by hardware when I2CEN=0.
6	TXCFLG	R	Transmit Data Complete Flag 0: Transmitting data is not completed 1: Transmitting data is completed This bit can be set to 1 by hardware when RELOADEN=0, ENDCFG=0 and NUMBYT data have been transmitted; be cleared when START=1 or STOP=1; or be cleared by hardware when I2CEN=0.
7	TXCRFLG	R	Transfer Complete Reload Flag 0: Transmission is completed 1: Transmission is completed to reload This bit can be set to 1 by hardware when RELOADEN=1 and NUMBYT data have been transmitted; it can be cleared by software by writing a non-zero value to NUMBYT; or be cleared by hardware when I2CEN=0. This bit works only in master mode, or in slave mode when SBCEN=1.
8	BERRFLG	R	Bus Error Flag 0: No bus error 1: Bus error occurred This bit can be set to 1 by hardware when wrong start bit or stop bit is detected; be cleared by software by setting BERRCLR bit; or be cleared by hardware when I2CEN=0.
9	ALFLG	R	Arbitration Lost Flag 0: No arbitration loss 1: Arbitration loss occurred This bit can be set to 1 by hardware when bus arbitration loss occurs; be cleared by software by setting ALCLR bit; or be cleared by hardware when I2CEN=0.
10	OVRURFLG	R	Overrun/Underrun Flag 0: No overrun/underrun 1: Overrun/Underrun occurs This bit can be set to 1 by hardware if overrun/underrun error occurs in slave mode when CLKSTRETCHD=1; be cleared by software by setting OVRURCLR bit; and be cleared by hardware when I2CEN=0.
11	PECEFLG	R	PEC Error in Reception Flag 0: No PEC error 1: PEC error occurs This bit can be set to 1 by hardware when the received PEC value does not match the value of PEC register. A NACK will be transmitted automatically when wrong PEC is received. This bit can be cleared by software by setting PECECLR bit; and be cleared by hardware when I2CEN=0. If SMBus mode is not supported, this bit will be reserved and

Field	Name	R/W	Description
			be forced to 0 by hardware.
12	TTEFLG	R	Timeout or Tlow Error Flag 0: No timeout error 1: Timeout error occurs This bit can be set to 1 by hardware when timeout or external clock timeout occurs; be cleared by software by setting TTECLR bit; and be cleared by hardware when I2CEN=0. If SMBus mode is not supported, this bit will be reserved and be forced to 0 by hardware.
13	SMBALTFLG	R	SMBus Alert Occur Flag 0: No SMBus alarm 1: SMBus alarm occurred This bit can be set to 1 by hardware if HADDREN=1 (configured by SMBus HOST) and ALTEN=1, and SMBALERT falling edge is detected on SMBALERT pin; be cleared by software by setting SMBALTCLR bit; and be cleared by hardware when I2CEN=0. If SMBus mode is not supported, this bit will be reserved and be forced to 0 by hardware.
14	Reserved		
15	BUSBSYFLG	R	Bus Busy Flag 0: The bus is idle (no communication) 1: The bus is busy (in the progress of communication) This bit can be set to 1 by hardware when a start bit is detected; be cleared by hardware when a stop bit is detected; or be cleared when I2CEN=0.
16	TXDIRFLG	R	Transfer Direction Flag Update when the address matching event occurs. 0: Write transmission; the slave enters receiving mode 1: Read transmission; the slave enters transmitting mode
23:17	ADDRCMFLG	R	Address Code Match Flag The received address is updated when the address match event occurs. 0: The address code does not match 1: The address code matches In 10-bit address, ADDRCMFLG provides the address after the first two bits of 10-bit address.
31:24	Reserved		

23.7.8 Interrupt flag clear register (I2C_INTFCLR)

Offset address: 0x1C

Reset value: 0x0000 0000

Field	Name	R/W	Description
2:0	Reserved		
3	ADDRMCLR	W	Slave Address Match Flag Clear Set this bit, and the ADDRMLG flag bit of I2C_STS register and START bit of I2C_CTRL2 register will be cleared.
4	NACKCLR	W	Receive Not Acknowledge Flag Clear Set this bit and NACKFLG flag bit of I2C_STS register will be cleared.
5	STOPCLR	W	Stop Bit Detection Flag Clear Set this bit and STOPFLG flag bit of I2C_STS register will be cleared.
7:6	Reserved		
8	BERRCLR	W	Bus Error Flag Clear Set this bit and BERRFLG flag bit of I2C_STS register will be cleared.
9	ALCLR	W	Arbitration Lost Flag Clear Set this bit and ALFLG flag bit of I2C_STS register will be cleared.

Field	Name	R/W	Description
10	OVRURCLR	W	Overflow/Underflow Flag Clear Set this bit and OVRURFLG flag bit of I2C_STS register will be cleared.
11	PECECLR	W	PEC Error in Reception Flag Clear Set this bit and PECEFLG flag bit of I2C_STS register will be cleared. If SMBus mode is not supported, this bit will be reserved and be forced to 0 by hardware.
12	TTECLR	W	Timeout or Tlow Error Flag Clear Set this bit and TTEFLG flag bit of I2C_STS register will be cleared. If SMBus mode is not supported, this bit will be reserved and be forced to 0 by hardware.
13	SMBALTCLR	W	SMBus Alert Occur Flag Clear Set this bit and SMBALTFLG flag bit of I2C_STS register will be cleared. If SMBus mode is not supported, this bit will be reserved and be forced to 0 by hardware.
31:14	Reserved		

23.7.9 PEC register (I2C_PEC)

Offset address: 0x20

Reset value: 0x0000 0000

Field	Name	R/W	Description
7:0	PEC	R	PEC Value Setup When PECEN=1, this bit field means the internal PEC value. This bit can be cleared by hardware when I2CEN=0.
31:8	Reserved		

23.7.10 Receive data register (I2C_RXDATA)

Offset address: 0x24

Reset value: 0x0000 0000

Field	Name	R/W	Description
7:0	RXDATA	R	8-Bit Receive Data Byte Data byte received from I2C bus.
31:8	Reserved		

23.7.11 Transmit data register (I2C_TXDATA)

Offset address: 0x28

Reset value: 0x0000 0000

Field	Name	R/W	Description
7:0	TXDATA	R/W	8-Bit Transmit Data Byte Data byte to be transmitted to I2C bus. This bit field can be set only when TXBEFLG=1.
31:8	Reserved		

24 Serial Peripheral Interface/On-chip Audio Interface (SPI/I2S)

24.1 Full Name and Abbreviation Description of Terms

Table 78 Full Name and Abbreviation Description of SPI Terms

Full name in English	English abbreviation
Most Significant Bit	MSB
Least Significant Bit	LSB
Master Out Slave In	MOSI
Master In Slave Out	MISO
Serial Clock	SCK
Serial Data	SD
Master Clock	MCK
Word Select	WS
Pulse-code Modulation	PCM
Inter-IC Sound	I2S
Transmit	TX
Receive	RX
Busy	BSY

24.2 Introduction

Include two SPIs: SPI1 and SPI2; both support I2S mode.

SPI interface can be configured to support SPI protocol and I2S audio protocol. It works in SPI mode by default, and the functions can be switched in I2S mode through software.

Serial peripheral interface (SPI) provides data transmitting and receiving functions based on SPI protocol, which allows chips to communicate with external devices in half duplex, full duplex, synchronous and serial modes, and can work in master or slave mode.

The on-chip audio interface (I2S) supports four audio standards: Philips I2S standard, MSB alignment standard, LSB alignment standard and PCM standard. It can work in master/slave mode of half-duplex communication.

24.3 Main Characteristics of SPI

- (1) Master and slave operation with 3-wire full duplex synchronous transmission and receiving
- (2) Simplex synchronous transmission can be realized by two wires (the third bidirectional data line can be included/not included)
- (3) Select 4-bit or 16-bit transmission frame format

- (4) Support multiple master device mode
- (5) Support special transmission and receiving mark and can trigger interrupt
- (6) Have SPI bus busy state flag
- (7) SPI supports Motorola mode
- (8) Fast communication in master/slave mode, up to 18MHz
- (9) Clock polarity and phase are programmable
- (10) Data sequence is programmable; select MSB or LSB first
- (11) Interrupt can be triggered by master mode fault, overrun and CRC error flag
- (12) Have DMA transmit and receive buffers
- (13) Calculation, transmission and verification can be conducted through hardware CRC
- (14) CRC error flag
- (15) Two 32-bit embedded RXFIFO and TXFIFO have DMA function

24.4 Main Characteristics of I2S

- (1) Have master/slave mode of simplex communication (only transmit/receive)
- (2) Four audio standards
 - I2S Philips standard
 - MSB alignment standard
 - LSB alignment standard
 - PCM standard
- (3) 16/24/32-bit data length can be selected
- (4) 16-bit or 32-bit channel length
- (5) Clock polarity is programmable
- (6) 16-bit data register is used for transmitting and receiving
- (7) MSB is always the first in the data direction
- (8) Transmitting and receiving supports DMA function
- (9) The master clock can output to an external audio component

24.5 SPI Functional Description

24.5.1 Description of SPI Signal Line

Table 79 SPI Signal Line Description

Pin name	Description
SCK	Master device: SPI clock outputs Slave device: SPI clock inputs
MISO	Master device: Input the pin and receive data Slave device: Output the pin and transmit data Data direction: From slave device to master device
MOSI	Master device: Output the pin and transmit data Slave device: Input the pin and receive data Data direction: From master device to slave device
NSS	Software NSS mode: NSS pin can be used for other purposes. Hardware NSS mode of master device: NSS outputs, in single-master mode, NSS OFF output: Operation of multiple master environments is allowed, Slave hardware NSS mode: The NSS signal is set to low level as the chip selection signal of the slave

24.5.2 Communication Format

In SPI communication, receiving data and transmitting data can be carried out at the same time. SCK transmits and samples the data on the data line synchronously. The communication format depends on the clock phase, clock polarity and data frame format. If the communication is normal, the master device and the slave device must have the same communication format.

24.5.2.1 Phase and polarity of clock signal

The clock polarity and clock phase are CPOL and CPHA bits of SPI_CTRL1 register.

Clock polarity CPOL means the level signal of SCK signal line when SPI is in idle state.

- When CPOL=0, SCK signal line is in idle state and at low level
- When CPOL=1, SCK signal line is in idle state and at high level

Clock phase CPHA means the sampling moment of data

- When CPHA=0, the signal on MOSI or MISO data line will be sampled by the “odd edge” on SCK clock line.
- When CPHA=1, the signal on MOSI or MISO data line will be sampled by the “even edge” on SCK clock line.

SPI can be divided into four modes according to the states of clock phase CPHA and clock polarity CPOL.

Table 80 Four Modes of SPI

SPI mode	CPHA	CPOL	Sampling moment	Idle SCK clock
0	0	0	Odd edge	Low level

SPI mode	CPHA	CPOL	Sampling moment	Idle SCK clock
1	0	1	Odd edge	High level
2	1	0	Even edge	Low level
3	1	1	Even edge	High level

Note:

- (1) To change CPOL and CPHA bits, SPI must be cleared and closed through SPIEN bit.
- (2) When SCK is in idle state, if CPOL=1, pull up SCK; if CPOL=0, pull up SCK.

24.5.2.2 Data frame format

Select LSB or MSB first by configuring LSBSEL bit of SPI_CTRL1 register. Select the data word length by configuring DSCFG bit of SPI_CTRL2 register; no matter which data word length is selected, it must be aligned with FRTCFG when read access is conducted to FIFO. When accessing SPI_DATA register, the data frames are always right aligned. In the process of communication, only the bits within the data word length range will be output with the clock.

24.5.3 NSS Mode

Software NSS mode: Select to enable or disable this mode by configuring SSEN bit of SPI_CTRL1 register, and the internal NSS signal level is driven by ISSEL bit of SPI_CTRL1 register.

Hardware NSS mode:

- Turn on NSS output: When SPI is in master mode, enable SSOEN bit, NSS pin will be pulled to low level and SPI will automatically enter the slave mode.
- Turn off NSS output: Operation is allowed in multiple master environments.

24.5.4 SPI Mode

24.5.4.1 Initialization of SPI master mode

In master mode, serial clock is generated on SCK pin.

Configure master mode

- Configure MSMCFG=1 in SPI_CTRL1 register, and set it as master mode
- Select the serial clock baud rate by configuring BRSEL bit in SPI_CTRL1 register
- Select the polarity and phase by configuring CPOL and CPHA bits in SPI_CTRL1 register
- Select the transmission mode by configuring RXOMEN, BMOEN and BMEN bits in SPI_CTRL1 register
- Select the data bit width by configuring DSCFG bit in SPI_CTRL2 register
- Turn on NSS pulse mode by configuring NSSPEN bit in SPI_CTRL2 register (when configuring this bit, CPHA bit must be set to 1)
- Set RXFIFO threshold value for triggering RXBNEFLG event by configuring FRTCFG bit in SPI_CTRL2 register
- If DMA function is used, it is required to configure LDTX and LDRX bits of SPI_CTRL2 register

- If CRC is used, it is required to set CRC polynomial as input and also set CRCEN bit
- Select LSB or MSB first by configuring LSBSEL in SPI_CTRL1 register
- NSS configuration:
 - NSS pin works in input mode: in hardware mode, it is required to connect NSS pin to high level during the entire data frame transmission; in software mode, it is required to set SSEN bit and ISSEL bit in SPI_CTRL1 register
 - NSS works in output mode and it is required to configure SSOEN bit of SPI_CTRL2 register
- Configure SPIEN bit in SPI_CTRL1 register to enable SPI

In master mode: MOSI pin is data output, while MISO is data input.

24.5.4.2 Initialization of SPI slave mode

In slave mode, SCK pin receives the serial clock transmitted from the master device.

Configuration of slave mode

- Configure MSMCFG=0 in SPI_CTRL1 register, and set it as slave mode
- Select the polarity and phase by configuring CPOL and CPHA bits in SPI_CTRL1 register
- Select the transmission mode by configuring RXOMEN, BMOEN and BMEN bits in SPI_CTRL1 register
- Select the data bit width by configuring DSCFG bit in SPI_CTRL2 register
- Turn on NSS pulse mode by configuring NSSPEN bit in SPI_CTRL2 register (when configuring this bit, CPHA bit must be set to 1)
- Set RXFIFO threshold value for triggering RXBNEFLG event by configuring FRTCFG bit in SPI_CTRL2 register
- If DMA function is used, it is required to configure LDTX and LDRX bits of SPI_CTRL2 register
- If CRC is used, it is required to set CRC polynomial as input and also set CRCEN bit
- Select LSB or MSB first by configuring LSBSEL in SPI_CTRL1 register
- NSS configuration:
 - In hardware mode: NSS pin must be at low level in the whole data frame transmission process
 - In software mode: Set SSEN bit in SPI_CTRL1 register and clear ISSEL bit
- Configure SPIEN bit in SPI_CTRL1 register to enable SPI

In slave mode: MOSI pin is data input, while MISO is data output.

24.5.4.3 Full duplex communication of SPI

Usually, SPI is configured as full duplex communication, and the shift registers of the master and the slave are connected through two unidirectional lines MOSI and MISO. During SPI communication, synchronous data transmission is conducted according to SCK clock edge. The data of the master are transmitted to the slave through MOSI pin, and the data of the slave are transmitted to the master through MISO pin. When the data transmission is completed, it means that the information is exchanged successfully.

24.5.4.4 Half-duplex communication of SPI

One clock line and one bidirectional data line

- Enable this mode by setting BMEN bit of SPI_CTRL1 register
- Control the data line to be input or output by setting BMOEN bit of SPI_CTRL1 register
- SCK pin is used as clock, MOSI pin is used in master device to transmit data, and MISO pin is used in slave device to transmit data

24.5.4.5 Simplex communication of SPI

One clock line and one unidirectional data line (receive-only or transmit-only)

In this mode, SPI mode is used as receive-only or transmit-only.

Transmit-only mode:

- Data are transmitted on transmit pin (MOSI in master mode, MISO in slave mode)
- Then the receive pin can be used as general-purpose I/O (MISO in master mode, MOSI in slave mode)

Receive-only mode:

- Turn off SPI output function by setting RXOMEN bit in SPI_CTRL1 register
- Release the transmit pin (MOSI in master mode, MISO in slave mode)
- In master mode, enable SPI to start communication, clear SPIEN bit of SPI_CTRL1 register and receiving data can be stopped immediately, not needing to read BSYFLG flag (always 1)
- In slave mode: Pull NSS to low level, and as long as SCK is pulsed by clock, SPI will always receive

24.5.4.6 Communication of multiple slave devices of SPI

SPI can be operated by multiple slave devices. The master device uses GPIO pin to manage the chip selection line of the slave device, and can control two or more independent slave devices.

The master device decides using which slave device to transmit data by pulling down the NSS pin of the slave device.

24.5.5 Data Transmitting and Receiving Process in Different SPI Modes

Table 81 Run Mode of SPI

Mode	Configure	Data pin
Full duplex mode of master device	BMEN=0, RXOMEN=0	MOSI transmits; MISO receives
Unidirectional receiving mode of master device	BMEN=0, RXOMEN=1	MOSI is not used; MISO receives
Bidirectional transmitting mode of master device	BMEN=1, BMOEN=1	MOSI transmits; MISO is not used
Bidirectional receiving mode of master device	BMEN=1, BMOEN=0	MOSI is not used; MISO receives
Full duplex mode of slave device	BMEN=0, RXOMEN=0	MOSI receives; MISO transmits
Unidirectional receiving mode of slave device	BMEN=0, RXOMEN=1	MOSI receives; MISO is not used
Bidirectional transmitting mode of slave device	BMEN=1, BMOEN=1	MOSI is not used; MISO transmits
Bidirectional receiving mode of slave device	BMEN=1, BMOEN=0	MOSI receives; MISO is not used

Figure 111 Connection in Full Duplex Mode

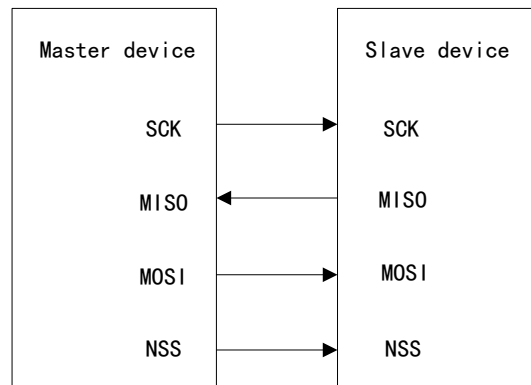

Figure 112 Connection in Half Duplex Mode

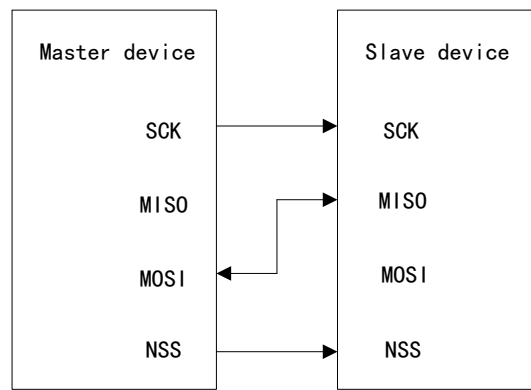

Figure 113 Connection in Simplex Mode (the master is used for receiving, while the slave is used for transmitting)

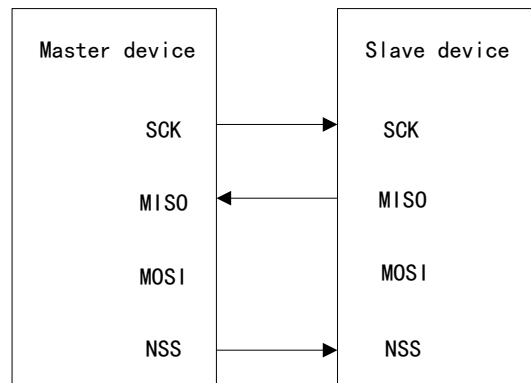
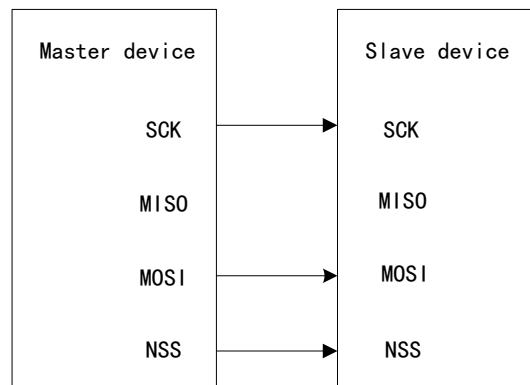

Figure 114 Connection in Simplex Mode (the master only transmits, while the slave receives)



24.5.5.1 Transmitting and receiving of data

In order to prevent overrun when the data frame is short and ensure that SPI can work continuously, all SPI data need to pass through the 32-bit embedded FIFO. Each direction will have its own FIFO, TXFIFO and RXFIFO.

Handle FIFO according to SPI simplex and duplex mode, data frame format, access size executed on FIFO data register and whether to use data package to process FIFO when accessing FIFO.

After read access to SPI_DATA register, the earliest values that have not been read yet and are stored in RXFIFO will be returned. After write access to SPI_DATA, the written data will be stored in TXFIFO at the end of the transmit queue. Read access must always be aligned with RXFIFO threshold value configured by FRTCFCG bit in SPI_CTRL2 register. The FTLSEL and FRLSEL bits indicate the current occupancy levels of the two FIFOs.

The read access to SPI_DATA register must be managed by RXBNEFLG event. When the data are stored in RXFIFO and reach the threshold value (defined by previous bit), this event will be triggered; when RXBNEFLG is cleared, RXFIFO will be regarded to be empty, and in the similar way, the write access to the data frame to be transmitted is managed by TXBEFLG event. When TXFIFO is less than or equal to half its capacity, RXBNEFLG event will be triggered; otherwise, TXBEFLG will be cleared, meanwhile, it will be regarded that there are data stored in TXFIFO. Therefore, when the data frame format is less than or equal to one byte, RXFIFO can store 4 data frames at most, and TXFIFO can store 3 data frames. When the software attempts to write more data to TXFIFO in 16-bit mode, this difference can prevent the three or eight data frames that have been stored in TXFIFO from being damaged. TXBEFLG and RXBNEFLG events can be polled or handled by interrupt.

24.5.5.2 Sequence processing

In transmitting data, multiple data can be formed into a sequence in order. When the transmission is started, TXFIFO will transmit continuously in order.

In single receive mode, in half duplex or simplex mode, when SPI is enabled, the master device will immediately receive the sequence until SPI is off or the single receive mode is off. When the data frame starts transmission, the slave cannot control the data sequence, so the slave must prepare the data before the transmission, to ensure there are data to be transmitted in TXFIFO.

When there are multiple slave devices, each sequence needs to be corresponding to different slave devices, so NSS pulse should be used to separate the sequence to ensure it is correct.

Note:

- (1) Check whether the data transmission is completed according to FTLSEL bit and BSYFLG bit, and the clock output will stop when the transmission is completed.
- (2) In packet mode, special attention should be paid to empty bytes when the data being transmitted are odd.
- (3) In single receive mode, the master device needs to disable SPI or single receive mode to stop clock output.
- (4) Master the correct receiving time to ensure the correct data transmission
- (5) The action of closing should be between the sampling time of first bit and the first bit of the next byte.

24.5.5.3 Data packing

If the data frame is less than or equal to one byte, when executing 16-bit read and write access to SPI_DATA register, the data will be packed automatically and double data can be processed in parallel. After conducting write access to SPI_DATA, 2-byte data will be transmitted; if the threshold value of RXFIFO is set to 16 bits, a receive RXBNEFLG event will be generated.

For a single RXBNEFLG event, the data receiver will perform one read operation to SPI_DATA, and only after that, can it obtain all data.

Note: The threshold value of RXFIFO should be consistent with the bit width of follow-up data access.

24.5.6 NSS Pulse Mode

NSS pulse mode can be set by configuring NSSPEN bit of SPI_CTRL1 register; this mode take effect only when SPI is configured as Motorola master mode and captures the first edge. In transmitting of this mode, NSS pulse is generated between two continuous data frames, and NSS will remain high for at least one cycle. NSS pulse mode allows the slave to latch data.

24.5.7 TI Mode

Master mode of TI protocol

SPI interface can be made compatible with master mode of TI protocol by configuring FRFCFG bit of SPI_CTRL2 register.

In master mode of TI protocol, it is unaffected by the setting of SPI_CTRL1 register, and the clock polarity, phase and NSS management will meet the requirements of TI protocol. In slave mode, SPI baud rate frequency divider is used to control MISO pin to make MISO pin to be in high-impedance state, and any baud rate can be used to ensure the best flexibility.

Generally the baud rate is set as the baud rate of external master clock, and the delay for MISO signal to become the high-impedance state depends on the baud rate set synchronously and through BRSEL bit of SPI_CTRL1 register internally. The formula is:

$$T_{\text{baud_rate}/2+4\times t_{\text{pclk}} < t_{\text{release}} < t_{\text{baud_rate}}+6\times t_{\text{pclk}}$$

Note: This function does not apply to Motorola SPI communication mode (FRFCFG bit is set to 0)

24.5.8 CRC Function

SPI module contains two CRC computing units, which are used for data receiving and data transmission respectively.

CRC computing units are used to define polynomials in SPI_CRCPOLY register (it should be odd, and does not support even number).

Enable CRC computing by configuring CRCEN bit in SPI_CTRL1 register; at the

same time, reset the CRC register (SPI_RXCRC and SPI_TXCRC).

CRC is managed by CPU during transmission

To obtain the CRC value of transmission calculation, after the last data is written to the transmit buffer, it is required to set CRCNXT bit of SPI_CTRL1; indicate that the hardware transmits the CRC value after the last data is transmitted, and the CRCNXT bit will be cleared; during CRC data transmission, CRC computing will be frozen.

The received CRC data will be stored in RXFIFO. A CRC transaction usually needs one more data frame to communicate at the end of the data sequence. However, when an 8-bit data frame checked by 16-bit CRC is set, two data frames are needed to transmit the complete CRC. When the last CRC data is received, the received value and the value of SPI_RXCRC register will be compared. By checking CRCEFLG flag bit in SPI_STS register, judge whether the data are damaged in the process of transmission. CRCEFLG bit can be cleared by writing 0. RXBNEFLG bit can be cleared by reading SPI_DATA register.

Sequence of clearing CRC values

- (1) Disable SPI (SPIEN=0)
- (2) Clear CRCEN bit
- (3) Set CRCEN bit to 1
- (4) Enable SPI (SPIEN=1)

Note: When SPI works in slave mode, the software must enable CRC operation when the clock is stable. And in the data phase and CRC phase, the NSS signal needs to be pulled down and maintained.

24.5.9 DMA Function

For high-speed data transmission, the request/response DMA mechanism in SPI improves the system efficiency and can transfer data to SPI transmit buffer promptly, and the receive buffer can read the data in time to prevent overflow.

When SPI only transmits data, it is only needed to enable DMA transmission channel.

When SPI only receives data, it is only needed to enable DMA receiving channel.

DMA function of SPI mode can be enabled by configuring TXDEN and RXDEN bits of SPI_CTRL2 register.

- When transmitting: When TXBEFLG flag bit is set to 1, issue the DMA request, DMA controller writes data to SPI_DATA, and then the TXBEFLG flag bit will be cleared.
- When receiving: When setting RXBNEFLG flag bit to 1, issue the DMA request, DMA controller reads data from SPI_DATA register, and then RXBNEFLG flag bit is cleared.

By monitoring BSYFLG flag bit, confirm whether SPI communication is over after DMA has transferred all data to be transmitted in transmitting mode, which can avoid damaging the transmission of last data.

DMA function with CRC

By the end of communication, if SPI enables both CRC operation and DMA function, transmitting and receiving of CRC bytes will be completed automatically. The CRCNXT bit is not controlled by software. The transmitting DMA channel counter of SPI must be set to the number that does not contain CRC data, but the DMA channel counter must contain the length of one more CRC data when receiving.

After reading CRC data in CRC check link, the values of SPI_TXCRC and SPI_RXCRC will be cleared automatically. Then continuous transmission can be realized by DMA circular mode (except in single receive mode).

At the end of data and CRC transmission, if CRCEFLG flag bit of SPI_STS register is set to 1, it indicates that an error occurred during transmission.

24.5.10 SPI Disable

After data transmission is over, end the communication by closing SPI module. When data are being transmitted or there are data in TXFIFO, it is not allowed to turn off SPI by operating SPIEN bit in SPI_CTRL1 register. If SPIEN=0 is set, the clock signal will be transmitted continuously until the peripheral is enabled again. Certain steps are required to turn off SPI in order to prevent the above situations.

Steps of turning off SPI

- (1) Wait for clearing FTLSEL
- (2) Wait for clearing BSYFLG flag bit
- (3) Wait for clearing FRLSEL
- (4) Disable SPI (SPIEN=0)

Steps of turning off SPI in some single receive mode

- (1) Wait for clearing RXOMEN or setting BMOEN to 1
- (2) Wait for clearing BSYFLG flag bit
- (3) Wait for clearing FRLSEL
- (4) Disable SPI (SPIEN=0)

24.5.11 SPI Interrupt

An interrupt can be triggered by the following events during SPI operation:

- TXFIFO prepares for loading
- RXFIFO receives data
- Master mode error
- CRC error
- TI frame format error

24.5.11.1 State flag bit

There are three flag bits for fully monitoring the state of SPI bus

Transmit buffer empty flag TXBEFLG

TXBEFLG=1 means that TXFIFO has space to store the transmitted data; TXBEFLG flag bit is connected to TXFIFO bit, and in the process of storing data, if the storage content of TXFIFO is less than or equal to FIFO/2, TXBEFLG flag bit is kept high. When the storage content of TXFIFO is greater than FIFO/2, TXBEFLG flag bit will be cleared. If TXBEIEN bit in SPI_CTRL2 register is set, an interrupt will be generated.

Receive buffer non-empty flag RXBNEFLG

RXBNEFLG flag bit depends on the value of FRTCFG bit in SPI_CTRL2 register:

- If FRTCFG=1, when the storage content of RXFIFO is greater than or equal to 8 bits, RXBNEFLG=1
- If FRTCFG=0, when the storage content of RXFIFO is greater than or equal to 16 bits, RXBNEFLG=1

RXBNEFLG flag bit will be cleared automatically if not in the above situations. If RXBNEIEN=1 in SPI_CTRL2 register, an interrupt will be generated.

Busy flag BSYFLG

BSYFLG flag is set and cleared by hardware, which can indicate the state of SPI communication layer. When BSYFLG=1, it indicates SPI is communicating. BSYFLG flag can be used to detect whether transmission is over to avoid damaging the last transmitted data.

BSYFLG flag will be cleared in the following situations

- End the transmission in master mode
- Master mode fault
- In slave mode, there is at least one SPI cycle between two data transmissions
- Disable SPI

During continuous communication:

- In master mode: BSYFLG=1 in the whole transmission process
- In slave mode: BSYFLG is kept low within one SCK clock cycle between transmission of each data

Note: It is best to use TXBEFLG and RXBNEFLG flags to process the transmitting and receiving of each data item

24.5.11.2 Error flag bit

Master mode error MEFLG

MEFLG is an error flag bit. The master mode error occurs when: in hardware NSS mode, the NSS pin of the master device is pulled down; in software NSS mode, ISSEL bit is cleared; MEFLG bit is set automatically.

Effect of master mode failure: MEFLG is set to 1, and if ERRIEN is set, SPI

interrupt will be generated; SPIEN is cleared (output stops, SPI interface is closed); MSMCFG is cleared and the device is forced to enter the slave mode. Operation of clearing the MEFLG flag bit: When MEFLG flag bit is set to 1, it is required to read or write SPI_STS register, and then write to SPI_CTRL1 register.

When MEFLG flag bit is 1, it is not allowed to set SPIEN and MSMCFG bits.

Overrun error OVRFLG

An overrun error will be generated when the following events occur

- When RXBNEFLG flag bit is still 1 after the master device has transmitted data
- When the space in RXFIFO cannot store the data to be received when receiving data
- When the software or DMA cannot read the data in RXFIFO in time
- When CRC is only enabled in receiving mode, RXFIFO is not available and the receive buffer is limited to the single data frame buffer

When an overrun error occurs: OVRFLG bit is set to 1; if ERRIEN bit is also set, an interrupt will be generated.

After an overrun error occurs, the data in the receiving buffer are not the data transmitted by the master device, and by reading SPI_DATA value, the data are the data not read before, and the subsequent data will be discarded.

OVRFLG flag can be cleared by reading SPI_DATA register and SPI_STS register according to the sequence.

CRC error flag bit CRCEFLG

Enable CRC operation by setting CRCEN bit of SPI_CTRL1 register, and CRC error flag can check whether the received data are valid.

When the value transmitted by SPI_TXCRC register does not match the value in SPI_RXCRC register, a CRC error will be generated, and CRCEFLG flag bit in SPI_STS register will be set to 1.

CRCEFLG can be cleared by writing 0 to CRCEFLG bit of SPI_STS register.

TI mode frame format error (FREFLG)

Under the slave device and in accordance with TI mode protocol, when a pulse appears in NSS during data communication, a TI mode frame format error will be caused. When TI mode frame format error occurs, FREFLG flag bit of SPI_STS register will be set to 1, SPI will not be disabled, NSS pulse will be ignored, and SPI will wait for the next NSS pulse before retransmission. As the error detection may cause the loss of two data bytes, the data may have been damaged.

FREFLG flag can be cleared by reading SPI_STS register. If ERRIEN bit is set, an interrupt will be generated when NSS error occurs. At this time, SPI is disabled because the consistency of data cannot be guaranteed. When SPI is enabled again, the master server needs to be reinitialized.

Table 82 SPI Interrupt Request

Interrupt flag	Interrupt event	Enable control bit	Clearing method
TXBEFLG	Transmit buffer empty flag	TXBEIEN	Write SPI_DATA register
RXBNEFLG	Receive buffer non-empty flag	RXBNEIEN	Read SPI_DATA register
MEFLG	Master mode failure event flag	ERRIEN	Read/Write SPI_STS register and then write SPI_CTRL1 register

Interrupt flag	Interrupt event	Enable control bit	Clearing method
OVRFLG	Overrun error flag		Read SPI_DATA register and then read SPI_STS register
CRCEFLG	CRC error flag		Write 0 to CRCEFLG bit
FREFLG	TI mode frame format error flag		Read SPI_STS register

24.6 I2S Functional Description

Enable I2S function by setting I2SMOD bit of SPI_I2SCFG.

I2S and SPI share four pins:

- SD: Serial data, transmitting and receiving the data of 2-way time division multiplexing channel
- WS: Chip selection, switching the data of left and right channels
- CK: Serial clock; the clock signal is output in master mode, and is input in slave mode
- MCK: Master clock; in master mode, when MCOEN bit of SPI_I2SPSC register is set to 1, it can be used as the pin for outputting the extra clock signal.

24.6.1 I2S Audio Standard

I2S audio standard is selected by setting I2SSSEL bit and PFSSEL bit of SPI_I2SCFG register, and four audio standards can be selected: I2S Philips standard, MSB alignment standard, LSB alignment standard and PCM standard. Except PCM standard, other audio standards have two channels: left and right channels.

The data length and channel length can be configured by DATALEN and CHLEN bits in SPI_I2SCFG register. The channel length must be greater than or equal to the data length. There are four data formats to transmit data: 16-bit data packed into 16-bit frame, 16-bit data packed into 32-bit frame, 24-bit data packed into 32-bit frame, and 32-bit data packed into 32-bit frame.

When the 16-bit data is extended to 32 bits, the first 16 bits are valid data, and the last 16 bits are forced to be 0. No external intervention is needed in this process.

Since the data buffers used for transmitting and receiving are all 16 bits, SPI_DATA needs to read/write twice when 24-bit and 32-bit data are transmitted. If DMA is used, it needs to be transmitted twice.

For all communication standards and data formats, the most significant bit of data is always transmitted first.

For time division multiplexing, the left channel is always transmitted first, and then the right channel is transmitted.

24.6.1.1 I2S Philips standard

In I2S Philips standard, the pin WS can indicate the data being transmitted comes from the left channel or the right channel.

In I2S Philips standard, both WS and SD change on the falling edge of CK clock signal.

The transmitter will change the data on the falling edge of the clock signal CK, while the receiver will change the data on the rising edge of the clock signal CK.

Figure 115 I2S Philips Protocol Waveform (16/32 bits)

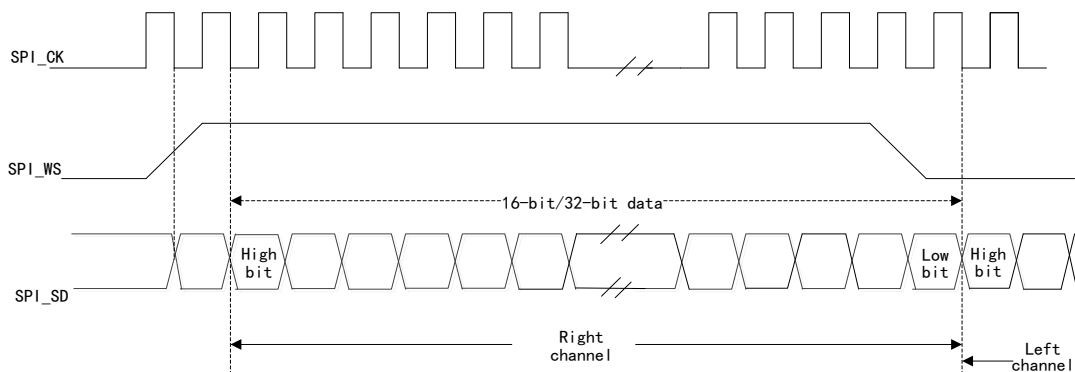
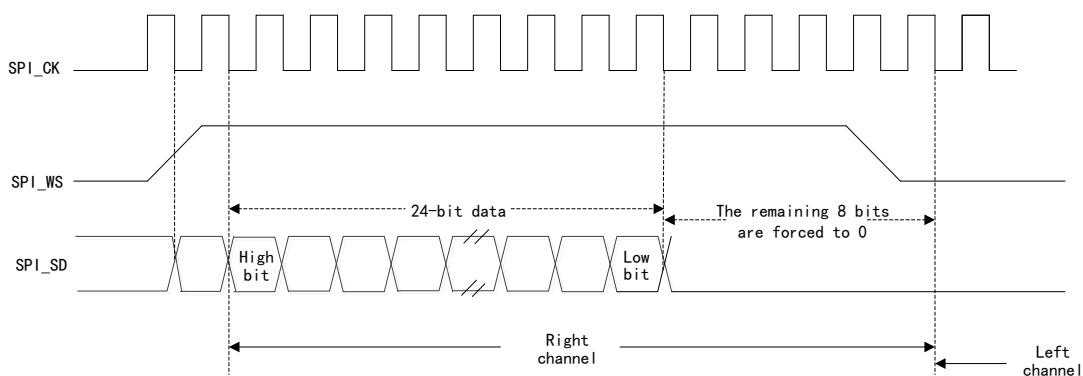

Figure 116 I2S Philips Protocol Waveform (24 bits)



In I2S Philips standard, if you want to transmit/receive 24-bit and 32-bit data, the SPI_DATA register needs to read/write twice; for example:

- If you need to transmit 0x9FBB88 (24-bit data), write 0x9FBB to SPI_DATA register for the first time, and write 0x88XX to the register for the second time.
- If you need to receive 0x9FBB88 (24-bit data), read out 0x9FBB from SPI_DATA register for the first time and read out 0x8800 from the register for the second time.

In I2S configuration, when selecting the frame format of extending from 16-bit data to 32-bit data frame, it is required to access SPI_DATA register. The remaining 16-bit data will be set to 0x0000 by hardware by force; for example:

- The data to be received or transmitted is 0x62d8, which becomes 0x62D80000 after it is expanded to 32 bits, and it is necessary to write 0x62D8 to SPI_DATA register or read out from SPI_DATA register.

Figure 117 I2S Philips Protocol Waveform (extending from 16 bits to 32 bits)

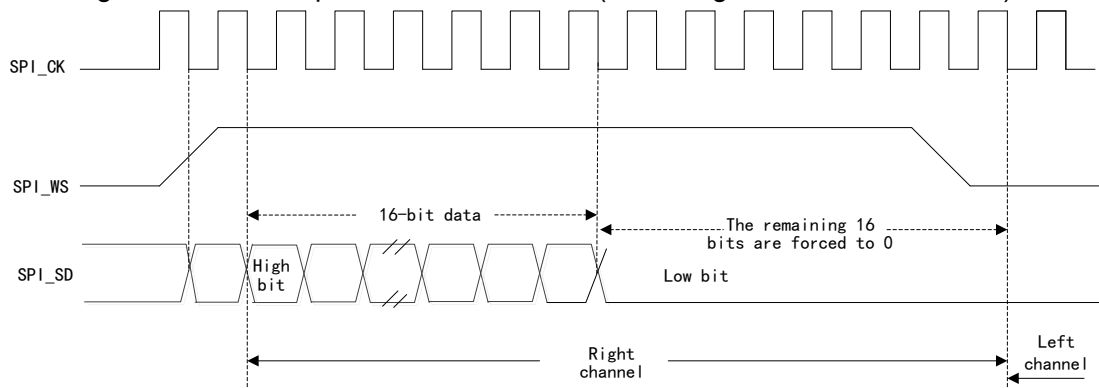

In the transmission process, the MSB should be written to the register SPI_DATA, and when TXBEFLG flag bit is set to 1, new data can be written; if there is corresponding interrupt, an interrupt can be generated.

In the receiving process, every time the MSB is received, the RXBNEFLG flag bit will be set to 1; if there is corresponding interrupt, an interrupt can be generated.

24.6.1.2 MSB alignment standard

In MSB standard, WS signal and the first data bit are generated at the same time. In the transmission process, the data is changed on the falling edge of the clock signal; in the receiving process, the data is read on the rising edge of the clock signal.

Figure 118 MSB Alignment Standard Waveform (16/32-bit data)

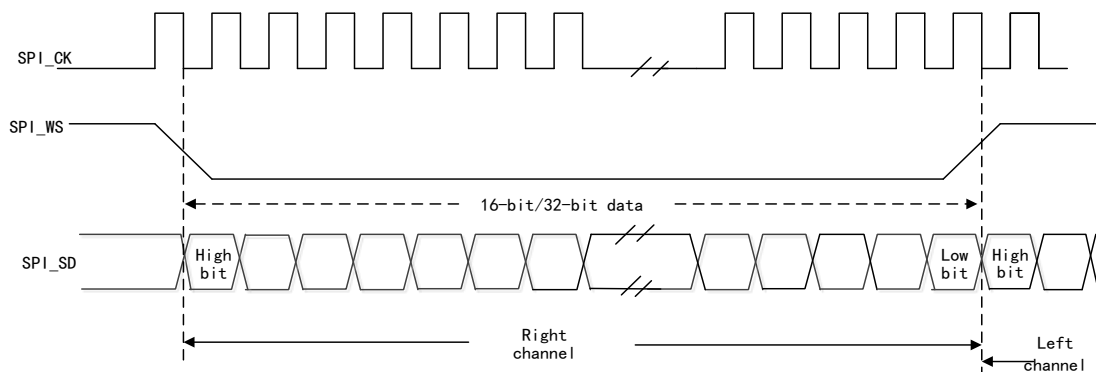

Figure 119 MSB Alignment Standard Waveform (24-bit data)

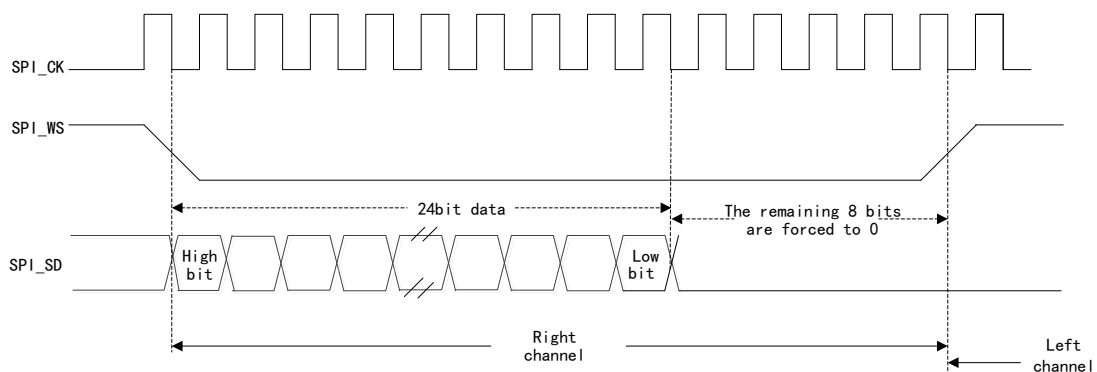
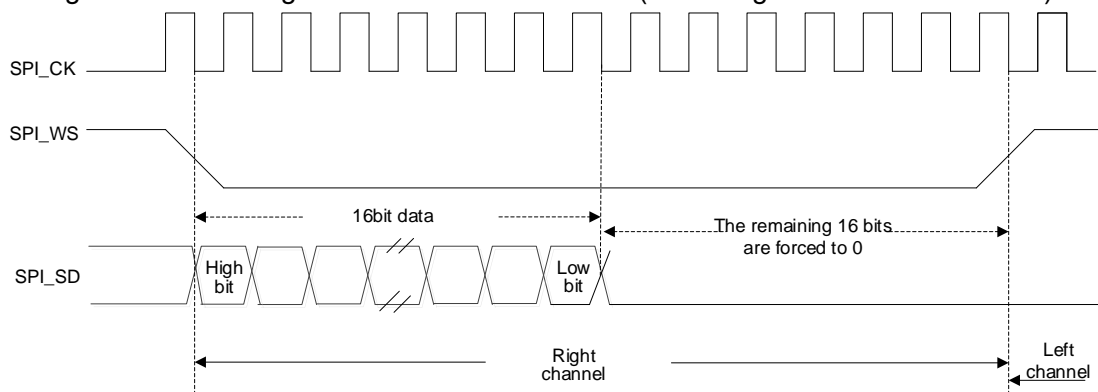

Figure 120 MSB Alignment Standard Waveform (extending from 16 bits to 32 bits)



24.6.1.3 LSB alignment standard

In the transmission process of LSB alignment standard, the data is changed on the falling edge of the clock signal; in the receiving process, the data is read on the rising edge of the clock signal. When the channel length is the same as the data length, the LSB alignment standard is the same as the MSB alignment standard. If the channel length is larger than the data length, the valid data of the LSB alignment standard is aligned with the lowest bit.

Figure 121 LSB Alignment Standard Waveform (16/32-bit data)

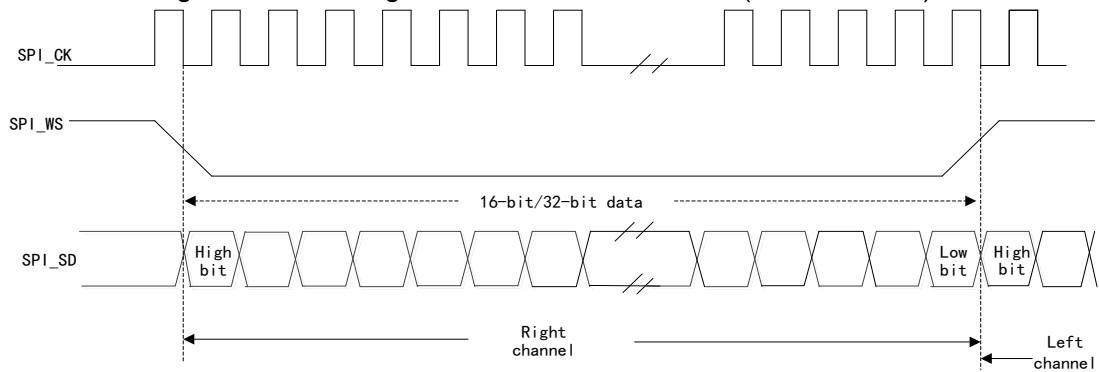
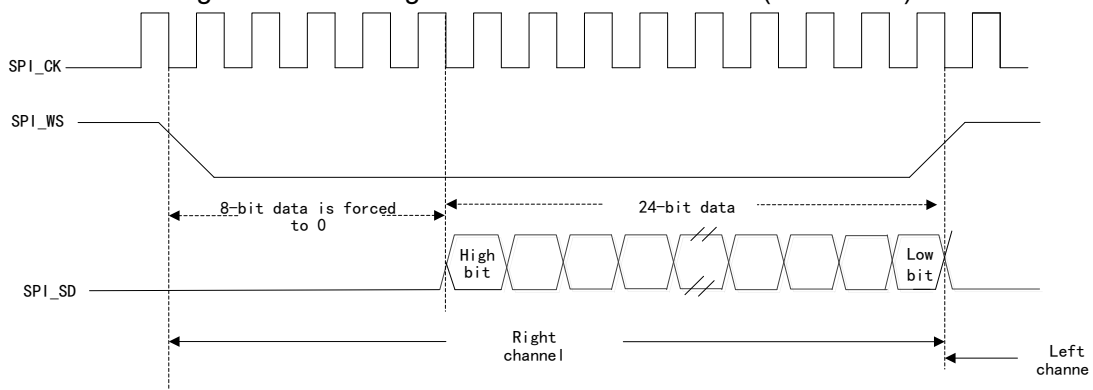

Figure 122 LSB Alignment Standard Waveform (24-bit data)



In the transmission process, if you want to transmit/receive 24-bit data, it is required to read/write the SPI_DATA register twice; for example:

- When you need to transmit 0x56EA98, write 0xXX56 to SPI_DATA register for the first time, and write 0xEA98 to SPI_DATA for the second time.
- When you need to receive 0x56EA98, read out 0x0056 from SPI_DATA register for the first time, and read out 0xEA98 from SPI_DATA register for the second time.

In I2S configuration, when selecting the frame format of extending from 16-bit data to 32-bit data frame, it is required to access SPI_DATA register, and the high 16-bit data will be set to 0x0000 by hardware by force; for example:

- The data to be received or transmitted is 0x98A5, which becomes 0x000098A5 after it is expanded to 32 bits, and it is necessary to write 0x98A5 to SPI_DATA register or read out from SPI_DATA register.

Figure 123 Under LSB Alignment Standard (extending from 16 bits to 32 bits)

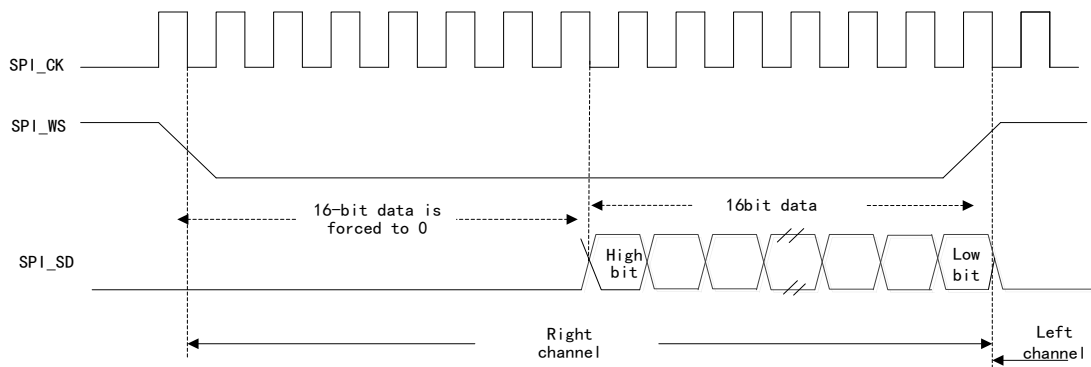

24.6.1.4 PCM standard

There is no sound channel selection in PCM standard. Short frame and long frame of PCM standard are selected by configuring PFSSEL bit in SPI_I2SCFG register.

In the master mode, the valid time of synchronous WS signal of the long frame structure is 13 bits.

Figure 124 PCM Standard Waveform

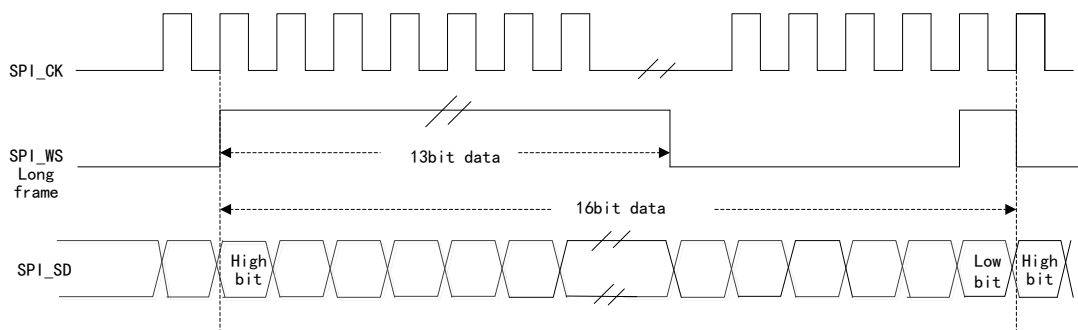

In the master mode, the length of the synchronous WS signal of the short frame structure is 1 bit.

Figure 125 PCM Standard Waveform

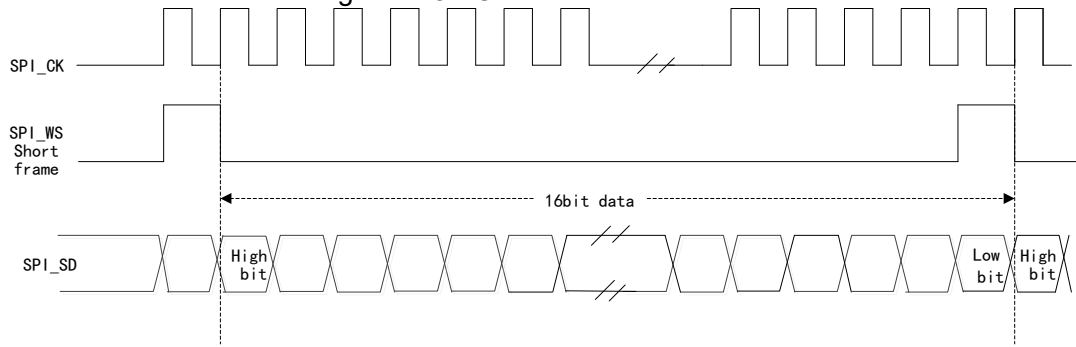

24.6.2 I2S Clock

The clock source of I2SxCLK is system clock (HSICLK, HSECLK or PLL of AHB clock)

The bit rate of I2S determines the data stream on I2S data line and the clock signal frequency of I2S.

- I2S bit rate = the number of bits per channel × the number of sound channels × audio sampling frequency
- There are two channels of 16 bit audio signal: I2S bit rate=16×2×Fs

The relationship between audio sampling frequency (Fs) and I2S bit rate (I2S) is defined by the following formula:

Table 83 Audio Sampling Frequency (Fs) Formula

MCOEN	CHLEN	Audio sampling frequency (Fs)
1	0	$I2SxCLK / [(16 \times 2) \times ((2 \times I2SPSC) + ODDPSC) \times 8]$
1	1	$I2SxCLK / [(32 \times 2) \times ((2 \times I2SPSC) + ODDPSC) \times 4]$
0	0	$I2SxCLK / [(16 \times 2) \times ((2 \times I2SPSC) + ODDPSC)]$
0	1	$I2SxCLK / [(32 \times 2) \times ((2 \times I2SPSC) + ODDPSC)]$

24.6.3 I2S Mode

Table 84 I2S Run Mode

Run mode	SD	WS	CK	MCK
Master transmitting	Output	Output	Output	Output/Not used
Master receiving	Input	Output	Output	Output/Not used
Slave transmitting	Output	Input	Input	Output/Not used
Slave receiving	Input	Input	Input	Output/Not used

24.6.3.1 I2S master mode configuration process

- Configure I2SPSC bit and ODDPSC bit of SPI_I2SPSC register to define the baud rate of serial clock and the actual frequency division factor corresponding to the audio sampling frequency.
- Configure CPOL bit of SPI_I2SCFG register to define the clock polarity of SPI in idle state.
- Configure I2SMOD bit of SPI_I2SCFG register to activate I2S function and configure I2SMOD and PFSSEL bits of SPI_I2SCFG register to

select I2S standard; configure DATALEN bit of SPI_I2SCFG register to select the data bits of the sound channel, and configure I2SMOD bit to select I2S master mode as transmitting terminal/receiving terminal.

- Configure SPI_CTRL2 register to select to enable the interrupt and DMA function or not (select required or not).
- Configure WS pin and CK pin to output mode; when MCOEN bit of SPI_I2SPSC is set to 1, the MCK pin should also be configured to output mode.
- Set the running mode of I2S by configuring the I2SMOD bit of SPI_I2SCFG.
- Set I2SEN bit of SPI_I2SCFG register to 1.

24.6.3.2 I2S master mode transmission process

When the data is written to the transmit buffer, the transmission will start, and the data will be transferred from the transmit buffer to the shift register, the TXBEFLG flag position is set to 1, and the SCHDIR flag bit indicates the corresponding sound channel of the currently transmitted data. And the value of SCHDIR flag bit will be updated when TXBEFLG flag bit is 1.

When transmitting the first bit of data, 16-bit data will be transferred to the 16-bit shift register in parallel, and then transmitted out from the pin MISO/SD in serial. The next data needs to be written to SPI_DATA register when TXBEFLG flag bit is 1. If TXBEIEN bit of SPI_CTRL2 is 1, an interrupt will be generated.

Before the completion of the current data transmission, write the next data to be transmitted to ensure continuous transmission of audio data.

When I2S is closed, I2SEN can be cleared only when the flag bit TXBEFLG is 1 and BSYFLG is 0.

24.6.3.3 I2S master mode receiving process

RXBNEFLG flag is used to control the receiving sequence. RXBNEFLG flag indicates whether the receive buffer is empty; when the receive buffer is full, the RXBNEFLG flag bit will be set to 1. If RXBNEIEN bit of SPI_CTRL2 is configured, an interrupt will occur and after the user reads out the data from SPI_DATA register, the RXBNEFLG flag bit will be cleared. Make sure to receive new data after reading operation; otherwise, overrun will occur and the OVRFLG flag bit will be set to 1.

The value of SCHDIR should be updated immediately after receiving data, and it depends on the WS signal generated by I2S.

Regardless of the data type and the channel length, the audio data is always received in the form of 16 bits. According to the configured data and the length of the channel, the data needs to be transmitted to the receive buffer once or twice. Turn off the I2S function, and for different audio protocols, the data length and channel length operation steps are as follows:

The data length is 16 bits, and 32-bit channel length (DATALEN=00, CHLEN=1, I2SSSEL=10) in LSB alignment mode

- Wait until the penultimate RXBNEFLG is set to 1
- Wait for 17 I2S clock cycles (software delay)
- I2SEN flag bit is cleared

The data length is 16 bits, and 32-bit channel length (DATALEN=00, CHLEN=1, I2SSSEL=10) in MSB alignment mode

- Wait until the last RXBNEFLG is set to 1
- Wait for one I2S clock cycle (software delay)
- I2SEN flag bit is cleared

All the other situations

- Wait until the penultimate RXBNEFLG is set to 1
- Wait for one I2S clock cycle (software delay)

- I2SEN flag bit is cleared

BSYFLG flag clock is low during data transmission

24.6.3.4 I2S slave mode configuration process

The configuration method of slave mode is basically the same as that of master mode. In slave mode, the clock signal and WS signal are provided by external I2S device instead of I2S.

- Configure I2SMOD bit of SPI_I2SCFG register to activate I2S function.
- Configure I2SSSEL bit of SPI_I2SCFG register to select the I2S standard; configure DATALEN[1:0] bit of SPI_I2SCFG register to select the bits of data; configure CHLEN bit of SPI_I2SCFG register to select the data bits per channel; configure I2SMOD bit of SPI_I2SCFG register to select I2S slave mode as transmitting terminal/receiving terminal.
- Configure SPI_CTRL2 register to select to enable the interrupt and DMA function or not (select required or not).
- Set I2SEN bit of SPI_I2SCFG register to 1.

24.6.3.5 I2S slave mode transmission process

Enable the slave device, write the data to the I2S data register, the external master device will start to communicate, and the external master device will transmit the clock signal, and when the data transmission starts, the transmitting process will begin.

When the first bit data is transmitted, the 16-bit data will be transferred to the 16-bit shift register in parallel, and then transmitted out from the pin MOSI/SD in series. When the data is transferred from the data register to the shift register, the TXBEFLG flag bit is set to 1; at this time if TXBEIEN bit of SPI_CTRL2 register is set, an interrupt will be generated. In order to ensure the continuity of data transmission, the next data should be written to SPI_DATA register before the data transmission is completed; otherwise, “underrun” will occur, and the UDRFLG flag bit will be set to 1.

SCHDIR bit of SPI_STS register indicates the channel corresponding to the transmitted data. In the slave mode, the SCHDIR bit is determined by the WS signal of the external master device.

In MSB and LSB alignment mode of I2S, the first data written to the data register corresponds to the data of the left channel.

Close I2S, and after the TXBEFLG flag bit is set to 1, BSYFLG flag bit can be cleared.

24.6.3.6 I2S slave mode receiving process

RXBNEFLG flag is used to control the receiving sequence. The RXBNEFLG flag indicates whether the receive buffer is empty; after the receive buffer is full, the RXBNEFLG flag bit will be set to 1; if RXBNEIEN bit of SPI_CTRL2 register is set, an interrupt will occur, and after the data are read out from SPI_DATA register, RXBNEFLG flag bit will be cleared; make sure to receive new data after read operation; otherwise, “overrun” will occur, and the OVRFLG flag bit will be set to 1.

The value of SCHDIR should be updated immediately after receiving data, and it depends on the WS signal generated by I2S.

Regardless of the data type and the channel length, the audio data is always

received in the form of 16 bits. According to the configured data and the length of the channel, the data needs to be transmitted to the receive buffer once or twice. Close I2S, and when receiving the last RXBNEFLG set to 1, I2SEN flag bit will be cleared.

24.6.4 I2S Interrupt

24.6.4.1 State flag bit

There are four state flag bits in I2S to monitor the state of I2S bus.

Transmit buffer empty flag bit TXBEFLG

When the TXBEFLG flag bit is 1, it indicates that the transmit buffer is empty, and the data to be transmitted can be written to the transmit buffer; after data is written, the TXBEFLG flag bit will be cleared. (When I2S is closed, the TXBEFLG flag bit is 0).

Receive buffer non-empty flag bit RXBNEFLG

When the RXBNEFLG flag bit is 1, it indicates that the receive buffer has data to be received; after read operation is performed on the SPI_DATA register, RXBNEFLG flag bit will be cleared.

Busy flag bit BSYFLG

When the BSYFLG flag bit is 1, it indicates that I2S is in communication state (set and cleared by hardware), but in the master receiving mode, the BSYFLG flag bit is always 0 during the receiving period.

When I2S is closed and data transmission is over, the BSYFLG flag bit will be cleared.

During continuous communication

- In the master transmitting mode, the BSYFLG flag bit is always high during the transmission period.
- In the slave mode, during transmission of each data item, the BSYFLG flag bit is set to 0 within one I2S clock cycle.

Channel flag bit SCHDIR

In the transmitting mode, SCHDIR flag bit is refreshed when TXBEFLG flag bit is high, indicating the channel of the data transmitted on SD pin at this time. If underrun error occurs in the transmission process of slave mode, the value of SCHDIR flag bit is invalid, and the communication can be started after turning off I2S function and then turning it on.

In the receiving mode, SCHDIR flag bit is refreshed when SPI_DATA register receives the data, indicating the channel of the received data. If overrun error occurs, the SCHDIR flag bit is invalid, and the communication can be started after turning off I2S function and then turning it on.

As there is no channel selection in PCM standard, the SCHDIR flag bit is meaningless.

When OVRFLG and UDRFLG flag bits of SPI_STS register are 1 and ERRIEN bit of SPI_CTRL2 is 1, an interrupt will be generated. Clear the flag by reading the value of SPI_STS register.

24.6.4.2 Error flag bit

I2S includes two error flag bits

Underrun flag bit UDRFLG

In the transmitting mode, if new data to be transmitted is written to SPI_DATA register before the data is transmitted, UDRFLG flag bit will be set to 1; at this time if ERRIEN bit of SPI_CTRL2 register is set to 1, an interrupt will be generated.

This flag bit will take effect only after I2SMOD bit of SPI_I2SCFG is set to 1.

Clear the UDRFLG flag bit by reading SPI_STS register.

Overrun flag bit OVRFLG

In the receiving mode, if a new data is received before the data is read, OVRFLG flag bit will be set to 1. At this time if ERRIEN bit of SPI_CTRL2 register is set to 1, an interrupt will be generated, indicating the occurrence of the error.

Read SPI_DATA register to return the last correctly received data, and all the other newly received data will be lost.

OVRFLG flag can be cleared by first reading SPI_STS register and then reading SPI_DATA register.

Table 85 I2S Interrupt Request

Interrupt flag	Interrupt event	Enable control bit	Clearing method
TXBEFLG	Transmit buffer empty flag	TXBEIEN	Write SPI_DATA register
RXBNEFLG	Receive buffer non-empty flag	RXBNEIEN	Read SPI_DATA register
OVRFLG	Underrun flag bit	ERRIEN	Read SPI_STS register
UDRFLG	Overrun flag bit		Read SPI_STS register Read SPI_DATA register again

24.6.4.3 DMA function

In I2S mode, the work mode of DMA is the same as that of SPI, except that it does not support CRC function.

24.7 Register Address Mapping

Table 86 SPI and I2S Register Address Mapping

Register name	Description	Offset address
SPI_CTRL1	SPI control register 1	0x00
SPI_CTRL2	SPI control register 2	0x04
SPI_STS	SPI state register	0x08
SPI_DATA	SPI data register	0x0C
SPI_CRCPOLY	SPI CRC polynomial register	0x10
SPI_RXCRC	SPI receive CRC register	0x14

Register name	Description	Offset address
SPI_TXCRC	SPI transmit CRC register	0x18
SPI_I2S_CFG	SPI_I2S configuration register	0x1C
SPI_I2SPSC	SPI_I2S prescaler register	0x20

24.8 Register Functional Description

These peripheral registers can be operated by half word (16 bits) or word (32 bits).

24.8.1 SPI control register 1 (SPI_CTRL1) (not used in I2S mode)

Offset address: 0x00

Reset value: 0x0000

Field	Name	R/W	Description
0	CPHA	R/W	<p>Clock Phase Configure</p> <p>This bit indicates on the edge of which clock to start sampling</p> <p>0: On the edge of No. 1 clock</p> <p>1: On the edge of No. 2 clock</p> <p>Note: This bit cannot be modified during communication. Except that CRC function is used in TI mode, this bit is not used in I2S mode and SPI TI mode.</p>
1	CPOL	R/W	<p>Clock Polarity Configure</p> <p>The state maintained by SCK when SPI is in idle state.</p> <p>0: SCK low level</p> <p>1: SCK high level</p> <p>Note: This bit cannot be modified during communication. Except that CRC function is used in TI mode, this bit is not used in I2S mode and SPI TI mode.</p>
2	MSMCFG	R/W	<p>Master/Salve Mode Configure</p> <p>0: Configure as slave mode</p> <p>1: Configure as master mode</p> <p>Note: This bit cannot be modified during communication.</p>
5:3	BRSEL	R/W	<p>Baud Rate Divider Factor Select</p> <p>000: DIV=2</p> <p>001: DIV=4</p> <p>010: DIV=8</p> <p>011: DIV=16</p> <p>100: DIV=32</p> <p>101: DIV=64</p> <p>110: DIV=128</p> <p>111: DIV=256</p> <p>Baud rate=Fmaster/DIV</p> <p>Note: This bit cannot be modified during communication</p>
6	SPIEN	R/W	<p>SPI Device Enable</p> <p>0: Disable</p> <p>1: Enable</p> <p>Note: When SPI device is closed, please operate according to the process of closing SPI.</p>
7	LSBSEL	R/W	<p>LSB First Transfer Select</p> <p>0: First transmit the most significant bit (MSB)</p> <p>1: First transmit the least significant bit (LSB)</p>

Field	Name	R/W	Description
8	ISSEL	R/W	Internal Slave Device Select Determine the level on NSS pin This bit can be set effectively only when CTRL1_SSEN=1.
9	SSEN	R/W	Software Slave Device Enable 0: Disable 1: Enable When SSEN is set, the level of NSS pin is determined by SSEN.
10	RXOMEN	R/W	Receive Only Mode Enable 0: Transmit and receive at the same time 1: Receive-only mode RXOMEN bit and BMEN bit together determine the transmission direction in the two-line and two-way mode. In the configuration of multiple slave devices, in order to avoid data transmission conflict, it is necessary to set RXOMEN bit to 1 on the slave devices that are not accessed.
11	CRCLSEL	R/W	CRC Length Select 0: Use 8-bit CRC 1: Use 16-bit CRC Note: This bit can be written only when SPIEN=0; otherwise, an error will occur.
12	CRCNXT	R/W	CRC Transfer Next Enable 0: Next value to be transmitted is from transmit buffer 1: Next value to be transmitted is from transmit CRC register Note: After the last data is written to SPI_DATA register, set CRCNXT bit immediately.
13	CRCEN	R/W	CRC Calculate Enable 0: CRC check is disabled 1: CRC check is enabled CRC check function only applies to full duplex mode; only when SPIEN=0, can this bit be changed.
14	BMOEN	R/W	Bidirectional Mode Output Enable 0: Disable (receive-only mode) 1: Enable (transmit-only mode) When BMEN=1, namely in single-line bidirectional mode, this bit decides the transmission direction of transmission line.
15	BMEN	R/W	Bidirectional Mode Enable 0: Double-line bidirectional mode 1: Single-line bidirectional mode Single-line bidirectional transmission means: transmission between MOSI pin of data master and MISO pin of slave.

24.8.2 SPI control register 2 (SPI_CTRL2)

Offset address: 0x04

Reset value: 0x0700

Field	Name	R/W	Description
0	RXDEN	R/W	Receive Buffer DMA Enable When RXDEN=1, once RXBNEFLG flag is set, DMA request will be issued. 0: Disable 1: Enable
1	TXDEN	R/W	Transmit Buffer DMA Enable When this bit is set, once TXBEFLG flag is set, DMA request will be issued. 0: Disable 1: Enable

Field	Name	R/W	Description
2	SSOEN	R/W	SS Output Enable SS output in master mode 0: SS output is disabled, and it can work in multi-master mode. 1: SS output is enabled, and it cannot work in multi-master mode. Note: Unavailable in I2S and SPI TI modes.
3	NSSPEN	R/W	NSS Pulse Management Enable 0: Disable 1: Enable Note: During continuous transmission, it is allowed to generate NSS pulse between transmission of two data. During single data transmission, NSS pin will be forced to be pulled up at the end of transmission. This bit is invalid when CPHA=1 or FRFCFG=1. This bit can be written only when SPIEN=0. Unavailable in I2S and SPI TI modes.
4	FRFCFG	R/W	Frame Format Configure 0: SPI Motorola mode 1: SPI TI mode Note: This bit can be written only when SPIEN=0. Unavailable in I2S mode.
5	ERRIEN	R/W	Error interrupt Enable 0: Disable 1: Enable When an error occurs, ERRIEN bit controls whether to generate the interrupt.
6	RXBNEIEN	R/W	Receive Buffer Not Empty Interrupt Enable 0: Disable 1: Enable When RXBNEFLG flag bit is set to 1, an interrupt request will be generated
7	TXBEIEN	R/W	Transmit Buffer Empty Interrupt Enable 0: Disable 1: Enable When TXBEFLG flag bit is set to 1, an interrupt request will be generated
11:8	DSCFG	R/W	Data Size Configure Configure the bit width of SPI transmission date: 0000: Reserved 0001: Reserved 0010: Reserved 0011: 4 bits 0100: 5 bits 0101: 6 bits 0110: 7 bits 0111: 8 bits 1000: 9 bits 1001: 10 bits 1010: 11 bits 1011: 12 bits 1100: 13 bits 1101: 14 bits 1110: 15 bits 1111: 16 bits Note: When reserved bit is written by software, the value will be forced to be 0111 (8 bits) Not used in I2S mode

Field	Name	R/W	Description
12	FRTCFG	R/W	FIFO Reception Threshold Configure Configure FIFO threshold, and when the value exceeds this threshold, RXBNEFLG will occur 0: 16 bits 1: 8 bits Note: Unavailable in I2S mode
13	LDRX	R/W	Last DMA Receive These bits are used in data packing mode to define the total number received by DMA to be odd or even. 0: Even 1: Odd Note: These bits are meaningful only when RXDEN bit of SPI_CTRL2 register is set and the packing mode is enabled. This bit can be written only when SPIEN=0. Not used in I2S mode.
14	LDTX	R/W	Last DMA Transmit These bits are used in data packing mode to define the total number transmitted by DMA to be odd or even. 0: Even 1: Odd Note: These bits are meaningful only when RXDEN bit of SPI_CTRL2 register is set and the packing mode is enabled. This bit can be written only when SPIEN=0. Not used in I2S mode.
15	Reserved		

24.8.3 SPI state register (SPI_STS)

Offset address: 0x08

Reset value: 0x0002

Field	Name	R/W	Description
0	RXBNEFLG	R	Receive Buffer Not Empty Flag This bit indicates that the receive buffer is empty or not 0: Empty 1: Not empty
1	TXBEFLG	R	Transmit Buffer Empty Flag This bit indicates that the transmit buffer is empty or not 0: Not empty 1: Empty
2	SCHDIR	R	Sound Channel Direction Flag 0: Indicate that the left channel is transmitting or receiving the required data 1: Indicate that the right channel is transmitting or receiving the required data Note: Not used in SPI mode, without left and right channels in PCM mode.
3	UDRFLG	R	Underrun Occur Flag This bit indicates the underrun occurs or not 0: Not occur 1: Occurred This flag bit is set by hardware and reset by software. Not used in SPI mode

Field	Name	R/W	Description
4	CRCEFLG	RC_W0	CRC Error Occur Flag This bit indicates whether the received CRC value matches the value of RXCRC register 0: Match 1: Not match This bit is set by hardware and reset by software. Not used in I2S mode
5	MEFLG	R	Mode Error Occur Flag This bit indicates mode error occurs or not 0: Not occur 1: Occurred This bit can be set by hardware and reset by software. Not used in I2S mode
6	OVRFLG	R	Overrun Occur Flag This bit indicates overrun occurs or not 0: Not occur 1: Occurred This bit can be set by hardware and reset by software.
7	BSYFLG	R	Busy Flag This bit indicates the work state of SPI 0: SPI is idle 1: SPI is communicating This bit can be set or reset by hardware
8	FREFLG	R	Frame Format Error Flag 0: Not occur 1: Occurred Note: This bit is set to 1 by hardware and cleared when reading SPI_STS register.
10:9	FRLSEL	R	FIFO Receive Level Select 00: FIFO is empty 01: FIFO/4 10: FIFO/2 11: FIFO is full Note: This bit is set to 1 and cleared by hardware. It is not used in 2S mode and SPI single receiving mode with CRC check.
12:11	FTLSEL	R	FIFO Transmit Level Select 00: FIFO is empty 01: FIFO/4 10: FIFO/2 11: FIFO is full (it can be considered as full when the threshold value of FIFO is greater than 1/2) Note: This bit is set to 1 and cleared by hardware. It is not used in I2S mode
15:13	Reserved		

24.8.4 SPI data register (SPI_DATA)

Offset address: 0x0C

Reset value: 0x0000

Field	Name	R/W	Description
15:0	DATA	R/W	<p>Transmit Receive Data register</p> <p>Store the data to be transmitted or received.</p> <p>When writing this register, the data will be written to the transmit buffer; when reading this register, the data in receive buffer will be read.</p> <p>The size of the buffer is consistent with the length of the data frame, that is, for 8-bit data, DATA[7:0] will be used when transmitting and receiving data, and DATA[15:8] is invalid; for 16-bit data, DATA[15:0] will be used when transmitting and receiving data.</p>

24.8.5 SPI CRC polynomial register (SPI_CRCPOLY) (not used in I2S mode)

Offset address: 0x10

Reset value: 0x0007

Field	Name	R/W	Description
15:0	CRCPOLY	R/W	<p>CRC Polynomial Value Setup</p> <p>This register contains CRC polynomial of CRC computing, which can be modified and the reset value is 0x0007.</p>

24.8.6 SPI receive CRC register (SPI_RXCRC) (not used in I2S mode)

Offset address: 0x14

Reset value: 0x0000

Field	Name	R/W	Description
15:0	RXCRC	R	<p>Receive Data CRC Value</p> <p>The CRC data of receive bytes calculated by hardware are stored in this register; the bits and the length of data frames are consistent, that is, if the received data are 8 bits, the CRC computing is made based on CRC8; if the received data are 16 bits, the CRC computing is made based on CRC16.</p> <p>When CRCEN is set, the hardware clears the register.</p> <p>Note: When BSYFLG bit is set to 1, the value of reading RXCRC register may be wrong.</p>

24.8.7 SPI transmit CRC register (SPI_TXCRC) (not used in I2S mode)

Offset address: 0x18

Reset value: 0x0000

Field	Name	R/W	Description
15:0	TXCRC	R	<p>Transmit Data CRC Value</p> <p>The CRC data of transmitted bytes calculated by hardware are stored in TXCRC; the bits and the length of data frames are consistent, that is, if the transmitted data are 8 bits, the CRC computing is made based on CRC8; if the transmitted data is are 16 bits, the CRC computing is made based on CRC16.</p> <p>Note: When BSYFLG bit is set to 1, the value of reading RXCRC register may be wrong.</p>

24.8.8 SPI_I2S configuration register (SPI_I2SCFG) (not applicable in SPI mode)

Offset address: 0x1C

Reset value: 0x0000

Field	Name	R/W	Description
0	CHLEN	R/W	Channel Length Configure The channel length refers to the data bits per audio channel 0: 16-bit width 1: 32-bit width Write operation is meaningful only when DATALEN=00 for this bit; otherwise, the channel length will be fixed as 32 bits by hardware. Note: This bit can be set only when I2S is closed. Not used in SPI mode.
2:1	DATALEN	R/W	Length of Data To Be Transferred Configure 00: 16-bit data length 01: 24-bit data length 10: 32-bit data length 11: Not allowed Note: This bit can be set only when I2S is closed. Not used in SPI mode.
3	CPOL	R/W	Steady State Clock Polarity Select Level state when I2S clock is in static state 0: Low level 1: High level Note: This bit can be set only when I2S is closed. Not used in SPI mode.
5:4	I2SSSEL	R/W	I2S Standard Select 00: I2S Philips standard 01: High-byte alignment standard (left alignment) 10: Low-byte alignment standard (right alignment) 11: PCM standard Note: This bit can be set only when I2S is closed. Not used in SPI mode.
6	Reserved		
7	PFSSSEL	R/W	PCM Frame Synchronization Mode Select 0: Synchronization of short frames 1: Synchronization of long frames Note: This bit is meaningful only when I2SSSEL=11. Not used in SPI mode.
9:8	I2SMOD	R/W	I2S Master/Slave Transmit/Receive Mode Configure 00: Slave device transmits 01: Slave device receives 10: Master device transmits 11: Master device receives Note: This bit can be set only when I2S is closed. Not used in SPI mode.
10	I2SEN	R/W	I2S Enable 0: I2S is disabled 1: I2S is enabled Note: It is not used in SPI mode.
11	MODESEL	R/W	SPI/I2S Mode Select 0: Select SPI mode 1: Select I2S mode Note: This bit can be set only when SPI or I2S is closed.
15:12	Reserved		

24.8.9 SPI_I2S prescaler register (SPI_I2SPSC) (not used in SPI mode)

Offset address: 0x20

Reset value: 0x0002

Field	Name	R/W	Description
7:0	I2SPSC	R/W	I2S Linear Prescaler Factor Configure Disabl setting I2SPSC [7:0]=0 or I2SPSC [7:0]=1 Note: This bit can be set only when I2S is closed. This bit is used only when I2S is in master device mode. Not used in SPI mode.
8	ODDPSC	R/W	Configure the prescaler factor to be odd 0: Actual division factor=I2SPSC*2 1: Actual division factor=(I2SPSC*2)+1 Note: This bit can be set only when I2S is closed. This bit is used only when I2S is in master device mode. Not used in SPI mode.
9	MCOEN	R/W	Master Device Clock Output Enable 0: Disable 1: Enable Note: This bit can be set only when I2S is closed. This bit is used only when I2S is in master device mode. Not used in SPI mode.
15:10	Reserved		

25 Controller Area Network (CAN)

25.1 Full Name and Abbreviation Description of Terms

Table 87 Full Name and Abbreviation Description of Terms

Full name in English	English abbreviation
First Input First Output	FIFO
Request	REQ

25.2 Introduction

CAN is abbreviation of Controller Area Network, and is serial communication protocol of ISO international standardization and supports CAN Protocol 2.0A and 2.0B. In CAN protocol, the transmitter 345chmitt345345 the message to all receivers in the form of broadcast. When the node receives the message, it will go through the filter group and decide whether the message is needed according to the identifier. This design saves the CPU overhead.

25.3 Main Characteristics

- (1) Support CAN protocol 2.0A and 2.0B
- (2) The maximum baud rate of communication is 1Mbit/s
- (3) Transmission function
 - There are three transmit mailboxes
 - The priority of transmitting message can be configured
 - Record the transmission time
- (4) Receiving function
 - Have two receive FIFO with three depth levels
 - Have 14 filter groups.
 - Record the receiving time

25.4 Functional Description

25.4.1 Characteristics of CAN Physical Layer

There can be multiple communication nodes on the CAN bus, each node consists of a CAN controller and a transceiver. The controller and transceiver are connected through CAN_TX and CAN_RX to transmit logic signals; the transceiver and bus are connected through CAN_High and CAN_Low to transmit differential signals.

25.4.2 Message Structure

Figure 126 Standard Data Frame

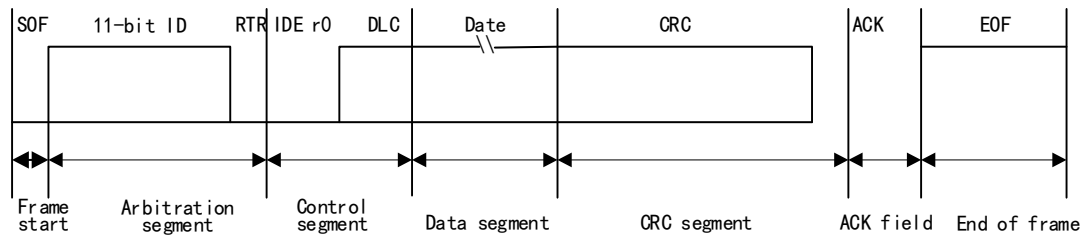
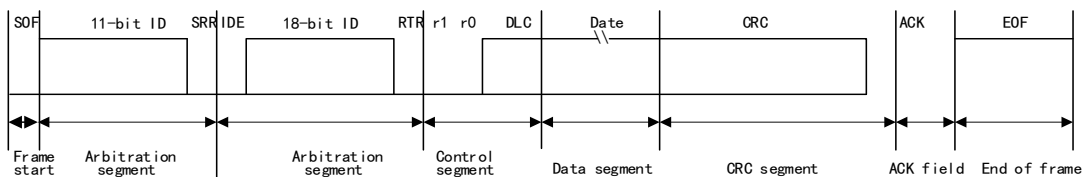

Figure 127 Extended Data Frame



Note:

- (1) Frame start: used to inform each node that there will be data for transmission.
- (2) Arbitration segment: It is used to decide which message can be transmitted when multiple messages are transmitted. Main content of this segment is ID information, the ID in standard format is 11 bits, and the ID in extended format is 29 bits.
- (3) Control segment: The main content of this segment is data length code (DLC), which is used to indicate how many bytes the data segment has in the message. The data segment has up to 8 bytes.
- (4) Data segment: Include the data information to be transmitted by the node.
- (5) CRC segment: CRC check code is used to ensure correct transmission of the messages.
- (6) ACK segment: This segment includes ACK slot bit and ACK delimiter bit. The transmitting node in ACK slot 346chmitt346346 recessive bits, while the receiving node 346chmitt346346 the dominant bit in this bit to acknowledge.
- (7) Frame end: Seven recessive bits transmitted by the transmitting nodes are used to indicate the end.

25.4.3 Working Mode

CAN has three main working modes: initialization mode, normal mode and sleep mode.

25.4.3.1 Initialization mode

Set the INITREQ bit of the configuration register CAN_MCTRL to 1 to request to enter the initialization mode; clear the INITFLG bit to confirm entering the initialization mode.

Clear the INITREQ bit of the configuration register CAN_MCTRL to request to exit the initialization mode; clear the INITFLG bit to confirm exiting the initialization mode.

Message receiving and transmitting is disabled in initialization mode.

25.4.3.2 Normal mode

Clear the INITREQ bit of the configuration register CAN_MCTRL through software to request to enter the normal mode from the initialization mode; wait for the hardware to clear the INITFLG bit to enter the normal mode.

Message receiving and transmitting is allowed in normal mode.

25.4.3.3 Sleep mode

Set the SLEEPREQ bit of the configuration register CAN_MCTRL to 1 to request to enter the sleep mode.

The clock of CAN stops work in sleep mode, the software can normally access the mailbox register, and the CAN is in low-power state.

25.4.4 Communication Mode

There are four communication modes: silent mode, loopback mode, silent loopback mode and normal mode. Different communication modes can be selected only in initialization mode.

25.4.4.1 Silent mode

Set the SILMEN bit of the configuration register CAN_BITTIM to 1 and select the silent mode.

In this mode, only recessive bit (logic 1) can be transmitted to the bus, while the dominant bit (logic 0) cannot be transmitted, and the data can be received from the bus.

Figure 128 CAN Works in Silent Mode

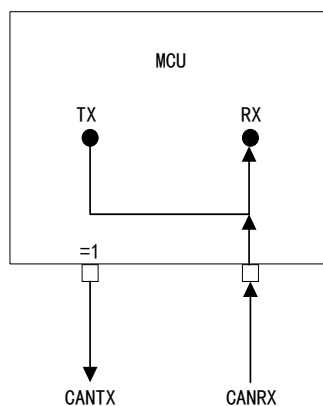

25.4.4.2 Loopback mode

Set the LBKMEN bit of the configuration register CAN_BITTIM to 1 and select the loopback mode.

In this mode, the transmitted data are directly transmitted to the input end for receiving, the data are not received from the bus, and all data can be transmitted to the bus.

Figure 129 CAN Works in Loopback Mode

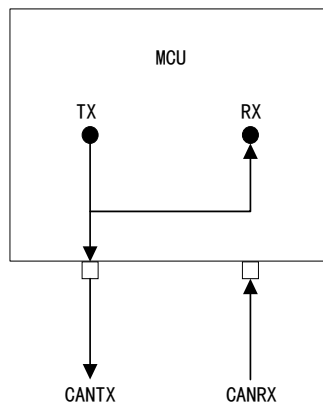

25.4.4.3 Loopback silent mode

Set the LBKMEN and SILMEN bits of the configuration register CAN_BITTIM to 1 and select the loopback silent mode.

In this mode, the transmitted data are directly transmitted to the input end for receiving, and the data are not received from the bus; only recessive bit (logic 1) can be transmitted to the bus, while the dominant bit (logic 0) cannot be transmitted.

Figure 130 CAN Works in Silent Loopback Mode

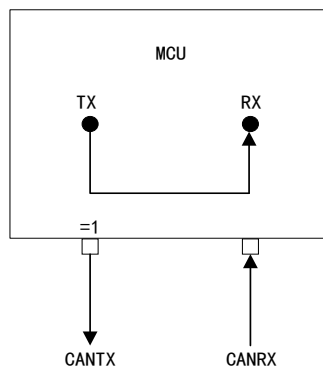

25.4.4.4 Normal mode

In this mode, data can be transmitted to the bus and be received from the bus.

Figure 131 CAN Works in Normal Mode

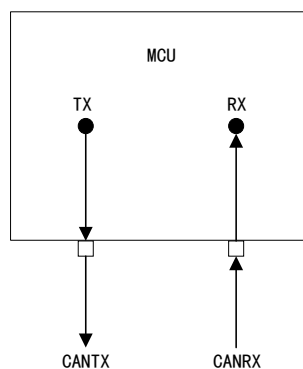

25.4.5 Data Transmission

25.4.5.1 Conversion of transmitting mailbox state

Conversion process of transmitting mailbox state:

- (1) First select an empty mailbox to set, submit the transmitting request to the CAN bus controller by setting the TXMREQ bit of the configuration register CAN_TXMIDx to 1, and then the mailbox immediately enters the registration state.
- (2) When multiple mailboxes are in the registered state, conduct priority scheduling. When an mailbox has the highest priority, it will enter the predetermined state.
- (3) When the message in the transmitting mailbox is transmitted to the bus, it will enter the transmitting state.
- (4) After the message is transmitted successfully, the mailbox will become idle again.

25.4.5.2 Transmitting priority

When multiple messages are waiting for transmitting, determine the transmitting sequence through the TXFPCFG bit of the configuration register CAN_MCTRL:

- When the TXFPCFG bit is set to 0, the priority is determined by the message identifier, the identifier is the lowest, the priority is the highest, the identifier is equal, and the message with small mailbox number will be transmitted first
- When the TXFPCFG bit is set to 1, the priority will be determined by the sequence of transmitting request

25.4.5.3 Abort

Transmitt the abort request by setting the ABREQFLG bit of the configuration register CAN_TXSTS to 1.

If the mailbox is in registered or predetermined state, stop transmitting the request immediately; if the mailbox is in the transmitting state, there are two conditions: one is that the mailbox is successfully transmitted, the mailbox becomes empty, in such case, the TXSUSFLG bit of the CAN_TXSTS register is set to 1 by hardware; the other is that the mailbox fails to 349chmitt349, the mailbox becomes predetermined and the transmitting request is aborted.

25.4.5.4 Automatic retransmission is disabled

Generally, in time triggered communication mode, automatic retransmission should be disabled.

In the mode that the automatic retransmission is disabled, the message is transmitted only once, and no matter what the result is (success, error or arbitration loss), the hardware will not 349chmitt349 the message again automatically.

When the transmitting process is finished, set the REQCFGL bit of the CAN_TXSTS register to 1, and the transmitting result will be on the TXSUSFLG, ARBLSTFLG and TXERRFLG bits

25.4.6 Data Receiving

25.4.6.1 Receive FIFO

CAN has two receive FIFOs, each FIFO has three mailboxes, the FMNUM[1:0] bit of the register CAN_RXF reflects the number of messages currently stored; set the RFOM bit to 1 to release the output mailbox of receive FIFO; FFULLFLG is the full state flag bit; FOVRFLG is overrun state flag bit.

25.4.6.2 Receive FIFO state conversion

At the beginning FIFO is in empty state, and after receiving the message, it will become registered.

When FIFO is in registered state and three mailboxes are full, after receiving next effective message, it will enter the overrun state, and there are two situations for loss of messages in overrun state:

- If FIFO lock function is disabled, the finally received message will be covered by new message
- If FIFO lock function is enabled, the newly received message will be discarded

25.4.7 Filtering Mechanism

Function of the filter: The receiving node decides whether the message is needed according to the message identifier, and only the required message will be received after filtering. CAN controller has 14 filter groups.

25.4.7.1 Bit width

Each group of filters can configure two kinds of bit width.

Figure 132 One 32-bit Filter

ID	CAN_FiBANK1 [31:24]	CAN_FiBANK1 [23:16]		CAN_FiBANK1 [15:8]	CAN_FiBANK1 [7:0]			
mapping	STDID [10:3]	STDID [2:0]	EXTID [17:13]	EXTID [12:5]	EXTID [4:0]	IDTYP ESEL	TXRFR EQ	0

Figure 133 Two 16-bit Filters

ID	CAN_FiBANK1 [15:8]	CAN_FiBANK1 [7:0]			CAN_FiBANK2 [15:8]	CAN_FiBANK2 [7:0]				
mapping	STDID [10:3]	STDID [2:0]	TXRFR REQ	IDTYP ESEL	EXTID [17:15]	STDID [12:5]	STDID [2:0]	TXRFR EQ	IDTYP ESEL	EXTID [17:15]

25.4.7.2 Filtering mode

Mask bit mode

In this mode, it is only required to use some bits of the message identifier as a list to form the mask, and the message ID should be the same as the mask, and then the message can be received

Table 88 Mask Bit Mode Example

ID	1	0	1	1	0	0	1	0
Mask	1	0	1	1	1	0	0	1
Screened ID	1	X	1	1	0	X	X	0

Identifier list mode

In this mode, each bit of the message ID needs to be the same as the filter identifier, and then the message can be received.

Table 89 Identifier List Mode Example

ID	1	1	1	0	1	0	0	1	1
ID	1	1	1	0	1	0	0	1	1

ID	1	1	1	0	1	0	0	1	1
Screened ID	1	1	1	0	1	0	0	1	1

25.4.7.3 Filter priority

The priority rules are as follows:

- The priority of the filter with bit width of 32 bits is higher than that with bit width of 16 bits
- Under the condition of the same bit width, the priority of the identifier list mode is higher than that of mask bit mode
- Under the condition of the same bit width and mode, the priority of the small filtering number is high

25.4.8 Bit Timing and Baud Rate

25.4.8.1 Bit timing

The CAN peripheral bit timing of APM32 contains three segments: synchronization segment (SYNC_SEG), time segment 1 (BS1) and time segment 2 (BS2), and the sampling points are at the junction of BS1 and BS2 segments.

- Synchronization segment (SYNC_SEG): This bit occupies one time cell
- Time segment 1 (BS1): This segment occupies one to 16 time cells, and it contains PROP_SEG and PHASE_SEG1 in CAN standard
- Time segment 2 (BS2): This segment occupies one to eight time cells, and it represents PHASE_SEG2 in CAN standard

25.4.8.2 Calculation of baud rate

Time of BS1 segment: $T_{s1} = T_q * (TIMSEG1[3:0] + 1)$

Time of BS2 segment: $T_{s2} = T_q * (TIMSEG2[2:0] + 10)$

Time of one data bit: $T_{1bit} = 1T_q + T_{s1} + T_{s2}$

Baud rate = $1 / T_{1bit}$

$T_q = (BRPSC + 1) * TPCLK$

25.4.9 Error Management

Transmitt the error counter through the TXERRCNT bit of the configuration register CAN_ERRSTS and receive the error counter through the RXERRCNT bit of the register CAN_ERRSTS to reflect the error management of CAN bus.

Control the generation of interrupt in error state through the ERRIEN bit of the configuration register CAN_INTEN.

25.4.9.1 Bus-off recovery

When the TXERRCNT of the CAN error state register is greater than 255, the CAN bus controller will enter the bus-off state, then the BOFLG bit of the register CAN_ERRSTS is set to 1, and in this state, the CAN bus controller cannot receive and 351chmitt351 messages.

Decide the bus-off recovery mode through the ALBOFFM bit of the configuration register CAN_MCTRL:

- If the ALBOFFM bit is set to 1, once the hardware detects 11 continuous recessive bits for 128 times, it will exit the bus-off state automatically;

- If the ALBOFFM bit is set to 0, after the software requests to enter and then exit the initialization mode, it will exit the bus-off state.

25.4.10 Interrupt

Events generating transmitting interrupt:

- The hardware sets REQCFG0 bit of the register CAN_TXSTS to 1, and the transmitting mailbox 0 becomes idle
- The hardware sets REQCFG1 bit of the register CAN_TXSTS to 1, and the transmitting mailbox 1 becomes idle
- The hardware sets REQCFG2 bit of the register CAN_TXSTS to 1, and the transmitting mailbox 2 becomes idle

Events generating FIFO0 interrupt:

- Set the FMNUM0[1:0] bit of the register CAN_RXF0 to a number rather than 0 by the hardware, and FIFO0 will receive a new message
- Set the FFULLFLG0 bit of the register CAN_RXF0 to 1 by the hardware, and FIFO0 will be full
- Set the FOVRFLG0 bit of the register CAN_RXF0 to 1 by the hardware and FIFO0 will overrun

Events generating FIFO1 interrupt:

- Set the FMNUM1[1:0] bit of the register CAN_RXF1 to a number rather than 0 by the hardware, and FIFO1 will receive a new message
- Set the FFULLFLG1 bit of the register CAN_RXF1 to 1 by the hardware, and FIFO1 will be full
- Set the FOVRFLG1 bit of the register CAN_RXF1 to 1 by the hardware and FIFO1 will overrun

Events generating state change and error interrupt:

- Set the SLEEPEN bit of the register CAN_INTEN to 1 by the hardware and it will enter the sleep mode
- Set the WUPIEN bit of the register CAN_INTEN to 1 by the hardware and interrupt enable will be woken up
- Set the ERRWFLG bit of the register CAN_ERRSTS to 1 by the hardware, and it means that the number of errors has reached the threshold
- Set the ERRPFLG bit of the register CAN_ERRSTS to 1 by the hardware, and it means that the number of errors has reached the threshold of passive error
- Set the LERRC[2:0] bit of the register CAN_ERRSTS by the hardware, and it indicates the condition of last error

Figure 134 Event Flag and Interrupt Generation

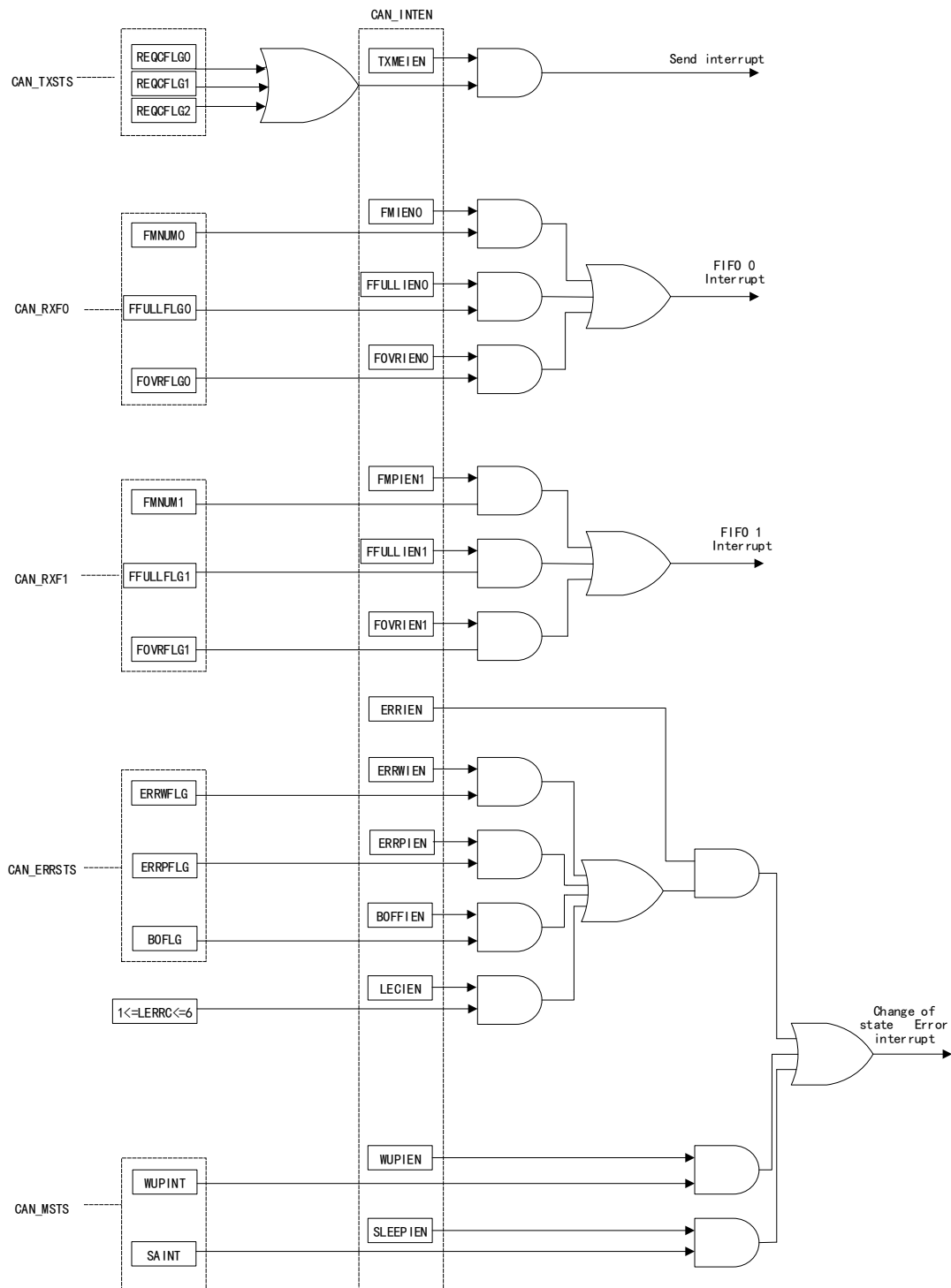

25.5 Register Address Mapping

Table 90 CAN Register Address Mapping

Register name	Description	Offset address
CAN_MCTRL	CAN main control register	0x00

Register name	Description	Offset address
CAN_MSTS	CAN main state register	0x04
CAN_TXSTS	CAN transmit state register	0x08
CAN_RXF0	CAN receive FIFO 0 register	0x0C
CAN_RXF1	CAN receive FIFO 1 register	0x10
CAN_INTEN	CAN interrupt enable register	0x14
CAN_ERRSTS	CAN error state register	0x18
CAN_BITTIM	CAN bit timing register	0x1C
CAN_TXMIDx	Transmit mailbox identifier register	0x180, 0x190, 0x1A0
CAN_TXDLENx	Transmit mailbox data length register	0x184, 0x194, 0x1A4
CAN_TXMDLx	Transmit mailbox low-byte data register	0x188, 0x198, 0x1A8
CAN_TXMDHx	Transmit mailbox high-byte data register	0x18C, 0x19C, 0x1AC
CAN_RXMIDx	Receive FIFO mailbox identifier register	0x1B0, 0x1C0
CAN_RXDLENx	Receive FIFO mailbox data length register	0x1B4, 0x1C4
CAN_RXMDLx	Receive FIFO mailbox low-byte data register	0x1B8, 0x1C8
CAN_RXMDHx	Receive FIFO mailbox high-byte data register	0x1BC, 0x1CC
CAN_FCTRL	CAN filter main control register	0x200
CAN_FMCFG	CAN filter mode configuration register	0x204
CAN_FSCFG	CAN filter bit width configuration register	0x20C
CAN_FFASS	CAN filter FIFO association register	0x214
CAN_FACT	CAN filter activation register	0x21C
CAN_FiBANKx	Register x of CAN filter group i	0x240..0x2AC

25.6 Register Functional Description

25.6.1 CAN Control and State Register

25.6.1.1 CAN main control register (CAN_MCTRL)

Offset address: 0x00

Reset value: 0x0001 0002

Field	Name	R/W	Description
0	INITREQ	R/W	Request to Enter Initialization Mode 0: Enter the normal work mode from the initialization mode 1: Enter the initialization mode from the normal work mode

Field	Name	R/W	Description
1	SLEEPREQ	R/W	Request to Enter Sleep Mode 0: Exit the sleep mode 1: Request to enter the sleep mode. If the AWUPCFG bit is set to 1, when the RX signal detects CAN message, this bit will be cleared by hardware; after reset, reset this bit to 1; after reset, it will enter the sleep mode.
2	TXFPCFG	R/W	Transmit FIFO Priority Configure This bit is used to determine which parameters determine the transmission priority when multiple messages are waiting for transmission. 0: Determined by the message identifier 1: Determined by the sequence of transmission request
3	RXFLOCK	R/W	Receive FIFO Locked Mode Configure This bit is used to determine whether FIFO is locked when receiving overrun, and how to deal with the next received message when the message of the receive FIFO has not been read out. 0: Unlocked; If the message of the receive FIFO is not read out, the next received message will cover the original message 1: Locked; when the message of the received FIFO is not read out, the next received message will be discarded
4	ARTXMD	R/W	Automatic Retransmission Message Disable 0: Automatic retransmission is enabled, and the message will be retransmitted automatically until it is transmitted successfully 1: Automatic retransmission is disabled and the message is transmitted only once
5	AWUPCFG	R/W	Automatic Wakeup Mode Configure 0: Software wakes up the sleep mode by clearing the SLEEPREQ bit of the CAN_MCTRL register 1: Hardware wakes up the sleep mode by detecting CAN message
6	ALBOFFM	R/W	Automatic Leaving Bus-Off Status Condition Management 0: After the software resets the INITREQ bit of the CAN_MCTRL register to 1 and then clears it, when the hardware detects 11 continuous recessive bits for 128 times, it will exit from the bus-off state 1: When the hardware detects 11 continuous recessive bits for 128 times, it will exit from the bus-off state automatically
14:7	Reserved		
15	SWRST	R/S	Software Reset CAN 0: Work normally 1: CAN is reset by force, and after reset, CAN enters the sleep mode; the hardware will clear this bit automatically
16	DBGFRZE	R/W	Debug Freeze 0: Invalid 1: During debugging, CAN cannot receive/transmit, but it still can read and write and control the receive FIFO normally
31:17	Reserved		

25.6.1.2 CAN main state register (CAN_MSTS)

Offset address: 0x04

Reset value: 0x0000 0C02

Field	Name	R/W	Description
0	INITFLG	R	Being Initialization Mode Flag This bit is set to 1 or cleared by hardware. 0: Exit the initialization mode 1: Being in the initialization mode; this bit is confirmation for initialization request bit of the CAN_MCTRL register.

Field	Name	R/W	Description
1	SLEEPFLG	R	Being Sleep Mode Flag This bit is set to 1 or cleared by hardware 0: Exit the sleep mode 1: Being in the sleep mode; this bit is confirmation for sleep moderequest bit of the CAN_MCTRL register.
2	ERRIFLG	RC_W1	Error Interrupt Occur Flag This bit is set to 1 by hardware and written to 1 and cleared by software. 0: Not occur 1: Occurred
3	WUPIFLG	RC_W1	Wakeup Interrupt Occur Flag When entering the sleep mode and detecting SOP wake-up, the bit is set to 1 by hardware; it is written to 1 and cleared by software. 0: Failed to wake up from the sleep mode 1: Woke up from the sleep mode
4	SLEEPIFLG	RC_W1	Being Sleep Mode Interrupt Flag When entering the sleep mode, this bit is set to 1 by hardware and corresponding interrupt will be triggered; when exiting the sleep mode, this bit is cleared by hardware and is written as 1 and cleared by software. 0: Failed to enter the sleep mode 1: Entered the sleep mode
7:5	Reserved		
8	TXMFLG	R	Being Transmit Mode Flag 0: CAN is not in transmission mode 1: CAN is in transmission mode
9	RXMFLG	R	Being Receive Mode Flag 0: CAN is not in receiving mode 1: CAN is in receiving mode
10	LSAMVALUE	R	CAN Rx Pin Last Sample Value
11	RXSIGL	R	CAN Rx Pin Signal Level
31:12	Reserved		

25.6.1.3 CAN transmit state register (CAN_TXSTS)

Offset address: 0x08

Reset value: 0x1C00 0000

Field	Name	R/W	Description
0	REQCFLG0	RC_W1	Mailbox 0 Request Completed Flag When the last transmission or abortion request of the mailbox 0 is completed, this bit is set to 1 by hardware; when receiving the transmission request, this bit is cleared by hardware; it is written to 1 or cleared by software. 0: Being transmitted 1: Transmission completed
1	TXSUSFLG0	RC_W1	Mailbox 0 Transmission Success Flag When mailbox 0 attempts to transmit successfully, this bit is set to 1 by hardware; and written to 1 and cleared by software. 0: Last transmission attempt failed 1: Last transmission attempt succeeded
2	ARBLSTFLG0	RC_W1	Mailbox 0 Arbitration Lost Flag When the mailbox 0 loses arbitration, this bit is set to 1 by hardware; and written to 1 and cleared by software. 0: Meaningless 1: Lost

Field	Name	R/W	Description
3	TXERRFLG0	RC_W1	Mailbox 0 Transmission Error Flag When mailbox 0 fails to transmit, this bit is set to 1 by hardware; and written to 1 and cleared by software. 0: Meaningless 1: Failed to transmit
6:4	Reserved		
7	ABREQFLG0	R/S	Mailbox 0 Abort Request Flag If there is no message waiting for transmitting in mailbox 0, this bit is ineffective. 0: The transmitting message of mailbox 0 is cleared, and this bit is cleared by hardware 1: Set this bit to 1 to abort the transmission request of mailbox 0
8	REQCFLG1	RC_W1	Mailbox 1 Request Completed Flag When the last request of mailbox 1 is transmitted or aborted, this bit is set to 1 by hardware; When receiving the transmission request, this bit is cleared by hardware, and written to 1 and cleared by software. 0: Being transmitted 1: Transmission completed
9	TXSUSFLG1	RC_W1	Mailbox 1 Transmission Success Flag When mailbox 1 attempts to transmit successfully, this bit is set to 1 by hardware; and written to 1 and cleared by software. 0: Last transmission attempt failed 1: Last transmission attempt succeeded
10	ARBLSTFLG1	RC_W1	Mailbox 1 Arbitration Lost Flag When the mailbox 1 loses arbitration, this bit is set to 1 by hardware; and written to 1 and cleared by software. 0: Meaningless 1: Lost
11	TXERRFLG1	RC_W1	Mailbox 1 Transmission Error Flag When mailbox 1 fails to transmit, this bit is set to 1 by hardware; and written to 1 and cleared by software. 0: Meaningless 1: Failed to transmit
14:12	Reserved		
15	ABREQFLG1	R/S	Mailbox 1 Abort Request Flag If there is no message waiting for transmitting in mailbox 1, this bit is ineffective. 0: The transmitting message of mailbox 1 is cleared, and this bit is cleared by hardware 1: Set this bit to 1 to abort the transmission request of mailbox 1
16	REQCFLG2	RC_W1	Mailbox 2 Request Completed Flag When the last transmission or abortion request of the mailbox 2 is completed, this bit is set to 1 by hardware; when receiving the transmission request, this bit is cleared by hardware; it is written to 1 or cleared by software. 0: Being transmitted 1: Transmission completed
17	TXSUSFLG2	RC_W1	Mailbox 2 Transmission Success Flag When mailbox 2 attempts to transmit successfully, this bit is set to 1 by hardware; and written to 1 and cleared by software. 0: Last transmission attempt failed 1: Last transmission attempt succeeded
18	ARBLSTFLG2	RC_W1	Mailbox 2 Arbitration Lost Flag When the mailbox 2 loses arbitration, this bit is set to 1 by hardware; and written to 1 and cleared by software. 0: Meaningless 1: Lost

Field	Name	R/W	Description
19	TXERRFLG2	RC_W1	Mailbox 2 Transmission Error Flag When mailbox 2 fails to transmit, this bit is set to 1 by hardware; and written to 1 and cleared by software. 0: Meaningless 1: Failed to transmit
22:20	Reserved		
23	ABREQFLG2	R/S	Mailbox 2 Abort Request Flag If there is no message waiting for transmitting in mailbox 2, this bit is ineffective. 0: The transmitting message of mailbox 2 is cleared, and this bit is cleared by hardware 1: Set this bit to 1 to abort the transmission request of mailbox 2
25:24	EMNUM[1:0]	R	Empty Mailbox Number This bit is applicable when there is empty mailbox. When all the transmitting mailboxes are empty, it means the number of the transmitting mailbox with the lowest priority; when the mailbox is not empty but not all empty, it means the number of next mailbox to be transmitted.
26	TXMEFLG0	R	Transmit Mailbox 0 Empty Flag When the transmitting mailbox 0 is empty, this bit is set to 1 by hardware. 0: There is message to be transmitted in mailbox 0 1: There is no message to be transmitted in mailbox 0
27	TXMEFLG1	R	Transmit Mailbox 1 Empty Flag When the transmitting mailbox 1 is empty, this bit is set to 1 by hardware. 0: There is message to be transmitted in mailbox 1 1: There is no message to be transmitted in mailbox 1
28	TXMEFLG2	R	Transmit Mailbox 2 Empty Flag When the transmitting mailbox 2 is empty, this bit is set to 1 by hardware. 0: There is message to be transmitted in mailbox 2 1: There is no message to be transmitted in mailbox 2
29	LOWESTP0	R	The Lowest Transmission Priority Flag For Mailbox 0 0: Meaningless 1: The priority of mailbox 0 is the lowest among those mailboxes waiting to 358chmitt358 messages Note: If there is only one mailbox waiting, LOWESTP[2:0] is cleared.
30	LOWESTP1	R	The Lowest Transmission Priority Flag For Mailbox 1 0: Meaningless 1: The priority of mailbox 1 is the lowest among those mailboxes waiting to 358chmitt358 messages
31	LOWESTP2	R	The Lowest Transmission Priority Flag For Mailbox 2 0: Meaningless 1: The priority of mailbox 2 is the lowest among those mailboxes waiting to 358chmitt358 messages

25.6.1.4 CAN receive FIFO 0 register (CAN_RXF0)

Offset address: 0x0C

Reset value: 0x00

Field	Name	R/W	Description
1:0	FMNUM0[1:0]	R	The number of Message in receive FIFO0 These bits are used to reflect the number of messages stored in current receive FIFO0. Every time a new message is received, add 1 to FMNUM0 bit; every time the mailbox message is released and outputted, subtract 1 from FMNUM0 bit.
2	Reserved		

Field	Name	R/W	Description
3	FFULLFLG0	RC_W1	Receive FIFO0 Full Flag When there are three messages in FIFO0, it means the FIFO0 has been full; this bit is set to 1 by hardware and written to 1 and cleared by software. 0: Not full 1: Full
4	FOVRFLG0	RC_W1	Receive FIFO 0 Overrun Flag When there are three messages in FIFO0 and then a new message is received, it means the FIFO0 overrun; this bit is set to 1 by hardware and written to 1 and cleared by software. 0: No overrun 1: Overrun is generated
5	RFOM0	R/S	Release Receive FIFO0 Output Mailbox to Receive Message This bit is set to 1 by hardware and cleared by software. If there is no message in FIFO, this bit is invalid. When FIFO contains more than two messages, the output mailbox must be first released to access the second message. 0: Meaningless 1: Release the output mailbox of receive FIFO0
31:6	Reserved		

25.6.1.5 CAN receive FIFO 1 register (CAN_RXF1)

Offset address: 0x10

Reset value: 0x00

Field	Name	R/W	Description
1:0	FMNUM1[1:0]	R	The number of Message in receive FIFO1 These bits are used to reflect the number of messages stored in current receive FIFO1. Every time a new message is received, add 1 to FMNUM1 bit; every time the mailbox message is released and outputted, subtract 1 from FMNUM1 bit.
2	Reserved		
3	FFULLFLG1	RC_W1	Receive FIFO0 Full Flag When there are three messages in FIFO1, it means the FIFO1 has been full; this bit is set to 1 by hardware and written to 1 and cleared by software. 0: Not full 1: Full
4	FOVRFLG1	RC_W1	Receive FIFO1 Overrun Flag When there are three messages in FIFO1 and then a new message is received, it means the FIFO1 overrun ; this bit is set to 1 by hardware and written to 1 and cleared by software. 0: No overrun 1: Overrun is generated
5	RFOM1	R/S	Release Receive FIFO1 Output Mailbox to Receive Message This bit is set to 1 by hardware and cleared by software. If there is no message in FIFO, this bit is invalid. When FIFO contains more than two messages, the output mailbox must be first released to access the second message. 0: Meaningless 1: Release the output mailbox of receive FIFO1
31:6	Reserved		

25.6.1.6 CAN interrupt enable register (CAN_INTEN)

Offset address: 0x14

Reset value: 0x0000 0000

Field	Name	R/W	Description
-------	------	-----	-------------

Field	Name	R/W	Description
0	TXMEIEN	R/W	Transmit Mailbox Empty Interrupt Enable When REQCFLGx bit is set to 1, it means transmission has been completed, and the transmitting mailbox is empty; if this bit is set to 1, an interrupt will be generated. 0: No interrupt 1: Interrupt generated
1	FMIEN0	R/W	Interrupt Enable When The Number Of FIFO0 Message Is Not 0 When FMNUM0[1:0] bit of FIFO 0 is not zero, it means that the number of messages in FIFO0 is not zero; if this bit is set to 1, an interrupt will be generated. 0: No interrupt 1: Interrupt generated
2	FFULLIEN0	R/W	FIFO0 Full Interrupt Enable When the FFULLFLG0 bit of FIFO0 is set to 1, it means that the message of FIFO0 is full; if this bit is set to 1, an interrupt will be generated. 0: No interrupt 1: Interrupt generated
3	FOVRIEN0	R/W	FIFO0 Overrun Interrupt Enable When the FOVRFLG0 bit of FIFO0 is set to 1, it means that the FIFO0 has been overloaded; if this bit is set to 1, an interrupt will be generated. 0: No interrupt 1: Interrupt generated
4	FMPIEN1	R/W	Interrupt Enable when the number of FIFO1 Message is not 0 When FMNUM1[1:0] bit of FIFO 1 is not zero, it means that the number of messages in FIFO1 is not zero; if this bit is set to 1, an interrupt will be generated. 0: No interrupt 1: Interrupt generated
5	FFULLIEN1	R/W	FIFO1 Full Interrupt Enable When the FFULLFLG1 bit of FIFO1 is set to 1, it means that the message of FIFO1 is full; if this bit is set to 1, an interrupt will be generated. 0: No interrupt 1: Interrupt generated
6	FOVRIEN1	R/W	FIFO1 Overrun Interrupt Enable When the FOVRFLG1 bit of FIFO1 is set to 1, it means that the FIFO1 has been overloaded; if this bit is set to 1, an interrupt will be generated. 0: No interrupt 1: Interrupt generated
7	Reserved		
8	ERRWIEN	R/W	Error Warning Interrupt Enable When ERRWFLG bit is set to 1, an error warning will occur; if this bit is set to 1, ERRIFLG shall be set and a warning error interrupt will be generated. 0: ERRIFLG bit is not set 1: ERRIFLG bit is set to 1
9	ERRPIEN	R/W	Error Passive Interrupt Enable When ERRPFLG bit is set to 1, a passive error will occur; if this bit is set to 1, ERRIFLG shall be set and a passive error interrupt will be generated. 0: ERRIFLG bit is not set 1: ERRIFLG bit is set to 1
10	BOFFIEN	R/W	Bus-Off Interrupt Enable When BOFFFLG bit is set to 1, bus-off will occur; if this bit is set to 1, ERRIFLG shall be set and an bus-off error interrupt will be generated. 0: ERRIFLG bit is not set 1: ERRIFLG bit is set to 1
11	LECIEN	R/W	Last Error Code Interrupt Enable When an error is detected and the hardware sets LERRC[2:0], the last error code is recorded. If this bit set to 1, the ERRIFLG is set to generate the last error interrupt. 0: ERRIFLG bit is not set 1: ERRIFLG bit is set to 1
14:12	Reserved		

Field	Name	R/W	Description
15	ERRIEN	R/W	Error interrupt Enable When the corresponding error state register is set to 1, if this bit is set to 1, an error interrupt will be generated. 0: No interrupt 1: Interrupt generated
16	WUPIEN	R/W	Wakeup Interrupt Enable When WUPINT bit is set to 1, if this bit is set to 1, a wake-up interrupt will be generated. 0: No interrupt 1: Interrupt generated
17	SLEEPIEN	R/W	Sleep Interrupt Enable When SLEEPIFLG bit is set to 1, if this bit is set to 1, a sleep interrupt will be generated. 0: No interrupt 1: Interrupt generated
31:18	Reserved		

25.6.1.7 CAN error state register (CAN_ERRSTS)

Offset address: 0x18

Reset value: 0x0000 0000

Field	Name	R/W	Description
0	ERRWFLG	R	Error Warning Occur Flag When the value of the receiving error counter or transmitting error counter ≥ 96 , this bit is set to 1 by hardware. 0: No error warning 1: Error warning occurred
1	ERRPFLG	R	Error Passive Occur Flag When the value of the receiving error counter or transmitting error counter ≥ 127 , this bit is set to 1 by hardware. 0: No passive error 1: Passive error occurred
2	BOFLG	R	Enter Bus-Off Flag When the value of the transmitting error counter TXERRCNT is greater than 255, CAN will enter the bus-off state and this bit is set to 1 by hardware. 0: CAN not in bus-off state 1: CAN in bus-off state
3	Reserved		
6:4	LERRC	R/W	Record Last Error Code When the error on CAN bus is detected, it is set by hardware according to the error category; when the message is transmitted or received correctly, this bit is cleared by hardware. 000: No error 001: Bit stuffing error 010: Form (Form) error 011: Acknowledgment (ACK) error 100: Recessive bit error 101: Dominant bit error 110: CRC error 111: Set by software
15:7	Reserved		
23:16	TXERRCNT	R	Least Significant Byte Of The 9-Bit Transmit Error Counter The counter is implemented according to the transmission part of fault definition mechanism of CAN protocol.
31:24	RXERRCNT	R	Receive Error Counter The receiving error counter is implemented according to the receiving part of fault definition mechanism of CAN protocol. When receiving error occurs, according to the condition of error, add 1 or 8 to the counter, and

Field	Name	R/W	Description
			subtract 1 after receiving successfully. When the value of the counter is greater than 127, set the counter value to 120.

25.6.1.8 CAN bit timing register (CAN_BITTIM)

Offset address: 0x1C

Reset value: 0x0123 0000

Field	Name	R/W	Description
9:0	BRPSC	R/W	Baud Rate Prescaler Factor Setup Time cell $tq = (BRPSC+1) \times tPCLK$
15:10	Reserved		
19:16	TIMSEG1	R/W	Time Segment 1 Setup Time occupied by time period 1 $tBS1 = tCAN \times (TIMSEG1+1)$.
22:20	TIMSEG2	R/W	Time Segment 2 Setup Time occupied by time period 2 $tBS2 = tCAN \times (TIMSEG2+1)$.
23	Reserved		
25:24	RSYNJW	R/W	Resynchronization Jump Width Time that CAN hardware can extend or shorten in this bit $tRJW = tCAN \times (RSYNJW+1)$.
29:26	Reserved		
30	LBKMEN	R/W	Loop Back Mode Enable 0: Disable 1: Enable
31	SILMEN	R/W	Silent Mode Enable 0: Normal state 1: Silent mode

Note: When CAN is in initialization mode, this register can be accessed only by software

25.6.2 CAN Mailbox Register

This section describes the transmitting and receiving mailbox registers.

The transmitting and receiving mailboxes are almost the same except the following examples:

- FMIDX domain of CAN_RXDLENx register;
- The receiving mailbox is read-only;
- The transmitting mailbox is writable only when it is empty, and if the corresponding TXMEFLG bit of CAN_TXSTS register is 1, it means the transmitting mailbox is empty.

There are three transmitting mailboxes and two receiving mailboxes in total. Each receiving mailbox is FIFO with three levels of depth, and can only access the message that is received first in FIFO.

25.6.2.1 Transmit mailbox identifier register (CAN_TXMIDx) (x=0..2)

Offset address: 0x180, 0x190, 0x1A0

Reset value: 0xXXXX XXXX, X=undefined bit (except Bit 0, TXMREQ=0 after reset)

Field	Name	R/W	Description
0	TXMREQ	R/W	Transmit Mailbox Data Request 0: When the data in the mailbox is transmitted, the mailbox is empty and this bit is cleared by hardware 1: Software writes 1, to enable request to 363chmitt363 mailbox data
1	TXRFREQ	R/W	Transmit Remote Frame Request 0: Data frame 1: Remote frame
2	IDTYPESEL	R/W	Identifier Type Select 0: Standard identifier 1: Extended identifier
20:3	EXTID[17:0]	R/W	Extended Identifier Setup Low byte of extended identity label.
31:21	STDID[10:0]/EXTID[28:18]	R/W	Standard Identifier Or Extended Identifier According to the content of IDTYPESEL bit, these bits are standard identifier STDID[10:0] and high byte EXTID[28:18] of extended identifier.

Note: 1. When its mailbox is in the state of waiting for transmission, this register is write-protected

2. This register realizes transmission request control function (No. 0 bit) – the reset value is 0

25.6.2.2 Transmit mailbox data length register (CAN_TXDLENx) (x=0..2)

When the mailbox is not idle, all bits of this register are write-protected.

Offset address: 0x184, 0x194, 0x1A4

Reset value: 0xXXXX XXXX

Field	Name	R/W	Description
3:0	DLCODE	R/W	Transmit Data Length Code Setup
31:4	Reserved		

25.6.2.3 Transmit mailbox low-byte data register (CAN_TXMDLx) (x=0..2)

When the mailbox is not idle, all bits of this register are write-protected, and the message contains 0 to 7-byte data and starts from the byte 0.

Offset address: 0x188, 0x198, 0x1A8

Reset value: 0xXXXX XXXX

Field	Name	R/W	Description
7:0	DATABYTE0	R/W	Data Byte 0 of the Message
15:8	DATABYTE1	R/W	Data Byte 1 of the Message
23:16	DATABYTE2	R/W	Data Byte 2 of the Message
31:24	DATABYTE3	R/W	Data Byte 3 of the Message

25.6.2.4 Transmit mailbox high-byte data register (CAN_TXMDHx) (x=0..2)

When the mailbox is not idle, all bits of this register are write-protected.

Offset address: 0x18C, 0x19C, 0x1AC

Reset value: 0xXXXX XXXX, X=undefined bit

Field	Name	R/W	Description
7:0	DATABYTE4	R/W	Data Byte 4 of the Message

Field	Name	R/W	Description
15:8	DATABYTE5	R/W	Data Byte 5 of the Message
23:16	DATABYTE6	R/W	Data Byte 6 of the Message
31:24	DATABYTE7	R/W	Data Byte 7 of the Message

25.6.2.5 Receive FIFO mailbox identifier register (CAN_RXMIDx) (x=0..1)

Offset address: 0x1B0, 0x1C0

Reset value: 0xXXXX XXXX, X=undefined bit

Field	Name	R/W	Description
0	Reserved		
1	RFTXREQ	R	Remote Frame Transmission Request 0: Data frame 1: Remote frame
2	IDTYPESEL	R	Identifier Type Select 0: Stanard identifier 1: Extended identifier
20:3	EXTID[17:0]	R	Extended Identifier Setup Low byte of extended identifier.
31:21	STDID[10:0]/ EXTID[28:18]	R	Standard Identifier Or Extended Identifier According to the content of IDTYPESEL bit, these bits are standard identifier STDID[10:0] and high byte EXTID[28:18] of extended identifier.

Note: All receiving mailbox registers are read-only.

25.6.2.6 Receive FIFO mailbox data length register (CAN_RXDLENx) (x=0..1)

Offset address: 0x1B4, 0x1C4

Reset value: 0xXXXXXX XXXX

Field	Name	R/W	Description
3:0	DLCODE	R	Receive Data Length Code Setup This bit represents the data length in the frame; for remote frame, DLCODE is constantly 0.
7:4	Reserved		
15:8	FMIDX	R	Filter Match Index Setup
31:16	Reserved		

Note: All receiving mailbox registers are read-only.

25.6.2.7 Receive FIFO mailbox low-byte data register (CAN_RXMDLx) (x=0..1)

Offset address: 0x1B8, 0x1C8; the message contains 0 to 8-byte data, which starts from the byte 0.

Reset value: 0xXXXXXX XXXX

Field	Name	R/W	Description
7:0	DATABYTE0	R	Data Byte 0 of the Message
15:8	DATABYTE1	R	Data Byte 0 of the Message
23:16	DATABYTE2	R	Data Byte 0 of the Message

Field	Name	R/W	Description
31:24	DATABYTE3	R	Data Byte 0 of the Message

Note: All receiving mailbox registers are read-only.

25.6.2.8 Receive FIFO mailbox high-byte data register (CAN_RXMDHx) (x=0..1)

Offset address: 0x1BC, 0x1CC

Reset value: 0xXXXX XXXX, X=undefined bit

Field	Name	R/W	Description
7:0	DATABYTE4	R	Data Byte 0 of the Message
15:8	DATABYTE5	R	Data Byte 0 of the Message
23:16	DATABYTE6	R	Data Byte 0 of the Message
31:24	DATABYTE7	R	Data Byte 0 of the Message

Note: All receiving mailbox registers are read-only.

25.6.3 CAN Filter Register

25.6.3.1 CAN filter main control register (CAN_FCTRL)

Offset address: 0x200

Reset value: 0x2A1C 0E01

Field	Name	R/W	Description
0	FINITEN	R/W	Filter Init Mode Enable 0: Normal mode 1: Initialization mode
31:1	Reserved		

Note: The non-reserved bit of this register is completely controlled by software.

25.6.3.2 CAN filter mode configuration register (CAN_FCFG)

Offset address: 0x204

Reset value: 0x0000 0000

Field	Name	R/W	Description
13:0	FCFGx	R/W	Filterx Mode Configure The value of x is within 0-13. 0: Identifier mask bit mode 1: Identifier list mode
31:14	Reserved		

Note: Only when CAN_FCTRL (FINITEN =1) is set to make the filter in initialization mode, can this register be written.

25.6.3.3 CAN filter bit width configuration register (CAN_FSCFG)

Offset address: 0x20C

Reset value: 0x0000 0000

Field	Name	R/W	Description
13:0	FSCFGx	R/W	Filterx Scale Configure The value of x is within 0-13.

Field	Name	R/W	Description
			0: Two 16 bits 1: Single 32 bits
31:14	Reserved		

Note: Only when CAN_FCTRL (FINITEN =1) is set to make the filter in initialization mode, can this register be written.

25.6.3.4 CAN filter FIFO association register (CAN_FFASS)

Offset address: 0x214

Reset value: 0x0000 0000

Field	Name	R/W	Description
0	FFASS0	R/W	Configure Filter0 Associated with FIFO 0: The filter is 366chmitt366366d with FIFO0 1: The filter is 366chmitt366366d with FIFO1
1	FFASS1	R/W	Configure Filter1 Associated with FIFO Refer to FFASS0 for specific description.
2	FFASS2	R/W	Configure Filter2 Associated with FIFO Refer to FFASS0 for specific description.
3	FFASS3	R/W	Configure Filter3 Associated with FIFO Refer to FFASS0 for specific description.
4	FFASS4	R/W	Configure Filter4 Associated with FIFO Refer to FFASS0 for specific description.
5	FFASS5	R/W	Configure Filter5 Associated with FIFO Refer to FFASS0 for specific description.
6	FFASS6	R/W	Configure Filter6 Associated with FIFO Refer to FFASS0 for specific description.
7	FFASS7	R/W	Configure Filter7 Associated with FIFO Refer to FFASS0 for specific description.
8	FFASS8	R/W	Configure Filter8 Associated with FIFO Refer to FFASS0 for specific description.
9	FFASS9	R/W	Configure Filter9 Associated with FIFO Refer to FFASS0 for specific description.
10	FFASS10	R/W	Configure Filter10 Associated with FIFO Refer to FFASS0 for specific description.
11	FFASS11	R/W	Configure Filter11 Associated with FIFO Refer to FFASS0 for specific description.
12	FFASS12	R/W	Configure Filter12 Associated with FIFO Refer to FFASS0 for specific description.
13	FFASS13	R/W	Configure Filter13 Associated with FIFO Refer to FFASS0 for specific description.
31:14	Reserved		

Note: Only when CAN_FCTRL (FINITEN =1) is set to make the filter in initialization mode, can this register be written.

25.6.3.5 CAN filter activation register (CAN_FACT)

Offset address: 0x21C

Reset value: 0x0000 0000

Field	Name	R/W	Description
-------	------	-----	-------------

Field	Name	R/W	Description
0	FACT0	R/W	Filter0 Active 0: Disable 1: Active
1	FACT1	R/W	Filter1 Active Refer to FACT0 for specific description.
2	FACT2	R/W	Filter3 Active Refer to FACT0 for specific description.
3	FACT3	R/W	Filte3 Active Refer to FACT0 for specific description.
4	FACT4	R/W	Filter4 Active Refer to FACT0 for specific description.
5	FACT5	R/W	Filter5 Active Refer to FACT0 for specific description.
6	FACT6	R/W	Filte6 Active Refer to FACT0 for specific description.
7	FACT7	R/W	Filter7 Active Refer to FACT0 for specific description.
8	FACT8	R/W	Filter8 Active Refer to FACT0 for specific description.
9	FACT9	R/W	Filter9 Active Refer to FACT0 for specific description.
10	FACT10	R/W	Filter10 Active Refer to FACT0 for specific description.
11	FACT11	R/W	Filter11 Active Refer to FACT0 for specific description.
12	FACT12	R/W	Filter12 Active Refer to FACT0 for specific description.
13	FACT13	R/W	Filter13 Active Refer to FACT0 for specific description.
31:14	Reserved		

25.6.3.6 Register x of CAN filter group x (CAN_FiBANKx) (i = 0..13; x=1..2)

Offset address: 0x240..0x2AC

Reset value: 0xXXXX XXXX

Field	Name	R/W	Description
31:0	FBIT[31:0]	R/W	Filter Bits Setup Identifier list mode: 0: FBITx bit is dominant bit 1: FBITx bit is recessive bit Identifier mask bit mode: 0: FBITx is not used for comparison 1: FBITx must match Note: The value of x is 0~31, indicating the bit number of FBIT.

Note: There are 14 sets of filters in product: i=0..13. Each set of filters consists of two 32-bit registers and CAN_FIBANK[2:1]. The corresponding filter registers can be modified only when the corresponding FACTx bit of CAN_FACT register is cleared or the FINITEN bit of CAN_FCTRL register is 1.

26 Full-speed USB Device (USB)

26.1 Introduction

The peripheral meets the protocol standards and technical specifications of full-speed USB2.0 interface device, and realizes the interface docking between USB bus and APB1 bus. At the same time, the peripheral also has the functions of configurable up to 8 endpoints, synchronous transmission and endpoint double buffering mechanism, CRC check, USB suspension/restoration operation and frame lock clock pulse generation.

26.2 USB Functional Description

USB module realizes the communication interface function between the MCU and the PC which conform to USB2.0 interface protocol. In the process of realizing this function, a shared private data buffer directly accessible to USB peripheral is used. The size of this data buffer is determined by the number of configured endpoints and the maximum data packet size of different endpoints. Up to 8 bidirectional or 16 one-way endpoints can be used. Each endpoint can use 512 bytes at most. The format of data frame for USB and PC communication is completed by hardware.

Different endpoints need to have an independent buffer description block, which is used to describe the buffer address, size and byte length of the transmitted data of the endpoint. By responding to the USB interrupt, and judging the setting of the endpoint state register in the interrupt, the chip core enters different interrupt processing sub-functions, to process the services that the endpoint needs, and transmit corresponding types of data.

26.3 Register Address Mapping

Table 91 USB Register Address Mapping

Register name	Description	Offset address
USB_CTRL	USB control register	0x40
USB_INTSTS	USB interrupt state register	0x44
USB_FRANUM	USB frame state register	0x48
USB_ADDR	USB device address register	0x4C
USB_BUFFTBL	USB packet buffer description table address register	0x50
USB_LPMCTRLSTS	LPM control state register	0x54
USB_BCD	Battery charging detector	0x58
USB_EPn(n=[0...7])	USB endpoint n register	From 0x00 to 0x1C
USB_TXADDRn	Transmit buffer address register n	[USB_BUFFTBL]+n×16

Register name	Description	Offset address
USBD_TXCNTn	Transmit data byte number register n	[USBD_BUFFTB]+n×16+4
USBD_RXADDRn	Receive buffer address register n	[USBD_BUFFTB]+n×16+8
USBD_RXCNTn	Receive data byte number register n	[USBD_BUFFTB]+n×16+12

26.4 USBD Register Functional Description

The registers of USBD module have the following three categories:

- (1) General-purpose register: Interrupt register and control register;
- (2) Endpoint register: Endpoint configuration register and state register;
- (3) Buffer description table register: Register used to determine the packet storage address.

The base address of the buffer description table registers is specified by USBD_BUFFTB register, and the base address of all other registers is the base address 0x4000 5C00 of USBD module. Since the APB1 bus is 32-bit addressable, the addresses of all 16-bit registers are aligned according to 32-bit word. The same address alignment method is also used for the packet buffer memory areas starting from 0x4000 6000.

26.4.1 General-purpose Register

It is used to define the working mode of USBD module, interrupt processing, device address and reading of current frame number.

26.4.1.1 USBD control register (USBD_CTRL)

Offset address: 0x40

Reset value: 0x0003

Field	Name	R/W	Description
0	FORRST	R/W	Force USBD Reset Reset USBD by force, and before it is cleared by software, USBS always remains in reset state. 0: Clear 1: Reset by force
1	PWRDOWN	R/W	Power Down This mode is used to thoroughly close the USBD module. When this bit is set to 1, the USBD module cannot be used. 0: Open 1: Closed
2	LPWREN	R/W	Lowpower Mode Enable After this mode is turned on, when USBD is suspended, the system clock will stop or decrease to a certain frequency, and other static power consumption will be turned off except for the power supply of external pull-up resistor. Any wake-up event of USBD can clear this bit. 0: Normal mode 1: Low-power mode
3	FORSUS	R/W	Force Suspend When there is no data communication on USBD bus for 3ms, SUSP interrupt will be triggered, then the software needs to set this bit to 1. 0: Invalid 1: Pend USBD by force

Field	Name	R/W	Description
4	WKUPREQ	R/W	Wakeup Request Transmitt the wake-up request to PC master. If this bit remains valid within 1ms to 15ms, the master will wake up the USB D. 0: Invalid 1: Valid
5	L1WKUPREQ	R/W	LPML1 Wakeup request Transmitt the LPML1 wake-up signal to PC master and it will be cleared by hardware 0: Invalid 1: Valid
6	Reserved		
7	L1STSREQIM	R/W	LPML1 state request interrupt mask 0: LPML1 state request is disabled 1: L1REQ interrupt is enabled
8	ESOFIEN	R/W	Expected Start of Frame Interrupt Enable 0: Disable 1: Enable
9	SOFIEN	R/W	Start of Frame Interrupt Enable 0: Disable 1: Enable
10	RSTIEN	R/W	USB D Reset Interrupt Enable 0: Disable 1: Enable
11	SUSIEN	R/W	Suspend Mode Interrupt Enable 0: Disable 1: Enable
12	WKUPIEN	R/W	Wakeup Interrupt Enable 0: Disable 1: Enable
13	ERRIEN	R/W	Error Interrupt Enable 0: Disable 1: Enable
14	PMAOUIEN	R/W	Packet Memory Area Over / Underrun Interrupt Enable 0: Disable 1: Enable
15	CTRIEN	R/W	Correct Transfer Interrupt Enable 0: Disable 1: Enable

26.4.1.2 USB D interrupt state register (USB D_INTSTS)

Offset address: 0x44

Reset value: 0x0000

The application program confirms the interrupt request event by reading the interrupt source state information of this register.

When an interrupt event occurs, the corresponding bit will be set by the hardware. If the corresponding bit in USB D_CTRL is also set, an interrupt will be generated. After the interrupt is executed, the corresponding state bit will be cleared. It should be noted that when multiple interrupt flags are set, only one interrupt is generated.

USB D module has two-way interrupt request sources: high priority and low priority. The former interrupt request cannot be masked, while the latter can be

masked. After identifying which endpoint the interrupt request is from, call the corresponding interrupt service program.

Each bit is described in detail below:

Field	Name	R/W	Description
3:0	EPID[3:0]	R	Endpoint Identifier The application program reads the processing sequence of interrupt request through software. The processing sequence is determined by the endpoint number (the smaller the endpoint number is, the higher the priority is). The priority is written by hardware.
4	DOT	R	Direction of Transaction The application program reads this bit through the software to learn the transmission direction of the pending interrupt, so as to access the corresponding operation of CTFT or CTFR bit in USBD_EPn, and this bit is written by hardware according to the transmission direction. The IN packet means that the data are transmitted from the USBD module to the PC master, while the OUT packet is the opposite. When the packet is pending, it means the data transmission is completed. 0: The CTFT bit of the corresponding endpoint is set, which means that an IN packet is pending. 1: The CTFR bit of the corresponding endpoint is set, which means that an OUT packet is pending. If the CTFT bit is set at the same time, it means that both OUT packet and IN packet are pending at the same time.
6:5	Reserved		
7	L1STSREQ	RC_W0	LPML1 state request When the LPM command entering L1 state is successfully received and confirmed, the hardware sets this bit. 0: Valid 1: Invalid
8	ESOFFLG	RC_W0	Expected Start of Frame Flag When the USBD module does not receive the expected SOF packet, it is set by hardware. 0: Clear 1: Failed to receive the expected SOF packet
9	SOFFLG	RC_W0	Start Of Frame Flag It indicates the start of a new USBD frame, and when the USBD module detects the SOF packet on the bus, it will be set by hardware. 0: Clear 1: SOF packet is detected
10	RSTREQ	RC_W0	USBD Reset Request The application program is readable and writable, only valid when writing 0, and set by hardware. 0: Clear 1: Reset signal is detected
11	SUSREQ	RC_W0	Suspend Mode Request It indicates a pending request from the USBD bus, which is set by hardware when there is no signal transmission on the USBD line for more than 3ms. 0: Clear 1: Pending interrupt occurred
12	WUPREQ	RC_W0	Wakeup Request If the USBD module is pending and detects a wake-up signal, it will be set by hardware. 0: Clear 1: Wake-up signal is detected
13	ERRFLG	RC_W0	Failure Of Transfer Flag When NANS (master answer timeout)/CRC/BST (bit stuffing error)/FVIO (frame format error) occurs, it is set by hardware. 0: Clear 1: Transmission error occurred

Field	Name	R/W	Description
14	PMOFLG	RC_W0	Packet Memory Overflow Flag When the request to access the USB D packet buffer is transmitted but the MCU does not respond for a long time, it will be set by hardware. 0: Clear 1: Packet buffer overrun occurred
15	CTFLG	R	Correct Transfer Flag This bit is set by hardware after the endpoint completes data transmission once correctly. 0: Meaningless 1: Data transmission is completed correctly

26.4.1.3 USB D frame state register (USB D_FRANUM)

Offset address: 0x48

Reset value: 0x0XXX; X means undefined value

Field	Name	R/W	Description
10:0	FRANUM[10:0]	R	Frame Sequence Number Record the 11-bit frame code of the latest SOF packet, and the serial number will automatically increase as the quantity of transmit frames of the master increases.
12:11	LSOFNUM[1:0]	R	Continuous Lost SOF Number Record the number of SOF packets lost in the start of consecutive frame, and this bit is cleared when the SOF packet is received again.
13	LOCK	R	Lock If USB D continuously detects two or more SOP packets, it will be set by hardware, then the frame counter will stop counting until the USB D is reset or the bus is pending.
14	RXDMSTS	R	Receive Data- line Status It indicates the state of USB D D- (Data minus) data line, and can detect whether the wake-up condition appears in pending state.
15	RXDPSTS	R	Receive Data+ Line Status It indicates the state of USB D D+ (Data plus) data line, and can detect whether the wake-up condition appears in pending state.

26.4.1.4 USB D device address register (USB D_ADDR)

Offset address: 0x4C

Reset value: 0x0000

Field	Name	R/W	Description
6:0	ADDR[6:0]	R/W	Device Address Record the address value assigned by USB D master for the device in the process of enumeration.
7	USB DEN	R/W	USB D Enable Enable USB D. 0: Disable 1: Enable
15:8	Reserved		

26.4.1.5 USB D packet buffer description table address register (USB D_BUFFTB)

Offset address: 0x50

Reset value: 0x0000

Field	Name	R/W	Description
2:0	Reserved		

Field	Name	R/W	Description
15:3	BUFFTB	R/W	Buffer Table Record the start address of the packet buffer description table.

26.4.1.6 LPM control state register (USBD_LPMCTRLSTS)

Offset address: 0x54

Reset value: 0x0000

Field	Name	R/W	Description
0	LPMEN	R/W	LPM Support Enable 0: Invalid 1: Enable
1	LPMACKEN	R/W	LPM Token Confirmation Enable 0: Valid LPM token will be NYET 1: Valid LPM token will be ACK
2	Reserved		
3	REMWAKE	R	bRemoteWake Value This bit includes the bRemoteWake value of the last confirmed LPM token received
7:4	BESL	R	BESL Value These bits include the BESL value of the last confirmed LPM token received
15:8	Reserved		

26.4.1.7 Battery charging detector (USBD_BCD)

Offset address: 0x58

Reset value: 0x0000

Field	Name	R/W	Description
0	BCDEN	R/W	Battery Charging Detector Enable 0: Close BCD and start normal USB operation 1: Enable BCD, then USB PHY is completely controlled by BCD and it cannot communicate normally.
1	DCDEN	R/W	Data Contact Detection Mode Enable This bit is set by software to convert BCD mode to DCD mode.
2	PDEN	R/W	Primary Detection Mode Enable This bit is set by software to convert BCD mode to PD mode.
3	SDEN	R/W	Secondary Detection Mode Enable This bit is set by software to convert BCD mode to SD mode.
4	DCDFLG	R	Data Contact Detection Status Flag 0: Data line contact is not detected 1: Data line contact is detected
5	PDFLG	R	Primary Detection Status Flag 0: BCD support is not detected 1: BCD support is detected
6	SDFLG	R	Secondary Detection Status Flag 0: CDP is detected 1: DCP is detected

Field	Name	R/W	Description
7	DMPUDFLG	R	DM Pull-up Detection Status Flag This bit only takes effect during partial discharge, and the result of comparison between DM voltage and V_{LGC} threshold is given. Normally, DM level should be below this threshold. On the contrary, it means that DM is pulled up externally. This may be caused by connecting to the PS2 port or some special chargers that do not follow the BCD specification. 0: Normal port is detected 1: PS2 port or special charger is detected
14:8	Reserved		
15	DPPUCTRL	R/W	DP Pull-up Control This bit is set by software to enable the embedded pull-up on the DP line. The connection with the master can be disconnected by clearing it by user software.

26.4.2 USBD endpoint Register

Each endpoint has corresponding USBD_EPn (n=0...7) registers to store various state information of the endpoint.

26.4.2.1 USBD endpoint n register (USB_EPn) (n=0...7)

Offset address: 0x00 to 0x1C

Reset value: 0x0000

When the endpoint register receives USBD bus reset or the FORRST of USBD_CTRL is set, except that CTFT and CTFR bits remain unchanged for data transmission, other bits will be reset.

Each bit is described in detail below:

Field	Name	R/W	Description
3:0	ADDR[3:0]	R/W	Endpoint Address Before an endpoint is enabled, the application program must set these four bits as an address.
5:4	TXSTS[1:0]	T	Status Bits for Transmission Transfers This bit is used to identify the current state of the endpoint, and the transmitting state code table indicates all states. The application program is readable and writable; write 0 and this bit is invalid; write 1 to flip this bit.
6	TXDTOG	T	Data Toggle for Transmission Transfers (1) For asynchronous endpoints, it is used to indicate the Toggle bit of the next data packet to be transmitted: 0: DATA0 1: DATA1 (2) For double-buffer endpoints, it can be used for packet buffer exchange. (3) For synchronous endpoints, as only DATA0 is transmitted, this bit is only used to support packet buffer exchange. The hardware sets the bit after receiving the data packet. The application program is readable and writable; write 0 and this bit is invalid; write 1 to flip this bit.
7	CTFT	RC_W0	Correct Transfer Flag for Transmission This bit is set by hardware after a correct IN packet is transmitted. 0: Clear this bit and it is meaningless to read out 1: IN packet is transmitted correctly. Writing is invalid The application program is readable and writable; write 0 and this bit is valid; write 1 and this bit is invalid.
8	KIND	R/W	Endpoint Kind Please refer to the definition table of special types of endpoints for specific definitions.

Field	Name	R/W	Description
10:9	TYPE	R/W	Endpoint Type Please refer to the definition table of endpoint types for specific definitions.
11	SETUP	R	Setup Transaction Completed (read-only) It indicates whether the packet that currently completes transmission is SETUP packet. After the USB module receives a correct SETUP packet, it is set by hardware. 0: No 1: Yes Note: This bit can be modified only when CTFR is 0, and cannot be modified when CTFR is 1.
13:12	RXSTS	T	Status Bits for Reception Transfers This bit is used to identify the current state of the endpoint, and the receiving state code table indicates all states. The application program is readable and writable; write 0 and this bit is invalid; write 1 to flip this bit.
14	RXDTOG	T	Data Toggle for Reception Transfers (1) For asynchronous endpoints, flag the Toggle bit of the next data packet that is expected to be received, and it is set by hardware: 0: DATA0 1: DATA1 (2) For control endpoint, after receiving the SETUP packet, it is cleared by hardware. (3) For double-buffer endpoints, it is used for the exchange of double buffers. (4) For synchronous endpoints, it is only used for the exchange of double buffers, without flipping. The application program is readable and writable; write 0 and this bit is invalid; write 1 to flip this bit.
15	CTFR	RC_W0	Correct Transfer Flag for Reception This bit is set by hardware after OUT or SETUP packet is received correctly. 0: Clear 1: Packet is received correctly The application program is readable and writable; write 0 and this bit is valid; write 1 and this bit is invalid.

Table 92 Transmit State Codes

TXSTS[1:0]	Description
00	DISABLED: All receiving requests are ignored by the endpoint.
01	STALL: The endpoint responds to all receive requests with STALL packet.
10	NAK: The endpoint responds to all receive requests with NAK packet.
11	VALID: The endpoint can be used for receiving.

Table 93 Endpoint Type Codes

TYPE[1:0]	Description
00	BULK: Bulk endpoint
01	CONTROL: Control endpoint
10	ISO: Synchronous endpoint
11	INTERRUPT: Interrupt endpoint

Table93 Definition of Special Types of Endpoints

TYPE[1:0]	Meaning
00(BULK)	DBL_BUF: Double-buffer endpoint
01(CONTROL)	STATUS_OUT
Other	Unused

Table 94 Receive State Codes

RXSTS[1:0]	Description
00	DISABLED: All transmitting requests are ignored by the endpoint.
01	STALL: The endpoint responds to all 376chmitt376 requests with STALL packet.
10	NAK: The endpoint responds to all 376chmitt376 requests with NAK packet.
11	VALID: The endpoint can be used for transmitting.

26.4.3 Buffer Register

The buffer description table is located in the packet buffer to configure the address and size of the packet buffer shared by the USB module and the MCU core.

26.4.3.1 Transmit buffer address register n (USB_TXADDRn) (n=0...7)

Offset address: [USB_BUFFTB]+n×8

Field	Name	R/W	Description
0			Reserved, must be 0.
15:1	ADDR	R/W	Transmission Buffer Address Record the starting address of the buffer where the data to be transmitted is located when the next IN packet is received.

Note: This address location is called USB_TXADDRn_0 under the condition of bidirectional buffer or synchronous endpoint.

If there are double buffers or synchronous endpoints in the output direction, this address location is used for USB_RXADDRn_0.

26.4.3.2 Transmit data byte number register n (USB_TXCNTn) (n=0...7)

Offset address: [USB_BUFFTB]+n×8+2

Field	Name	R/W	Description
9:0	CNT	R/W	Transmission Byte Count This bit records the data byte count to be transmitted when receiving next IN group.
15:10			Reserved

Note: This address location is called USB_TXCNTn_0 under the condition of bidirectional buffer or synchronous endpoint.

For outward double buffers or synchronous endpoints, this address location is used for USB_RXCNTn_0.

26.4.3.3 Receive buffer address register n (USB_RXADDRn) (n=0...7)

Offset address: [USB_BUFFTB]+n×8+4

Field	Name	R/W	Description
0			Reserved, must be 0.

Field	Name	R/W	Description
15:1	ADDR	R/W	Reception Buffer Address Record the starting address of the buffer used to save data when receiving the next OUT or SETUP packet.

If there are double buffers or synchronous endpoints in the output direction, this address location is called USBD_RXADDRn_1.

This address location is used for USBD_TXADDRn_1 under the condition of bidirectional buffer or synchronous endpoint.

26.4.3.4 Receive data byte number register n (USBD_RXCNTn) (n=0...7)

Offset address: [USBD_BUFFTB]+n×8+6

It is used to store two parameters that need to be used when receiving packets: the buffer size of receiving packets and the number of bytes actually received by USBD.

Field	Name	R/W	Description
9:0	CNT	R	Reception Byte Count It is written by the USBD module to record the actual number of bytes of the latest OUT or SETUP packet received by the endpoint.
14:10	BLKNUM	R/W	Number of Blocks Record the number of memory blocks allocated, which determines the size of the packet buffer.
15	BLKSIZE	R/W	Block Size Determine the size of memory block, which determines the buffer size. 0: 2 bytes 1: 32 bytes

Note: For outward double buffers or synchronous endpoints, this address location is called USBD_RXCNTn_1.

This address location is used for USBD_TXCNTn_1 under the condition of bidirectional buffer or synchronous endpoint.

Table 95 Definition of Packet Buffer Sizes

Value of BLKNUM[4:0]	When BLKSIZE=0 Size of packet buffer	Size of packet buffer when BLKSIZE=1
00000	Not allowed to use	32byte
00001	2 bytes	64 bytes
00010	4 bytes	96 bytes
00011	6 bytes	128 bytes
...
01111	30 bytes	512 bytes
10000	32byte	Reserved
10001	34 bytes	Reserved
10010	36 bytes	Reserved
...
11110	60 bytes	Reserved
11111	62 bytes	Reserved

27 HDMI-CEC Controller (HDMI-CEC)

27.1 Introduction

Consumer electronic controller (CEC) is part of high-definition multimedia interface (HDMI) standard. CEC provides an advanced control function between various audio products. CEC runs at a low speed with minimal processing and memory overhead.

27.2 Main Characteristics

Internally integrated HDMI-CEC consumer electronic controller, and by using the controller, users can control multiple HDMI connected devices.

- Low power consumption, integrated with 32kHz CEC controller
- The local address is configurable
- Arbitration mechanism and listening mode
- Standard, extended RX tolerance
- Three kinds of receiving errors; error generation can be configured
- Detection of multiple error states

27.3 Structure block diagram

Figure 135 CEC Structure Block Diagram

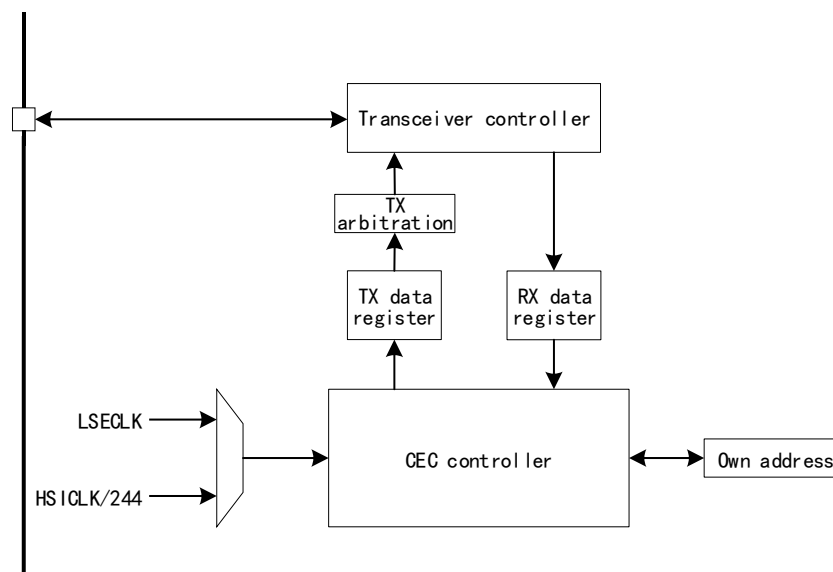

27.4 Main Functions

27.4.1 Bus Pin

CEC bus adopts single-bus protocol, the pins are configured in open-drain multiplexing mode, and 27kΩ resistance is pulled up externally, to achieve two-way data communication in the form of single line.

There are two states on the pin:

- 1=High impedance
- 0=Low impedance

27.4.2 Clock Source

CEC controller works at 32KHz frequency, with low power consumption and two clock sources:

- External LSECLK
- Internal HSICLK after 244 frequency division

27.4.3 Message Description

CEC bus is similar to a multi-master I2C bus. The data transmitter needs to transmit the source address and destination address to the bus. When the receiver detects that the target address is its own address, it will respond to the bus and realize the two-way communication through the source address of the transmitter.

Message type

CEC has three messages, namely header, opcode and operand. At the end of each message, there is the end of message bit EM and acknowledge bit ACK.

The header is used to transmit the source address and the destination address. When broadcasting equipment, it is only required to set the destination address to "0xF". The address is set by OACFG bit of register CEC_CFG.

Message structure

An message is 10 bits, and is transmitted to the bus as one frame of data. After receiving the message, the target receiver must respond, i.e. reply logic "0" to the bus.

Figure 1366 Blocks

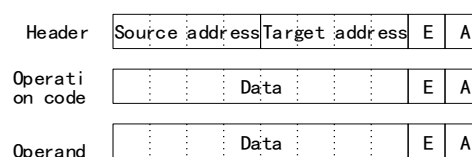

A complete communication consists of start bit, header, opcode and up to 15 message operands.

Figure 137 Message Structure

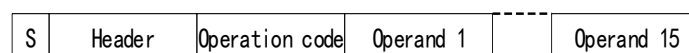

27.4.4 Arbitration Mechanism

At a certain moment, only one message transmitter is allowed on the bus, but in practical application, message conflict is inevitable. In order to avoid this problem, the consumer electronic controller adopts arbitration mechanism, and only after successful arbitration, can a transmitter really become the transmitter.

CEC releases the bus automatically after transmitting the message. If it needs to

transmit the message again, it must apply for the permission of the bus again. The time of releasing the bus is configured by SFTCFG bit of register CEC_CFG.

- When SFTCFG is equal to 0, CEC will calculate the time of releasing the bus consistent with HDMI-CEC standard by itself.
- When SFTCFG is not equal to 0, the time of releasing the bus is the time specified by the register.

Before transmitting a message, monitor the CEC bus. By configuring the pin to high impedance, read the state of the bus at this time. If it is “0”, it means that the arbitration is lost and the message cannot be transmitted. You need to be the message receiver. At this time the hardware will automatically set ARBLOSFLG, indicating loss of arbitration.

27.4.5 RX Tolerance

There are two modes of RX tolerance:

- Standard tolerance
- Extended tolerance

Configure RXTCFG bit of the register CEC_CFG, mainly a tolerance margin of the data receiver for the edge jump time of the start bit and the data bit.

27.4.6 Error Flag Bit

Error types include data bit error and message error.

Data bit error

- (1) Bit rising error RXBRERRFLG:

The message receiver recognizes the rising edge signal outside the data bit detection window. If GEBRERR bit is set, the hardware will set RXBRERRFLG. If the RXSBRERR bit is set, the receiver will stop receiving messages.

- (2) Short bit period error RXSBPEFLG:

When the falling edge of the data bit appears ahead of time, the hardware of message receiver will set RXSBPEFLG automatically.

- (3) Long bit period error RXLBPEFLG:

The falling edge of the data bit appears outside the detection window. By setting the GELBPERR bit, the hardware of the message receiver will automatically set RXLBPEFLG.

Message error

- (1) Transmission detection error TXERRFLG

In the process of CEC startup, if the bus is detected to be in a low-impedance state, a message transmission detection error will occur, the hardware will automatically set TXERRFLG, stop transmitting messages, and automatically clear the message start bit TXSM and stop bit TXEM.

- (2) Acknowledgment error

The acknowledgment error can occur in message transmitting mode and receiving mode. When no acknowledgment is received on the bus, an acknowledgment error will be generated to inform the user that the current message has not been acknowledged.

27.5 Register Address Mapping

Table 96 CEC Register Address Mapping

Register name	Description	Offset address
CEC_CTRL	Control register	0x00
CEC_CFG	Configuration register	0x04
CEC_TXDATA	Transmit data register	0x08
CEC_RXDATA	Receive data register	0x0C
CEC_STS	Interrupt and state register	0x10
CEC_INTEN	Interrupt enable register	0x14

27.6 Register Functional Description

27.6.1 Control register (CEC_CTRL)

Offset address: 0x00

Reset value: 0x0000 0000

Field	Name	R/W	Description
0	CECEN	R/W	CEC Enable This bit is set to 1 and cleared by software. 0: CEC is disabled, and all bits of this register are cleared 1: Enable
1	TXSM	R/S	TX Start Of Message TXSM bit is set to 1 by software to transmit the first byte of CEC message. If the CEC message contains only one byte, TXEM must set it to 1 before it is set to 1 by TXSM. After SFTCFG counting, the start bit will start effectively on CEC line. If TXSM is set to 1 during message receiving, transmission will start after receiving. When the last byte of the message is transmitted and TXEFLG=1, TXBUFLG=1, TXMACKFLG=1 and TXERRFLG=1, the bit will be cleared by hardware. This bit will also be cleared when CECEN=0. If arbitration fails, the transmission will be automatically retried (ARBLOSFLG=1). TXSM can be used as a status bit to inform the application program whether a transmission request is waiting or executing. The application program can abort the transmission request at any time by clearing the CECEN bit. 0: No CEC transmission 1: CEC transmission command Note: TXSM must be set to 1 when CECEN=1. When transmitting data to TXDATA, TXSM must be 1.
2	TXEM	R/S	TX End Of Message This bit commands to transmit the last byte of CEC message through software setting, and TXEM can be cleared by hardware in the same way as TXSM. 0: TXDATA transmits data bytes by EM=0 1: TXDATA transmits data bytes by EM=1 Note: TXEM must be set to 1 when CECEN=1 TXEM must be set before the transmitted data is written to TXDATA. When TXSM=0, set TXEM to 1 and the transmitted message will contain only

Field	Name	R/W	Description
			one byte (PING message).
31:3			Reserved

27.6.2 Configuration register (CEC_CFG)

Offset address: 0x04

Reset value: 0x0000 0000

Field	Name	R/W	Description
2:0	SFTCFG	R/W	<p>Signal Free Time Configure This bit is set by the software. When SFTCFG=0x0, the hardware will determine the number of waiting data bit cycles before transmission according to the transmission history. In other configurations, the SFT data bit cycle is determined by software. This bit configures the number of data bit cycles. 000: 2.5: ARBLOSFLG=1, TXERRFLG=1, TXBUFLG=1 or TXMACKFLG=1, namely, CECEN is the last bus starter which transmits unsuccessfully 4: CEC is new bus starter 6: TXEM=1, namely, CEC is the last bus starter transmitted successfully 001: 0.5 010: 1.5 011: 2.5 100: 3.5 101: 4.5 110: 5.5 111: 6.5</p>
3	RXTCFG	R/W	<p>RX Tolerance Configure 0: Standard tolerance Start bit: +/-200µs rising, +/-200µs falling Data bit: +/-200µs rising, +/-350µs falling 1: Extended tolerance Start bit: +/-400µs rising, +/-400µs falling Data bit: +/-300µs rising, +/-500µs falling</p>
4	RXSBRERR	R/W	<p>RX-Stop On Bit Rising Error Configure This bit indicates whether RXBREFLG detection stops CEC receiving message 0: Not stop; the data bits are sampled at 1.05ms 1: Stopped</p>
5	GEBRERR	R/W	<p>Generate Error-Bit On Bit Rising Error Enable This bit indicates whether error bit is generated when RXBRERRFLG is detected on CEC line 0: Error bit is not generated 1: Generate Note: When AEBGIB=0, even if GEBRERR=0, RXSBRERR=1 in the broadcasting, RXBRERRFLG detection will generate an error bit.</p>
6	GELBPERR	R/W	<p>Generate Error-Bit On Long Bit Period Error Enable This bit indicates whether error bit is generated when RXLBPEFLG is detected on CEC line 0: Not generated 1: Generate Note: If AEBGIB=0, even if, GELBPERR=0, LBPE detection in broadcasting will generate an error bit.</p>
7	AEBGIB	R/W	<p>Avoid Error-Bit Generation in Broadcast 0: BRE with RXSBRERR=1 and GEBRERR=0 in the broadcast message detects that an error bit is generated on CEC line; RXLBPEFLG with GELBPERR=0 in the broadcast message detects that an error bit is generated on CEC line. 1: Error bits are not generated in the same case. If listening mode is set, even if SBPE detects broadcast messages, no error bit will be generated</p>

Field	Name	R/W	Description
8	SFTOB	R/W	SFT Option Bit Configure 0: The SFT timer starts when TXSM is set by software 1: The SFT timer starts automatically when message transmitting/receiving is ended
15: 9	Reserved		
30:16	OACFG	R/W	Own Addresses Configure This bit is configured by software to select the destination logical address that must be considered in the receiving mode. CEC logical address of the given position identification when this bit is set. At the end of receiving of the header, compare the received destination address with the enabled address, and if the address matches, the received message will be acknowledged and received. In case that the address mismatches, the incoming message is received only when LMODSEL=1, and the acknowledged message will not be transmitted. The broadcast message is always received. For example: OACFG=0b000 0000 0010 0001 indicates that CEC receiving address is 0x0 and 0x5. Therefore, each message transmitted to either address will be received.
31	LMODSEL	R/W	Listen Mode Select 0: The broadcast message is always received. CEC peripherals only receive messages from their own address (OACFG). The messages transmitted to different addresses will be ignored. 1: CEC peripheral receives the message transmitted to its own address (OACFG) and gives affirmative acknowledgment. Messages transmitted to different addresses will be received, but do not interfere with the CEC bus: acknowledgment will not be transmitted.

27.6.3 TX data register (CEC_TXDATA)

Offset address: 0x08

Reset value: 0x0000 0000

Field	Name	R/W	Description
7:0	TXDATA	W	TX Data This bit includes the data bytes to be transmitted
31:8	Reserved		

27.6.4 RX data register (CEC_RXDATA)

Offset address: 0x0C

Reset value: 0x0000 0000

Field	Name	R/W	Description
7:0	RXDATA	R	RX Data This bit includes the last data byte received from CEC line
31:8	Reserved		

27.6.5 Interrupt and state register (CEC_STS)

Offset address: 0x10

Reset value: 0x0000 0000

Field	Name	R/W	Description
0	RXBREFLG	RC_W1	RX-Byte Received Flag This bit can be written to 1 and cleared by software. This bit can be set to 1 by hardware to inform the application program to receive new bytes from CEC line and store them in RXDATA buffer.

Field	Name	R/W	Description
1	RXEFLG	RC_W1	<p>RX End Flag This bit can be written to 1 and cleared by software. This bit can be set to 1 by hardware to inform the application program that the last byte of CEC message is received and stored to RXDATA buffer. This bit and RXBREFLAG are set at the same time.</p>
2	RXOVRFLG	RC_W1	<p>RX-Overflow Flag This bit can be written to 1 and cleared by software. When a new byte is received on the CEC line and stored in RXDATA, if RXBRERRFLG is not cleared, this bit is set by hardware 1. This bit will terminate the message receiving, so that no confirmation will be transmitted. Under the condition of broadcasting, transmit a negative response.</p>
3	RXBRERRFLG	RC_W1	<p>RX-Bit Rising Error Flag This bit can be written to 1 and cleared by software. When a bit rising error is detected in the data bit waveform, this bit will be set to 1 by hardware. This bit will also be set to 1 on the rising edge of the error bit, or when the rising edge reaches the specified maximum RXTCFG tolerance during the duration of the rising edge. When RXSBRERR=1, a bit rising error event will occur, and the system will stop receiving messages; when GEBRERR=1, a rising error event will occur and a bit error will be generated on the CEC line.</p>
4	RXSBPEFLG	RC_W1	<p>RX-Short Bit Period Error Flag This bit can be written to 1 and cleared by software. When a short bit period error is detected in the data bit waveform, this bit will be set to 1. When the expected falling edge occurs, this bit will be set to 1. An error bit will be generated when RXSBPEFLG is detected on CEC line</p>
5	RXLBPEFLG	RC_W1	<p>RX-Long Bit Period Error Flag This bit can be written to 1 and cleared by software. When a long-bit period error is detected in the data bit waveform, this bit is set to 1 by hardware. When the falling edge reaches the maximum bit extended tolerance specified by RXTCFG, this bit is set to 1 by hardware. Receiving of CEC message will be stopped due to RXLBPEFLG event. If GELBPERR=1, a bit error will be generated on CEC line due to RXLBPEFLG event. During broadcasting, a bit error will be generated even if GELBPERR=0.</p>
6	RXMACKFLG	RC_W1	<p>Rx-Missing Acknowledge Flag This bit can be written to 1 and cleared by software. In the receiving mode, the bit is set to 1 by hardware to inform the application program that no acknowledgment is received on the CEC line. This bit is only applicable to broadcast messages. In listening mode, the destination address is not enabled in OACFG. This bit terminates receiving the message.</p>
7	ARBLOSFLG	RC_W1	<p>Arbitration Lost Flag This bit can be written to 1 and cleared by software. This bit is set to 1 by hardware to inform the application program that due to the arbitration loss event after the TXSM command, the CEC device switches to the receiving mode. This bit may be started earlier by competing CEC device, or be started at the same time due to the changed frame priority. After the arbitration loss event, the TXSM bit will be held for the next transmission attempt.</p>

Field	Name	R/W	Description
8	TXBREFLG	RC_W1	TX-Byte Request Flag This bit can be written to 1 and cleared by software. This bit is set to 1 by hardware to inform the application program that the next data to be transmitted must be written to TXDATA. TXBR is set to 1 when the 4 bit of the currently transmitted byte is transmitted. Before an underrun error (TXBUFLG) occurs, the application program must write the next byte to TXDATA within six nominal data bit periods.
9	TXEFLG	RC_W1	TX End Flag This bit can be written as 1 and cleared by software and be set to 1 by hardware to inform the application program that the last byte of CEC 385chmitt is transmitted successfully. When this bit is set to 1, TXSM and TXEM control bits will be cleared.
10	TXBUFLG	RC_W1	TX-Buffer Underrun Flag This bit can be written to 1 and cleared by software. In transmitting mode, if the application program does not load TXDATA in time before the next byte is transmitted, the bit will be set to 1 by hardware. This bit can terminate the message transmitting and clear TXSM and TXEM control bits.
11	TXERRFLG	RC_W1	Transmission Error Flag This bit can be cleared and written as 1 by software. In the transmitting mode, if the CEC starter detects low impedance on the CEC line, this bit will be set to 1 by hardware. This bit can terminate the message transmitting and clear TXSM and TXEM control bits.
12	TXMACKFLG	RC_W1	TX-Missing Acknowledge Error Flag This bit can be written as 1 and cleared by software. In the transmitting mode, the bit is set to 1 by hardware to inform the application program that no acknowledgment is received. In broadcast transmission, the bit will inform the application program that a negative acknowledgment is received. This bit interrupts the transmitting of messages and clears TXSM and TXEM control bits.
31:13	Reserved		

27.6.6 Interrupt enable register (CEC_INTEN)

Offset address: 0x14

Reset value: 0x0000 0000

Field	Name	R/W	Description
0	RXBREIEN	R/W	RX-Byte Received Interrupt Enable 0: Disable 1: Enable
1	RXEIEN	R/W	End Of Reception Interrupt Flag Enable 0: Disable 1: Enable
2	RXOVRIEN	R/W	RX-Buffer Overrun Interrupt Flag Enable 0: Disable 1: Enable
3	RXBRERRIEN	R/W	RX Bit Rising Error Interrupt Flag Enable 0: Disable 1: Enable
4	RXSBPEIEN	R/W	RX Short Bit Period Error Interrupt Flag Enable 0: Disable 1: Enable

Field	Name	R/W	Description
5	RXLBPEIEN	R/W	RX Long Bit Period Error Interrupt Flag Enable 0: Disable 1: Enable
6	RXMACKIEN	R/W	RX-Missing Acknowledge Error Interrupt Flag Enable 0: Disable 1: Enable
7	ARBLOSIEN	R/W	Arbitration Lost Interrupt Flag Enable 0: Disable 1: Enable
8	TXBREIEN	R/W	TX-Byte Request Interrupt Flag Enable 0: Disable 1: Enable
9	TXIEN	R/W	TX-End Of Message Interrupt Flag Enable 0: Disable 1: Enable
10	TXBUIEN	R/W	TX-Underrun Interrupt Flag Enable 0: Disable 1: Enable
11	TXERRIEN	R/W	TX-Error Interrupt Flag Enable 0: Disable 1: Enable
12	TXMACKIEN	R/W	TX-Missing Acknowledge Flag Error Interrupt Enable 0: Disable 1: Enable
31:13	Reserved		

28 Analog-to-digital Converter (ADC)

28.1 Introduction

ADC with 12-bit precision and 19 channels, including 16 external channels and 2 internal channels, and there are single, continuous or intermittent A/D conversion modes for each channel. ADC conversion results can be left-aligned or right-aligned and stored in 16-bit data register.

28.2 Main Characteristics

- (1) ADC power supply requirements: From 2.4V to 3.6V
- (2) ADC input range: $V_{SSA} \leq V_{IN} \leq V_{DDA}$
- (3) Conversion mode
 - Single conversion mode
 - Continuous conversion mode
 - Discontinuous mode
- (4) Analog input channel category
 - External GPIO input channel
 - One internal reference voltage (V_{REFINT}) input channel
 - One V_{BAT} pin voltage input channel
- (5) High performance
 - 12-bit, 10-bit, 8-bit or 6-bit configurable resolution.
 - Self-calibration
 - Programmable sampling time
 - Data alignment
 - DMA supported
- (6) Low power
 - Low-power operation reduces PLCK frequency and maintains optimum ADC performance
 - Automatic delay mode: Run in PCLK low speed, to prevent ADC over-limit
 - Automatic shutdown mode: ADC can power off automatically at other times except during conversion period
- (7) Interrupt
 - End of conversion interrupt
 - End of sequence conversion interrupt
 - End of sampling phase interrupt
 - ADC ready interrupt
 - Overshoot interrupt
 - Analog watchdog state reset interrupt
- (8) Trigger mode
 - External pin signal trigger
 - Internal signal trigger generated by on-chip timer

28.3 ADC Functional Description

28.3.1 ADC Pin and Internal Signal

Table 97 ADC Internal Signal

Name	Instruction	Signal type
TMRx_TRG	Internal information from timer	Input
V _{REFINT}	Output of internal reference voltage	Input
V _{BAT}	V _{BAT} pin input voltage	Input

Table 98 ADC Pins

Name	Instruction	Signal type
V _{DDA}	Analog power supply, positive ADC reference voltage, V _{DDA} ≥ V _{DD}	Input, analog power supply
V _{SSA}	Analog ground, V _{SSA} = V _{SS}	Input, analog power ground
ADC_IN[15:0]	16 channels analog inputs	Analog input signal

28.3.2 Calibration

The function of calibration is to eliminate the offset error of A/D conversion of each chip, so calibration should be conducted before A/D conversion, and ADC module cannot be used during calibration.

Calibration configuration process:

- Configure ADCEN bit of register ADC_CTRL to 0, and disable ADC
- Configure CAL bit of register ADC_CTRL to 1, and enable calibration
- After calibration is completed, CAL bit is automatically cleared by hardware
- The calibration factor is read in CDATA[6:0] bit of register ADC_DATA

28.3.3 ADC Conversion Mode

28.3.3.1 Single conversion mode

In this mode, for single channel, only one conversion is performed for this channel, and for multiple channels, only one conversion is performed for this group of channels .

When CMODESEL bit of configuration register ADC_CFG1 is 0, ADC is set to single conversion mode; ADC conversion can be enabled by setting STARTCEN bit of configuration register ADC_CTRL to 1 by software or by trigger event of hardware.

After the conversion of each channel, the converted data will be stored in the 16-bit ADC_DATA register, EOCFLG bit will be set to 1, and if EOCIEN bit is set to 1, an interrupt will be generated. After the channel sequence conversion, EOSEQFLG bit will be set to 1, and if EOSEQIEN bit is set to 1, an interrupt will be generated.

28.3.3.2 Continuous conversion mode

In this mode, for single channel, continuous conversion is only conducted for this channel; for multiple channels, continuous conversion is only conducted for this group of channel.

When CMODESEL bit of register ADC_CFG1 is configured to 1, ADC is set to continuous conversion mode; configure STARTCEN bit of register ADC_CTRL to 1 by software or trigger the event by hardware to enable ADC conversion.

After the conversion of each channel, the converted data will be stored in the 16-bit ADC_DATA register, EOCFLG bit will be set to 1, and if EOCIEN bit is set to 1, an interrupt will be generated. After the channel sequence conversion, EOSEQFLG bit will be set to 1, and if EOSEQIEN bit is set to 1, an interrupt will be generated.

28.3.3.3 Discontinuous mode

Configure DISCEN bit of register ADC_CFG1 to 1, and set ADC to discontinuous mode; enable ADC conversion by software or by trigger event of hardware. In this mode, only one channel of one sequence is converted at a time. If DISCEN bit is cleared, all channels of one sequence will be converted at a time.

Example:

- DISCEN bit is set to 1, and the channel sequence is 0, 1, 5
 - 1st trigger, Channel 0 is converted and generates an EOCFLG event
 - 2nd trigger, Channel 1 is converted and generates an EOCFLG event
 - 3rd trigger, Channel 5 is converted and generates an EOCFLG event
- DISCEN bit is set to 0, and the channel sequence is 0, 1, 5
 - 1st trigger, Channels 0, 1 and 5 are converted in sequence. After the conversion of each channel, an EOCFLG event will be generated. After the conversion of the whole sequence, an EOSEQFLG event will be generated

28.3.4 ADC Channel Classification

28.3.4.1 Analog input channel introduced by GPIO pin

In total 16 channels are connected to ADC_IN0...ADC_IN15.

28.3.4.2 Internal analog input channel

Internal reference voltage V_{REFINT}

- (1) The internal reference voltage is used to provide a stable voltage output for ADC
- (2) Internal reference voltage V_{REFINT} is used to select ADC1_IN17 input channel

V_{BAT} pin voltage

V_{BAT} pin input voltage selects ADC1_IN18 input channel.

28.3.5 External Trigger and Trigger Polarity

The external trigger event can be selected by EXTTRGSEL bit of configuration register ADC_CFG1.

Table 99 External Trigger

Trigger source	EXTTRGSEL	Trigger type
TMR1_TRGO	000	Internal signal generated by on-chip timer
TMR1_CC4	001	
TMR3_TRGO	010	
TMR1_TRGO	011	

Trigger source	EXTTRGSEL	Trigger type
TMR15_TRGO	100	
Reserved	101	
Reserved	110	
Reserved	111	External pin

When the bit `EXTPOLSEL#` "0b00" for the register `ADC_CFG1`, the external event can trigger conversion on its selected polarity.

Table 100 Configuration Trigger Polarity

EXTPOLSEL	Source
00	Detection of disabled trigger
01	Detection on rising edge
10	Detection on falling edge
11	Detection on both rising edge and falling edge

28.3.6 Data Register

The data can be left-aligned or right-aligned, which is determined by `DALIGCFG` bit of configuration register `ADC_CFG1`. ADC conversion results can be left-aligned or right-aligned and stored in 16-bit data register.

28.3.7 Programmable Conversion Resolution

Reducing the resolution can improve the conversion time and 12, 10, 8 or 6-bit modes can be selected by `DATARESCFG[1:0]` bit of configuration register `ADC_CFG1`.

Table 101 Conversion Time of tSTAR Related to Conversion Resolution

DATARESCFG bit	t _{SAR}	t _{SAR} (ns)@f _{ADC} =14MHz	t _{SMPL} (min)	t _{ADC}	t _{ADC} (μs)@f _{ADC} =14MHz
6	7.5	535ns	1.5	9	643ns
8	9.5	678ns	1.5	11	785ns
10	11.5	821ns	1.5	13	928ns
12	12.5	893ns	1.5	14	1000ns

28.3.8 Interrupt

Table 102 ADC Interrupt

Interrupt event	Event flag	Enable control
End of conversion	EOCFLG	EOCIEN
End of sequence conversion	EOSEQFLG	EOSEQIEN
End of sampling phase	EOSMPFLG	EOSMPIEN

Interrupt event	Event flag	Enable control
ADC ready	ADCRDYFLG	ADCRDYIEN
Overrun	OVREFLG	OVRIEN
Analog watchdog state reset	AWDFLG	AWDIEN

28.3.9 ADC Overrun

ADC overrun means when the converted data is not read by DMA or CPU on time, another converted data will take effect.

When EOCFLG bit is 1 but another new conversion has been completed, an overrun event will occur, and OVREFLG bit of register ADC_STS will be set to 1; if OVRIEN bit is set to 1, an overrun interrupt will be generated.

It is determined by OVRMAG bit of configuration register ADC_CFG1 that the data in the ADC data register are held or covered when an overrun event occurs:

- OVRMAG is 0: When an overrun event is detected, old data will be held in ADC_DATA register
- OVRMAG is set to 1: When an overrun event is detected, ADC_DATA register will cover the data by the last converted data

28.3.10 Data Conversion Management

28.3.10.1 No DMA participating in data conversion management

The software controls data conversion. Every time the conversion is completed, EOCFLG will be set to 1, and the conversion results will be read from ADC_DATA register. Then OVRMAG bit in ADC_CFG1 register should be 0.

28.3.10.2 No DMA and overrun participating in data conversion management

When one or more channels are converted and each conversion result does not need to be read, OVRMAG bit will be set to 1, overrun event cannot prevent ADC conversion and the register ADC_Data only saves the last converted data.

28.3.10.3 DMA management of data conversion

DMA transmission can be used to transmit the conversion results from the data register to the memory in time to prevent loss of the conversion results in the ADC_DATA register.

DMA can be enabled by setting DMAEN bit of the register ADC_CFG1 to 1. After each conversion, a DMA request will be generated to transmit the converted data of data register to the memory.

When DMA fails to respond to DMA request in time, an overrun event will be generated, and OVREFLG bit will be set to 1. After that, ADC will not generate DMA request and DMA will not transmit new conversion results. DMA will start to work again when OVREFLG bit is cleared.

DMA mode is selected by DMACFG bit of configuration register ADC_CFG1:

- When DMACFG is 0, DMA is in single mode
 - DMA programming is used to transmit the fixed-length data
 - In this mode, ADC will generate DMA request every time it converts data effectively. When ADC conversion is restarted, ADC will stop generating DMA request
- When DMACFG is set to 1, DMA is in circular mode
 - DMA programming is in circular mode or double-buffer mode
 - In this mode, when ADC conversion is started again and the converted data is valid, a DMA request will be generated

28.3.11 Low-power Characteristics

28.3.11.1 Automatic delay conversion mode

This mode is used to simplify the software and optimize the application program performance during low-speed running, and ADC overrun may occur easily.

Set WAITCEN of configuration register ADC_CFG1 to 1, enable the automatic delay conversion mode, and new ADC conversion will start only after the data in ADC data register are read, which is a method of adaptive ADC speed and adaptive system reading ADC data speed.

28.3.11.2 Automatic shutdown mode

This mode can greatly reduce the application power consumption, and is suitable for applications with relatively few conversions or long conversion request time interval. Automatic shutdown mode can be used in combination with automatic delay conversion mode in low-frequency application.

Automatic shutdown mode can be enabled by setting AOEN bit of configuration register ADC_CFG1 to 1. When AOEN bit is set to 1 and there is no ADC conversion, it will be powered off automatically, and when the conversion is started, ADC will be waken up automatically.

28.4 Register Address Mapping

Table 103 ADC Register Address Mapping Table

Register name	Description	Offset address
ADC_STS	ADC state register	0x00
ADC_IEN	ADC interrupt enable register	0x04
ADC_CTRL	ADC control register	0x08
ADC_CFG1	ADC configuration register 1	0x0C
ADC_CFG2	ADC configuration register 2	0x10
ADC_SMPTIM	ADC sampling time register	0x14
ADC_AWDT	ADC watchdog threshold register	0x20
ADC_CHSEL	ADC channel selection register	0x28
ADC_DATA	ADC data register	0x40
ADC_CCFG	ADC common configuration register	0x308

28.5 Register Functional Description

28.5.1 ADC state register

Offset address: 0x00

Reset value: 0x0000 0000

Field	Name	R/W	Description
-------	------	-----	-------------

Field	Name	R/W	Description
0	ADCRDYFLG	RC_W1	ADC Ready Flag 0: ADC not ready 1: ADC has been ready to start conversion
1	EOSMPFLG	RC_W1	End of Sampling Flag This bit is set to 1 by hardware and cleared by software 0: Not in the phase of end of sampling 1: Reach the condition for end of sampling phase
2	EOCFLG	RC_W1	End of Conversion Flag This bit is set to 1 by hardware and cleared by software 0: Conversion does not end 1: Conversion ends
3	EOSEQFLG	RC_W1	End of Sequence Flag This bit is set to 1 by hardware and cleared by software 0: Sequence conversion not completed 1: Sequence conversion completed
4	OVREFLG	RC_W1	ADC Overrun Event Flag This bit is set to 1 by hardware and cleared by software 0: No overrun event 1: Overrun event occurred
6:5	Reserved		
7	AWDFLG	RC_W1	Analog Watchdog Flag This bit is set to 1 by hardware and cleared by software, indicating whether an analog watchdog event occurs. 0: Not occur 1: Occurred
31:8	Reserved		

28.5.2 ADC interrupt enable register (ADC_IEN)

Offset address: 0x04

Reset value: 0x0000 0000

Field	Name	R/W	Description
0	ADCRDYIEN	R/W	ADC Ready Interrupt Enable 0: Disable 1: Enable
1	EOSMPIEN	R/W	End of Sampling Flag Interrupt Enable 0: Disable 1: Enable
2	EOCIEN	R/W	End of Conversion Interrupt Enable 0: Disable 1: Enable
3	EOSEQIEN	R/W	End of Conversion Sequence Interrupt Enable 0: Disable 1: Enable
4	OVRIEN	R/W	Overrun Interrupt Enable 0: Disable 1: Enable
6:5	Reserved		

Field	Name	R/W	Description
7	AWDIEN	R/W	Analog Watchdog Interrupt Enable 0: Disable 1: Enable
31:8	Reserved		

Note: These bits can be rewritten only when STARTCEN=0.

28.5.3 ADC control register (ADC_CTRL)

Offset address: 0x08

Reset value: 0x0000 0000

Field	Name	R/W	Description
0	ADCEN	R/S	ADC Enable This bit is set to 1 by software and cleared by hardware. 0: ADC is disabled 1: ADC is enabled Note: ADCEN bit can be set by software only when all bits of ADC_CTRL register are 0.
1	ADCD	R/S	ADC Disable This bit is set to 1 by software and cleared by hardware. 0: Invalid 1: Disable ADC, and enter power-off mode Note: ADCD bit can be set by software only when ADCEN=1 and STARTCEN=0.
2	STARTCEN	R/S	ADC Start Conversion Enable This bit is set to 1 by software and cleared by hardware. 0: ADC conversion is disabled 1: Start ADC conversion Note: STARTCEN bit can be set by software only when ADCEN=1 and ADCD=0.
3	Reserved		
4	STOPCEN	R/S	ADC Stop Conversion Enable This bit is set to 1 by software and cleared by hardware. 0: Invalid 1: Stop ADC conversion Note: This bit can be set by software only when STARTCEN=1 and ADCD=0.
30:5	Reserved		
31	CAL	R/S	ADC Calibrate This bit is set to 1 by software and cleared by hardware. 0: Calibration is completed 1: Start calibration Note: CAL bit can be set by software only when ADC is disabled.

28.5.4 ADC configuration register 1 (ADC_CFG1)

Offset address: 0x0C

Reset value: 0x0000 0000

Field	Name	R/W	Description
0	DMAEN	R/W	DMA Enable 0: DMA is disabled 1: DMA is enabled
1	DMACFG	R/W	DMA Mode Configure This bit is valid only when DMAEN=1. 0: DMA single mode 1: DMA circular mode
2	SCANSEQDIR	R/W	Scan Sequence Direction Configure 0: Scan forward (from CHSEL0 to CHSEL16) 1: Scan backward (from CHSEL16 to CHSEL0)
4:3	DATARESCFG	R/W	Data Resolution Configure 00: 12 bits 01: 10 bits 10: 8 bits 11: 6 bits
5	DALIGCFG	R/W	Data Alignment Configure 0: Right alignment 1: Left alignment
8:6	EXTTRGSEL	R/W	External Trigger Event Select These bits are used to select the external event for triggering ADC conversion. 000: Event 0 001: Event 1 010: Event 2 011: Event 3 100: Event 4 101: Event 5 110: Event 6 111: Event 7
9	Reserved		
11:10	EXTPOLSEL	R/W	External Trigger Enable and Polarity Select 00: Hardware trigger detection is closed (conversion can be started by software) 01: Hardware trigger detected on rising edge 10: Hardware trigger detected on falling edge 11: Hardware trigger detected on both rising and falling edges
12	OVRMAG	R/W	Overrun Management Mode 0: When an overrun event is detected, ADC_DATA register saves previous data 1: When an overrun event is detected, ADC_DATA register saves the last converted data
13	CMODESEL	R/W	Select Single/Continuous Conversion Mode 0: Single conversion mode 1: Continuous conversion mode
14	WAITCEN	R/W	Wait Conversion Mode Enable 0: Disable 1: Enable
15	AOEN	R/W	Auto-Off Mode Enable 0: Disable 1: Enable

Field	Name	R/W	Description
16	DISCEN	R/W	Discontinuous Mode Enable 0: Disable 1: Enable
21:17	Reserved		
22	AWDCHEN	R/W	Enable The Watchdog On A Single Channel or on All Channels 0: Enable analog watchdog on all channels 1: Enable analog watchdog on a single channel
23	AWDEN	R/W	Analog Watchdog Enable 0: Disable 1: Enable
25:24	Reserved		
30:26	AWDCHSEL	R/W	Analog Watchdog Channel Select These bits are used to configure the input channel for the analog watchdog to monitor ADC 00000: Channel 0 00001: Channel 1 10010: Channel 18 Other values: Reserved, not used Note: The channel selected by AWDCHSEL bit must be written in CHSELR register
31	Reserved		

Note: These bits can be rewritten only when STARTCEN=0 (confirming no ongoing conversion).

28.5.5 ADC configuration register 2 (ADC_CFG2)

Offset address: 0x10

Reset value: 0x0000 0000

Field	Name	R/W	Description
29:0	Reserved		
31:30	CLKCFG	R/W	ADC Clock Mode Configure 00: ADCCLK (asynchronous clock mode) 01: PCLK/2 (synchronous clock mode) 10: PCLK/4 (synchronous clock mode) 11: Reserved Note: The software allows writing these bits only when ADC is disabled.

28.5.6 ADC sampling time register (ADC_SMPTIM)

Offset address: 0x14

Reset value: 0x0000 0000

Field	Name	R/W	Description
-------	------	-----	-------------

Field	Name	R/W	Description
2:0	SMPCYCSEL	R/W	Sampling Cycles Selecte 000: 1.5ADC clock cycles 001: 7.5ADC clock cycles 010: 13.5ADC clock cycles 011: 28.5ADC clock cycles 100: 41.5ADC clock cycles 101: 55.5ADC clock cycles 110: 71.5ADC clock cycles 111: 239.5ADC clock cycles Note: These bits can be rewritten only when STARTCEN=0.
31:3	Reserved		

28.5.7 ADC watchdog threshold register (ADC_AWDT)

Offset address: 0x20

Reset value: 0x0FFF 0000

Field	Name	R/W	Description
11:0	AWDLT[11:0]	R/W	Analog Watchdog Low Threshold
15:12	Reserved		
27:16	AWDHT[11:0]	R/W	Analog Watchdog High Threshold
31:28	Reserved		

Note: These bits can be rewritten only when STARTCEN=0.

28.5.8 ADC channel selection register (ADC_CHSEL)

Offset address: 0x28

Reset value: 0x0000 0000

Field	Name	R/W	Description
17:0	CHxSEL	R/W	Channel-x Select 0: Input channel x is not selected as conversion channel 1: Input channel x is selected as conversion channel
31:18	Reserved		

Note: These bits can be rewritten only when STARTCEN=0.

28.5.9 ADC data register (ADC_DATA)

Offset address: 0x40

Reset value: 0x0000 0000

Field	Name	R/W	Description
15:0	CDATA[15:0]	R	Converted Data These bits are read-only. Include the conversion result values of last conversion channel. CDATA[6:0] value is calibration factor only when calibration is completed.
31:16	Reserved		

28.5.10 ADC common configuration register (ADC_CCFG)

Offset address: 0x308

Reset value: 0x0000 0000

Field	Name	R/W	Description
21:0			Reserved
22	VREFEN	R/W	V _{REFINT} Enable 0: Disable 1: Enable
23			Reserved
24	VBATEN	R/W	V _{BAT} Enable 0: Disable 1: Enable
31:25			Reserved

Note: This bit can be rewritten only when STARTCEN=0.

29 Digital-to-analog Converter (DAC)

29.1 Introduction

DAC is a digital/analog converter which can be configured to input 8-bit or 12-bit data and output voltage. In input 12-bit data mode, the data can be set to be left or right aligned. It has two-way DAC output channels, which do not affect each other; each channel has multiple trigger sources to trigger conversion; a single channel can trigger conversion output, or both channels can trigger conversion output at the same time. Both channels can generate noise waveform and triangle waveform independently.

29.2 Main Characteristics

- (1) Left alignment/Right alignment of data in 12-bit mode
- (2) Synchronous update function
- (3) Noise generation
- (4) Triangle waveform generation
- (5) Independent or synchronous conversion
- (6) Support DMA function
- (7) Detection DMA underrun error
- (8) External trigger conversion
- (9) Programmable internal buffer
- (10) Input voltage reference V_{DDA}

29.3 Structure Block Diagram

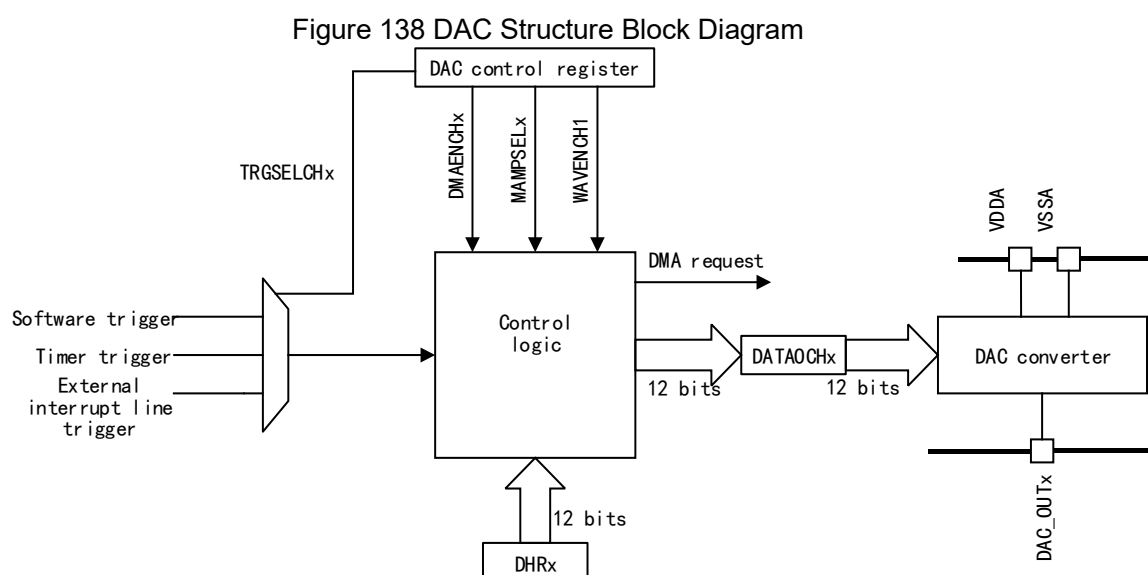

29.4 Functional Description

29.4.1 DAC Pin

Table 104 DAC Pins

Name	Instruction	Signal type
V _{DDA}	Analog power supply	Input, analog power supply
V _{SSA}	Analog power ground	Input, analog power ground
DAC_OUTx	Analog output of DAC Channel x	Analog output signal

29.4.2 DAC Data Format

Single-channel DAC

The registers that are written in three modes are as follows

- 8-bit data right aligned: DAC_DH8Rx[7:0]
- 12-bit data left aligned: DAC_DH12Lx[15:4]
- 12-bit data right aligned: DAC_DH12Rx[11:0]

Double-channel DAC

The registers that are written in three modes are as follows

- 8-bit data right aligned: DAC_DH8RDUAL[15:0]
- 12-bit data left aligned: DAC_DH12LDUAL[15:4],
DAC_DH12LDUAL[31:20]
- 12-bit data right aligned: DAC_DH12RDUAL[11:0],
DAC_DH12RDUAL[27:16]

29.4.3 DAC Channel Enable

Each DAC channel can be powered on by setting the corresponding ENCHx bit in DAC_CTRL register. Then after the start time is woken up, enable each DAC channel.

Note: ENCHx bit can only enable the analog part of DAC Channel x. Even if ENCHx bit is cleared, the digital interface of DAC channel will also be enabled.

29.4.4 DAC Output Buffer Enable

DAC integrates an output buffer, and it can be used to reduce the output impedance and drive the external load directly, not needing adding an external operational amplifier.

DAC channel output buffer can be enabled and disabled through the corresponding BUFFDCHx bit in DAC_CTRL register.

29.4.5 DAC Reference Voltage and Output

DAC uses V_{DDA} as reference voltage and by grounding the V_{SSA}, the output voltage range of DAC can be obtained, namely: V_{DDA}.

DAC output calculation formula is: $\text{DAC output} = V_{\text{DDA}} * (\text{DATAOCH}/4095)$

29.4.6 DAC Conversion

DAC output can obtain corresponding voltage value by calculating the data in DAC_DATAOCHx register. However, it is impossible to write data directly to DAC_DATAOCHx register, and it is required to write to DAC_DHx register and then through corresponding trigger, load the data in DAC_DHx to DAC_DATAOCHx.

29.4.7 DAC Double-channel Conversion

When two channels work at the same time, the written data can be written to the common registers: DH8RDUAL, DH12RDUAL and DH12LDUAL, so as to effectively use the bus bandwidth.

Dual-channel conversion can be divided into independent conversion and synchronous conversion. The specific configuration and description are as follows.

29.4.7.1 Independent trigger

Waveform generator disabled

- (1) Enable two-channel trigger mode;
- (2) Configure two channels and use different trigger sources.

Use the same LFSR

- (1) Enable two-channel trigger mode;
- (2) Configure two channels and use different trigger sources;
- (3) Enable the noise generation function of two channels, and set the same LFSR mask value.

Use different LFSR

- (1) Enable two-channel trigger mode;
- (2) Configure two channels and use different trigger sources;
- (3) Enable the noise generation function of two channels, and set different LFSR mask values.

Generate the same triangle wave

- (1) Enable two-channel trigger mode;
- (2) Configure two channels and use different trigger sources;
- (3) Enable the triangle wave generation function of two channels, and set the same triangular amplitude.

Generate different triangle waves

- (1) Enable two-channel trigger mode;
- (2) Configure two channels and use different trigger sources;
- (3) Enable the triangle wave generation function of two channels, and set different triangular amplitudes.

29.4.7.2 Synchronous trigger

Synchronous software startup

Disable the trigger mode of two channels; after writing data, wait for one APB1 clock cycle and then transfer to DAC_DATAOCH1 and DAC_DATAOCH2 registers at the same time.

Waveform generator disabled

- (1) Enable two-channel trigger mode;
- (2) Configure two channels and use the same trigger source.

Use the same LFSR

- (1) Enable two-channel trigger mode;
- (2) Configure two channels and use the same trigger source;
- (3) Enable the noise generation function of two channels, and set the same LFSR mask value.

Use different LFSR

- (1) Enable two-channel trigger mode;
- (2) Configure two channels and use the same trigger source;
- (3) Enable the noise generation function of two channels, and set different LFSR mask values.

Generate the same triangle wave

- (1) Enable two-channel trigger mode;
- (2) Configure two channels and use the same trigger source;
- (3) Enable the triangle wave generation function of two channels, and set the same triangular amplitude.

Use different triangle waves

- (1) Enable two-channel trigger mode;
- (2) Configure two channels and use the same trigger source;
- (3) Enable the triangle wave generation function of two channels, and set different triangular amplitudes.

29.4.8 DAC Trigger Source

When the channel trigger is disabled (TRGENCHx bit in the register DAC_CTRL is set to 0), write the value in DAC_DHx register and it will be automatically transferred to DAC_DATAOCHx after one APB1 clock cycle.

When the channel trigger is enabled (TRGENCHx bit in the register DAC_CTRL is set to 1), write the value in DAC_DHx register and it will be transferred to DAC_DATAOCHx after different clock cycles according to the selected trigger source. Three types of trigger sources can be selected:

- Timer update event
- External interrupt trigger
- Software trigger

Table 105 External Trigger

Trigger source	Type	TSELCH1
TMR6_TRGO event	Internal signal from on-chip timer	000
TMR3_TRGO event		001
TMR7_TRGO event		010
TMR15_TRGO event		011
TMR2_TRGO event		100
Reserved		101
EINT Line 9	External pin	110
SWTRG	Software control bit	111

When the update event and external interrupt of the timer are selected as the trigger source, the transmission will be completed after three APB clock cycles; when software trigger is selected, the transmission will be completed after one APB1 clock cycle.

When transmitting the data to DAC_DATAOCHx register, after a period of time, the digital quantity will be outputted after it is converted linearly into analog voltage. The intermediate conversion time will vary according to the power supply voltage and the analog output load.

29.4.9 DAC Waveform Generation

Each channel of DAC can independently generate noise and triangle wave.

29.5 Register Address Mapping

Table 106 DAC Register Address Mapping

Register name	Description	Offset address
DAC_CTRL	DAC control register	0x00
DAC_SWTRG	DAC software Trigger Register	0x04
DAC_DH12R1	DAC Channel 1 12-bit right-aligned data holding register	0x08
DAC_DH12L1	DAC Channel 1 12-bit left-aligned data holding register	0x0C
DAC_DH8R1	DAC Channel 1 8-bit right-aligned data holding register	0x10
DAC_DH12R2	DAC Channel 2 12-bit right-aligned data holding register	0x14
DAC_DH12L2	DAC Channel 2 12-bit left-aligned data holding register	0x18
DAC_DH8R2	DAC Channel 2 8-bit right-aligned data holding register	0x1C
DAC_DH12RDUAL	Dual-DAC 12-bit right-aligned data holding register	0x20
DAC_DH12LDUAL	Dual-DAC 12-bit left-aligned data holding register	0x24
DAC_DH8RDUAL	Dual-DAC 8-bit right-aligned data holding register	0x28
DAC_DATAOCH1	DAC Channel 1 data output register	0x2C
DAC_DATAOCH2	DAC Channel 2 data output register	0x30
DAC_STS	DAC state register	0x34

29.6 Register Functional Description

29.6.1 DAC control register (DAC_CTRL)

Offset address: 0x00

Reset value: 0x0000 0000

Field	Name	R/W	Description
0	ENCH1	R/W	DAC Channel1 Enable 0: Disable 1: Enable
1	BUFFDCH1	R/W	DAC Channel1 Output Buffer Disable 0: Enable 1: Disable
2	TRGENCH1	R/W	DAC Channel1 Trigger Enable 0: Disable 1: Enable
5:3	TRGSELCH1	R/W	DAC Channel1 Trigger Source Select The trigger source can be selected through this register when Channel 1 trigger is enabled (TRGENCH1=1). 000: TMR6 TRGO event 001: TMR3 TRGO event 010: TMR7 TRGO event 011: TMR15 TRGO event 100: TMR2 TRGO event 101: Reserved 110: External interrupt line 9 111: Software trigger
7:6	WAVENCH1	R/W	DAC Channel1 Noise/Triangle Wave Generation Enable 00: Waveform is not generated 10: Noise waveform is generated 1x: Triangle waveform is generated
11:8	MAMPSELCH1	R/W	Select DAC Channel1 LFSR Bit Mask/Triangle Wave Amplitude Selector In the mode of “generating LFSR noise”, select the bit to mask LFSR through this bit; In the mode of “generating triangle wave”, select the amplitude of triangle wave through this bit. 0000: Unmask LFSR bit 0/triangle wave amplitude is 1 0001: Unmask LFSR bit [1:0]/triangle wave amplitude is 3 0010: Unmask LFSR bit [2:0]/triangle wave amplitude is 7 0011: Unmask LFSR bit [3:0]/triangle wave amplitude is 15 0100: Unmask LFSR bit [4:0]/triangle wave amplitude is 31 0101: Unmask LFSR bit [5:0]/triangle wave amplitude is 63 0110: Unmask LFSR bit [6:0]/triangle wave amplitude is 127 0111: Unmask LFSR bit [7:0]/triangle wave amplitude is 255 1000: Unmask LFSR bit [8:0]/triangle wave amplitude is 511 1001: Unmask LFSR bit [9:0]/triangle wave amplitude is 1023 1010: Unmask LFSR bit [10:0]/triangle wave amplitude is 2047 ≥1011: Unmask LFSR bit [11:0] / triangle wave amplitude is 4095
12	DMAENCH1	R/W	DAC Channel1 DMA Enable

Field	Name	R/W	Description
			0: Disable 1: Enable
13	DMAUDRIEN1	R/W	DAC Channel1 DMA Underrun Interrupt Enable 0: Disable 1: Enable
15:14	Reserved		
16	ENCH2	R/W	DAC Channel2 Enable 0: Disable 1: Enable
17	BUFFDCH2	R/W	DAC Channel2 Output Buffer Disable 0: Enable 1: Disable
18	TRGENCH2	R/W	DAC Channel2 Trigger Enable 0: Disable 1: Enable
21:19	TRGSELCH2	R/W	DAC Channel2 Trigger Source Select The trigger source can be selected through this register when Channel 2 trigger is enabled (TRGENCH2=1) 000: TMR6 TRGO event 001: TMR3 TRGO event 010: TMR7 TRGO event 011: TMR15 TRGO event 100: TMR2 TRGO event 101: Reserved 110: External interrupt line 9 111: Software trigger
23:22	WAVENCH2	R/W	DAC Channel2 Noise/Triangle Wave Generation Enable 00: Waveform is not generated 01: Noise waveform is generated 1x: Triangle waveform is generated
27:24	MAMPSELCH2	R/W	Select DAC Channel2 LFSR Bit Mask/Triangle Wave Amplitude Selector In the mode of “generating LFSR noise”, select the bit to mask LFSR through this bit; In the mode of “generating triangle wave”, select the amplitude of triangle wave through this bit. 0000: Unmask LFSR bit 0/triangle wave amplitude is 1 0001: Unmask LFSR bit [1:0]/triangle wave amplitude is 3 0010: Unmask LFSR bit [2:0]/triangle wave amplitude is 7 0011: Unmask LFSR bit [3:0]/triangle wave amplitude is 15 0100: Unmask LFSR bit [4:0]/triangle wave amplitude is 31 0101: Unmask LFSR bit [5:0]/triangle wave amplitude is 63 0110: Unmask LFSR bit [6:0]/triangle wave amplitude is 127 0111: Unmask LFSR bit [7:0]/triangle wave amplitude is 255 1000: Unmask LFSR bit [8:0]/triangle wave amplitude is 511 1001: Unmask LFSR bit [9:0]/triangle wave amplitude is 1023 1010: Unmask LFSR bit [10:0]/triangle wave amplitude is 2047 ≥1011: Unmask LFSR bit [11:0] / triangle wave amplitude is 4095

Field	Name	R/W	Description
28	DMAENCH2	R/W	DAC Channel2 DMA Enable 0: Disable 1: Enable
29	DMAUDRIEN2	R/W	DAC Channel2 DMA Underrun Interrupt Enable 0: Disable 1: Enable
31:30	Reserved		

29.6.2 DAC software trigger register (DAC_SWTRG)

Offset address: 0x04

Reset value: 0x0000 0000

Field	Name	R/W	Description
0	SWTRG1	W	DAC Channel1 Software Trigger Enable This bit can be set to 1 and cleared by software; once the data in the register DAC_DH1 is transferred to the register DAC_DATAOCH1, this bit will be cleared by hardware. 0: Disable 1: Enable
1	SWTRG2	W	DAC Channel2 Software Trigger Enable This bit can be set to 1 and cleared by software; once the data in the register DAC_DH2 is transferred to the register DAC_DATAOCH2, this bit will be cleared by hardware. 0: Disable 1: Enable
31:2	Reserved		

29.6.3 DAC Channel 1 12-bit right-aligned data holding register (DAC_DH12R1)

Offset address: 0x08

Reset value: 0x0000 0000

Field	Name	R/W	Description
11:0	DATA	R/W	DAC Channel1 12-bit Right-Aligned Data This bit is written by the software, representing the data of 12-bit DAC channel 1
31:12	Reserved		

29.6.4 DAC Channel 1 12-bit left-aligned data holding register (DAC_DH12L1)

Offset address: 0x0C

Reset value: 0x0000 0000

Field	Name	R/W	Description
3:0	Reserved		
15:4	DATA	R/W	DAC Channel1 12-Bit Left-Aligned Data
31:16	Reserved		

29.6.5 DAC Channel 1 8-bit right-aligned data holding register (DAC_DH8R1)

Offset address: 0x10
Reset value: 0x0000 0000

Field	Name	R/W	Description
7:0	DATA	R/W	DAC Channel1 8-bit Right-Aligned Data
31:8	Reserved		

29.6.6 DAC Channel 2 12-bit right-aligned data holding register (DAC_DH12R2)

Offset address: 0x14
Reset value: 0x0000 0000

Field	Name	R/W	Description
11:0	DATA	R/W	DAC Channel2 12-bit Right-Aligned Data
31:12	Reserved		

29.6.7 DAC Channel 2 12-bit left-aligned data holding register (DAC_DH12L2)

Offset address: 0x18
Reset value: 0x0000 0000

Field	Name	R/W	Description
3:0	Reserved		
15:4	DATA	R/W	DAC Channel2 12-Bit Left-Aligned Data
31:16	Reserved		

29.6.8 DAC Channel 2 8-bit right-aligned data holding register (DAC_DH8R2)

Offset address: 0x1C
Reset value: 0x0000 0000

Field	Name	R/W	Description
7:0	DATA	R/W	DAC Channel2 8-bit Right-Aligned Data
31:8	Reserved		

29.6.9 Dual-DAC 12-bit right-aligned data holding register (DAC_DH12RDUAL)

Offset address: 0x20
Reset value: 0x0000 0000

Field	Name	R/W	Description
11:0	DATA1	R/W	DAC Channel1 12-bit Right-Aligned Data
15:12	Reserved		
27:16	DATA2	R/W	DAC Channel2 12-bit Right-Aligned Data
31:28	Reserved		

29.6.10 Dual-DAC 12-bit left-aligned data holding register (DAC_DH12LDUAL)

Offset address: 0x24

Reset value: 0x0000 0000

Field	Name	R/W	Description
3:0			Reserved
15:4	DATACH1	R/W	DAC Channel1 12-Bit Left-Aligned Data
19:16			Reserved
31:20	DATACH2	R/W	DAC Channel2 12-Bit Left-Aligned Data

29.6.11 Dual-DAC 8-bit right-aligned data holding register (DAC_DH8RDUAL)

Offset address: 0x28

Reset value: 0x0000 0000

Field	Name	R/W	Description
7:0	DATACH1	R/W	DAC Channel1 8-bit Right-Aligned Data
15:8	DATACH2	R/W	DAC Channel2 8-bit Right-Aligned Data
31:16			Reserved

29.6.12 DAC Channel 1 data output register (DAC_DATAOCH1)

Offset address: 0x2C

Reset value: 0x0000 0000

Field	Name	R/W	Description
11:0	DATA	R	DAC Channel1 Data Output
31:12			Reserved

29.6.13 DAC Channel 2 data output register (DAC_DATAOCH2)

Offset address: 0x30

Reset value: 0x0000 0000

Field	Name	R/W	Description
11:0	DATA	R	DAC Channel2 Data Output
31:12			Reserved

29.6.14 DAC state register (DAC_STS)

Offset address: 0x34

Reset value: 0x0000 0000

Field	Name	R/W	Description
12:0			Reserved
13	DMAUDRFLG1	RC_W1	DAC Channel1 DMA Underrun Flag This bit is cleared by software and set to 1 by hardware. 0: No error

Field	Name	R/W	Description
			1: Error
28:14	Reserved		
29	DMAUDRFLG2	RC_W1	DAC Channel1 DMA Underrun Flag This bit is cleared by software and set to 1 by hardware. 0: No error 1: Error
31:30	Reserved		

30 Touch Sensing Controller (TSC)

30.1 Introduction

The touch sensing controller (TSC) provides a capacitive touch solution, which adopts the charge transfer and acquisition principle. If the finger or other charged body approaches the charging electrode, the capacitance may be changed, thus affecting the number of charging times of the sampling capacitor. According to the change of the number of charging times, the touch operation can be captured.

30.2 Main Characteristics

- (1) Charge transfer and acquisition principle
- (2) Up to eight analog I/O groups
 - Up to 24 channels supported
 - Sampling I/O and charging I/O can be set
- (3) Configurable charge transmit frequency and duty cycle
- (4) Have the spread spectrum function, improving the robustness
- (5) The hardware manages charging and discharging sequence
- (6) Maximum count value that can be set
- (7) I/O 410chmitt hysteresis control
- (8) Normal acquisition and synchronous acquisition modes
- (9) Compatible with point contact, linear and rotary touch recognition
- (10) Interrupt of two charge transfer states

30.3 Structure Block Diagram

Figure 139 Structure Block Diagram

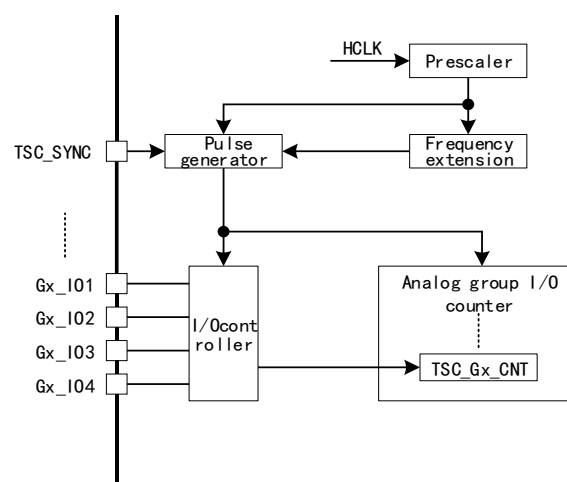

30.4 Functional Description

30.4.1 Analog I/O Group

TSC has up to 8 analog I/O groups, and each analog I/O group has 4 I/O ports, and an analog I/O group counter.

Four I/O ports in analog I/O group can assign sampling I/O and charging I/O at will and be configured through the registers TSC_IOSMPCTRL and TSC_IOCHCTRL.

In the process of charge transfer and acquisition, a pair of I/O is needed to operate together. The charging I/O charges the external electrode first, and the electrode transfers the charge to the sampling capacitor connected to the sampling I/O within the set time; repeat the process. When the sampling I/O reaches the threshold V_{IH} , the counter will latch the number of charging times of the current analog I/O group.

Charge transfer is a periodic action. If multiple analog I/O groups work, only when the last sampling I/O detects the threshold value V_{IH} , will all analog I/O groups stop charging and discharging the external electrode.

Sampling I/O

Sampling I/O is used to detect the voltage on the external sampling capacitor. When the voltage is the threshold value of V_{IH} , it indicates that the acquisition cycle is completed. At any time, each analog I/O group has only one sampling I/O, so it supports up to 24 charging electrode channels.

Sampling I/O should be configured as open-drain multiplexing.

Charging I/O

The charging I/O charges the external electrode periodically, meanwhile, the internal switch acts periodically, to transfer the charge from the electrode to the external sampling capacitor. The charge transfer process for the electrode is the discharging process.

In some scenes that it is required to increase the area of charging electrode to detect touch action, the effective area of electrode can be increased through one sampling I/O together with three charging I/Os.

Charging I/O should be configured as push-pull multiplexing.

30.4.2 Charge Transfer Clock

The clock source of TSC is high-speed HCLK, and one charging and discharging process of charging I/O is one charge transfer cycle.

There is a prescaler PGPSC inside, which can be used to divide the HCLK frequency to obtain the clock of the pulse generator. Through CTPHSEL and CTPLSEL bits of the register TSC_CTRL, the number of clocks of pulse generator used in charging and discharging processes can be configured, and the charge transfer frequency is:

$$f_Q = \frac{f_{HCLK}}{PGPSC + ((CTPHSEL + 1) + (CTPLSEL + 1))}$$

The duty cycle of charge transfer frequency is:

$$Duty_Q = \frac{CTPHSEL + 1}{(CTPHSEL + 1) + (CTPLSEL + 1)}$$

As for the charge transfer cycle, during the high-level period, the charging I/O

charges the external electrode to ensure that the electrode is fully charged; during the low-level period, the external electrode is in the discharge state to ensure the completion of charge transfer.

30.4.3 Frequency Spreading

The frequency spreading function can generate variable charge transfer cycle and improve the robustness of charge transfer in some harsh environments.

The spread spectrum function is 412chmitt by SSEN bit of the register TSC_CTRL, the spread spectrum clock is obtained through frequency division of HCLK, and the frequency division factor is set by SSCDFSEL bit of the register TSC_CTRL.

Table 107 Extended Frequency Deviation and AHB Clock Frequency

HCLK	Step size of spread spectrum	Maximum spread spectrum error
48MHz	0.0208us	5.3333us

30.4.4 Charge Transfer Mechanism

In general, charge transfer is a periodic process.

High-level moment of pulse

The internal connection between the charging I/O and the sampling I/O is disconnected, and the charging I/O charges the external electrode. If CTPHSEL is set too small, the electrode will not be fully charged, which will affect the subsequent discharge process.

Low-level moment of pulse

The internal connection between the charging I/O and the sampling I/O is closed, and the charge on the electrode is transferred to the external sampling capacitor. If CTPLSEL is too small, the electrode discharge will be affected, and the charging time will be reduced for the sampling capacitor.

Touch moment

After periodic charge transfer, when the sampling I/O level reaches the threshold value, the counter of the current analog I/O group will latch the count value of the number of charge and discharge times.

The touch action causes change in the capacitance on the electrode, which will make the sampling I/O reach the threshold ahead of time, and the count value of the counter latch will become smaller. According to the change of the count value, the user can obtain the state of the touch.

30.4.5 Maximum Error Count

The maximum error count limit is a timeout processing mechanism. When an analog I/O group is abnormal, namely, the sampling I/O level cannot recognize the threshold within the set charge and discharge times, the count timeout error will be triggered, and the hardware will immediately stop the current charge transfer operation. The corresponding error flag bit MCEFLG is set. If the maximum error count interrupt is turned on, the interrupt will be generated.

Since the current charge transfer is stopped, the relevant flag bit EOAFGL will

also be set, and if the EOAIEN interrupt is turned on, the interrupt will be triggered.

Note: When the maximum error count occurs, the GxCFLG flag bit of the current analog I/O group will not be set.

30.4.6 Schmitt Hysteresis Control

TSC can control the 413chmitt hysteresis of each analog I/O group. In most of the time, in order to improve the anti-interference characteristics of the touch sensing circuit, it is required to turn off the 413chmitt hysteresis of the corresponding I/O and realize it through the register TSC_IOHCR.

At the same time, in order to further improve the anti-interference capability, it is suggested that the I/O port should be configured with low rate and medium rate.

30.4.7 Acquisition Mode

TSC has normal acquisition mode and synchronous acquisition mode, which are selected by AMCFG bit of the register TSC_CTRL. In normal mode, when STARTAFLG is set to start acquisition, the analog I/O group will immediately turn on the charge transfer. In synchronous acquisition mode, set the STARTAFLG bit, and the synchronization pin will not trigger charge transfer until the external synchronization signal arrives.

The synchronous acquisition mode plays an important role when synchronous TSC acquisition touch operation of the external signal is needed.

When the sampling I/O of the analog I/O group detects the threshold level, the corresponding GxCFLG flag bit will be set; when the threshold level is detected by all opened analog I/O groups, the EOAFGL flag bit will be set.

30.4.8 Multiple Touch Recognition

Using multiple analog I/O groups, through reasonable design of charging electrode, combined with the count value of each analog I/O group, linear, rotary and other touch recognition can be realized.

30.4.9 Low-power Mode

Table 108 Interrupt Control Bit

Interrupt type	Flag bit	Exit the sleep mode	Exit the stop mode	Exit the standby mode
Acquisition completion interrupt	EOAFGL	Yes	No	No
Maximum error count interrupt	MCEFLG	Yes	No	No

30.5 Register Address Mapping

Table 109 TSC Register Address Mapping Table

Register name	Description	Offset address
TSC_CTRL	TSC control register	0x00
TSC_INTEN	TSC interrupt enable register	0x04
TSC_INTFCLR	TSC interrupt flag clear register	0x08
TSC_INTSTS	TSC interrupt state register	0x0C
TSC_IOHCTRL	TSC I/O hysteresis control register	0x10

Register name	Description	Offset address
TSC_IOASWCTRL	TSC I/O analog switch control register	0x18
TSC_IOSMPCTRL	TSC I/O sampling controller	0x20
TSC_IOCHCTRL	TSC I/O channel control register	0x28
TSC_IOGCSTS	TSC I/O group control state register	0x30
TSC_IOGxCNT	TSC I/O group x count register	0x30+0x04× analog I/O group number

30.6 Register Functional Description

30.6.1 TSC control register (TSC_CTRL)

Offset address: 0x00

Reset value: 0x0000 0000

Field	Name	R/W	Description
0	TSCEN	R/W	Touch Sensing Controller Enable 0: Disable 1: Enable Note: If TSCEN is 0, other settings of TSC register will not work. Note: When the touch sensing controller is disabled, the setting of TSC register will not work.
1	STARTAFLG	R/W	Start Acquisition Flag Acquisition starts when this bit is set to 1 by software, and it is cleared by hardware when the acquisition is completed. 0: Acquisition does not start 1: Start new acquisition
2	AMCFG	R/W	Acquisition Mode Configure 0: Normal acquisition mode 1: Synchronous acquisition mode Note: These values cannot be changed in acquisition process.
3	SYNCPOL	R/W	Synchronization Pin Polarity Configure This bit is used to select the signal polarity of synchronization input pin. 0: Only falling edge 1: Rising edge and high level
4	IODEF CFG	R/W	I/O Default Mode Configure This bit is used to define all I/O configurations not in the acquisition state and unused I/O configurations in the acquisition state. 0: Push-pull output low-level mode 1: Floating input mode Note: These values cannot be changed in acquisition process.
7:5	MCNTVSEL	R/W	Max Count Value Select These bits are used to define the maximum number of charge transfer pulses before the maximum count error is generated. 000: 255 001: 511 010: 1023 011: 2047 100: 4095 101: 8191 110: 16383 111: Reserved Note: These values cannot be changed in acquisition process.
11:8	Reserved		

Field	Name	R/W	Description
14:12	PGCDFSEL	R/W	<p>Pulse Generator Clock Divide Factor Select</p> <p>These bits are used to select the frequency division factor of AHB clock to generate pulse generator clock (f_{PGCLK}).</p> <p>000: f_{HCLK} 001: f_{HCLK}/2 010: f_{HCLK}/4 011: f_{HCLK}/8 100: f_{HCLK}/16 101: f_{HCLK}/32 110: f_{HCLK}/64 111: f_{HCLK}/128</p> <p>Note: These values cannot be changed in acquisition process.</p>
15	SSCDFSEL	R/W	<p>Spread Spectrum Clock Divide Factor Select</p> <p>This bit is used to select the division factor of AHB clock to generate the spread spectrum clock (f_{SSCLK}).</p> <p>0: f_{HCLK} 1: f_{HCLK}/2</p> <p>Note: These values cannot be changed in acquisition process.</p>
16	SSEN	R/W	<p>Spread Spectrum Enable</p> <p>0: Disable 1: Enable</p> <p>Note: These values cannot be changed in acquisition process.</p>
23:17	SSERRVSEL	R/W	<p>Spread Spectrum Error Value Select</p> <p>These bits define the spread spectrum error value, and the variable f_{SSCLK} cycle will be inserted into the high-level cycle of the charge pulse.</p> <p>0000000: 1x t_{SSCLK} 0000001: 2x t_{SSCLK} ... 1111111: 128x t_{SSCLK}</p> <p>Note: These values cannot be changed in acquisition process.</p>
27:24	CTPLSEL	R/W	<p>Charge Transfer Pulse Low Level Duration Select</p> <p>0000: 1x t_{PGCLK} 0001: 2x t_{PGCLK} ... 1111: 16x t_{PGCLK}</p> <p>Note: These values cannot be changed in acquisition process.</p>
31:28	CTPHSEL	R/W	<p>Charge Transfer Pulse High Level Duration Select</p> <p>0000: 1x t_{PGCLK} 0001: 2x t_{PGCLK} ... 1111: 16x t_{PGCLK}</p> <p>Note: These values cannot be changed in acquisition process.</p>

30.6.2 TSC interrupt enable register (TSC_INTEN)

Offset address: 0x04

Power-on reset value: 0x0000 0000

Field	Name	R/W	Description
0	EOAIEN	R/W	<p>End of Acquisition Interrupt Enable</p> <p>0: Disable 1: Enable</p>
1	MCEIEN	R/W	<p>Max Count Error Interrupt Enable</p> <p>0: Disable 1: Enable</p>
31:2	Reserved		

30.6.3 TSC interrupt flag clear register (TSC_INTFCLR)

Offset address: 0x08

Reset value: 0x0000 0000

Field	Name	R/W	Description
0	EOAICLR	R/W	End of Acquisition Interrupt Flag Clear This bit is used to clear the corresponding EOAFLG flag in TSC_INTSTS register. 0: Invalid 1: Clear
1	MCEICLR	R/W	Max Count Error Interrupt Flag Clear This bit is used to clear the corresponding MCEFLG flag in TSC_INTSTS register. 0: Invalid 1: Clear
31:2	Reserved		

30.6.4 TSC interrupt state register (TSC_INTSTS)

Offset address: 0x0C

Reset value: 0x0000 0000

Field	Name	R/W	Description
0	EOAFLG	R	End of Acquisition Flag This bit will be set to 1 by hardware after all valid analog I/O port groups have completed acquisition or the maximum count error is generated. When EOAICLR bit of TSC_INTFCLR is set to 1, this bit will be cleared by software. 0: Acquisition is not completed 1: Acquisition has been completed
1	MCEFLG	R	Max Count Error Flag This bit will be set to 1 by hardware when the counter of the analog I/O port group reaches the maximum value. When MCEICLR bit of TSC_INTFCLR is set to 1, this bit will be cleared by software. 0: No maximum count error is generated 1: Maximum count error is generated
31:2	Reserved		

30.6.5 TSC I/O hysteresis control register (TSC_IOHCTRL)

Offset address: 0x10

Reset value: 0xFFFF FFFF

Field	Name	R/W	Description
23:0	Gx_IOy	R/W	Gx_IOy Schmitt Trigger Hysteresis Mode Enable 0: Disable 1: Enable
31:24	Reserved		

30.6.6 TSC I/O analog switch control register (TSC_IOASWCTRL)

Offset address: 0x18

Reset value: 0x0000 0000

Field	Name	R/W	Description
-------	------	-----	-------------

Field	Name	R/W	Description
23:0	Gx_IOy	R/W	Gx_IOy Analog Switch Enable 0: Disable 1: Enable
31:24	Reserved		

30.6.7 TSC I/O sampling control register (SC_IOSMPCTRL)

Offset address: 0x20

Reset value: 0x0000 0000

Field	Name	R/W	Description
23:0	Gx_IOy	R/W	Gx_IOy Sampling Mode Configure These bits are used to configure GX_ Gx_IOy as a sampling capacitor interface, and an analog I/O port group can only define one sampling capacitor. 0: Gx_IOy is not configured as sampling capacitor 1: Gx_IOy is configured as sampling capacitor Note: These values cannot be changed in acquisition process.
31:24	Reserved		

30.6.8 TSC I/O channel control register (TSC_IOCHCTRL)

Offset address: 0x28

Reset value: 0x0000 0000

Field	Name	R/W	Description
23:0	Gx_IOy	R/W	Gx_IOy Channel Mode Configure These bits are used to configure Gx_IOy as channel I/O. 0: Gx_IOy is not configured as channel I/O 1: Gx_IOy is configured as channel I/O Note: These values cannot be changed in acquisition process.
31:24	Reserved		

30.6.9 TSC I/O group control state register (TSC_IOGCSTS)

Offset address: 0x30

Reset value: 0x0000 0000

Field	Name	R/W	Description
7:0	GxEN	R/W	Analog I/O Group x Acquisition Enable 0: Disable 1: Enable
15:8	Reserved		
23:16	GxCFLG	R	Analog I/O Group x Acquisition Completion Flag When the corresponding analog I/O port group is enabled and the acquisition cycle ends, this bit will be set by hardware. This bit will be cleared by hardware when a new acquisition is started. 0: Acquisition action is not started or is in the process 1: Acquisition action has been completed

Field	Name	R/W	Description
			Note: When the maximum count error is detected, the remaining GxCFLG bits will not be set.
31:24	Reserved		

30.6.10 TSC I/O Group x count register (TSC_I0GxCNT) (x=1..8)

Offset address: 0x30+0x04 x analog I/O group number

Reset value: 0x0000 0000

Field	Name	R/W	Description
13:0	CNTVAL	R	Counter Value It indicates the charge migration cycle count of the corresponding analog I/O port group to complete their collection (C _s voltage reaches the set threshold).
31:14	Reserved		

31 Comparator (COMP)

31.1 Full Name and Abbreviation Description of Terms

Table 110 Full Name and Abbreviation Description of Terms

Full name in English	English abbreviation
Comparator	COMP
Invert	INV
Hysteresis	HYS
Input Plus	INP
Input Minus	INM

31.2 Introduction

Two independent general-purpose comparators (COMP1 and COMP2) are embedded in MCU, and they can be used in combination with the timer.

31.3 Main Characteristics

- Rail-to-rail input
- Two comparators can be combined to form a window comparator
- Hysteresis, rate and loss are programmable
- Can generate an interrupt
- Can wake up from the sleep mode and stop mode (through EINT)
- Can work in stop mode

31.4 Structure Block Diagram

Figure 140 COMP Structure Block Diagram

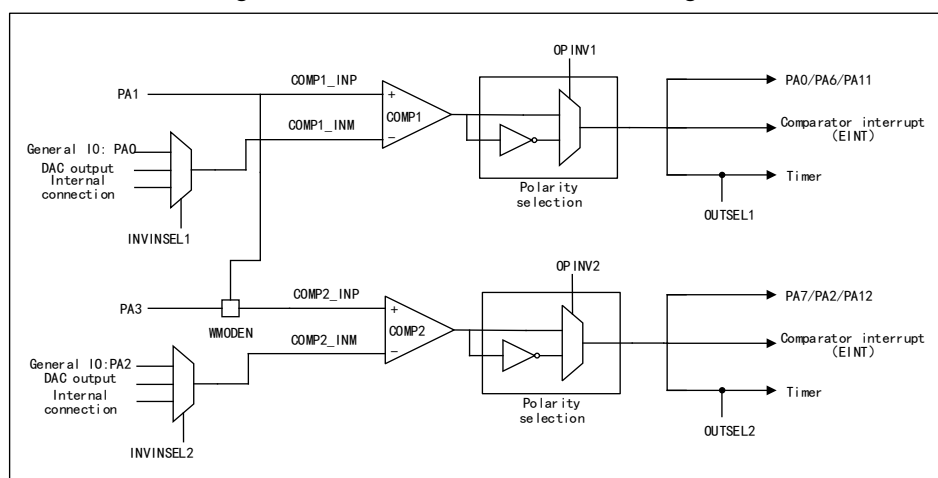

31.5 Functional Description

31.5.1 COMP Clock

COMP has no separate clock enable control bit and works independently of PCLK clock, but its clock is synchronized with PCLK.

COMP can reset the module only through system reset.

31.5.2 COMP Input

It is required to configure the analog mode when GPIO is input as the comparator.

COMP input consists of in-phase input and inverted input. All in-phase inputs are connected to external IO; the inverted input can be programmed and selected, and the external connection has IO pin and DAC output pin; the internal connection has internal reference voltage (V_{REFINT}), and 1/4 or 1/2 or 3/4 of internal reference voltage.

31.5.3 COMP Output

The output of the comparator can be connected to the external IO port;

It can also be connected to the following signals of the internal timer:

- Breaking signal of PWM
- Input signal of OCREF_CLR
- Input capture channel of timer

The output polarity can be modified by programming the OPINVx bit in COMP_CSTS register

31.5.4 COMP Mode

The rate and loss of the comparator are programmable. Considering the practical application, we can program the MODx bit in the register to achieve the most appropriate state.

The comparator has programmable hysteresis function, and choosing the appropriate hysteresis time can avoid the invalid output caused by noise.

Window comparator mode

Connect the in-phase input of COMP1 and COMP2, and disconnect the connection with PA3.

31.5.5 COMP Interrupt

The comparator output is connected to the external interrupt and event controller. If the external interrupt is configured correctly, through DAC output, the interrupt can be generated or MCU entering the sleep and stop mode can be woken up.

31.6 Register Address Mapping

Table 1 COMP Register Address Mapping

Register name	Description	Offset address
COMP_CSTS	COMP control state register	0x1C

31.7 Register Functional Description

31.7.1 COMP control state register (COMP_CSTS)

Offset address: 0x1C

Reset value: 0x0000 0000

The control bit of COMP can have R/W two states, and RW/R means read/write or read-only state.

Field	Name	R/W	Description
0	EN1	RW/R	COMP1 Enable 0: Disable 1: Enable
1	SW1	RW/R	COMP1 Non Inverting Input on PA1 And PA4 Switch When this bit is set, turn off the switch between the in-phase input of the general-purpose comparator COMP1 on PA1 and the I/O of PA4 (DAC). 0: Open 1: Closed
3:2	MOD1	RW/R	COMP1 Mode Control the working mode of the general-purpose comparator COMP1, namely working rate and loss. 00: High rate/Full power 01: Medium rate/Medium power 10: Low rate/Low power 11: Very low rate/Very low power
6:4	INVINSEL1	RW/R	COMP1 Inverting Input Select Select the inverted input signal source connected to the comparator COMP1. 000: 1/4 of V_{REFINT} 001: 1/2 of V_{REFINT} 010: 3/4 of V_{REFINT} 011: V_{REFINT} (internal reference voltage) 100: COMP1_INM4 (PA4, namely DAC_OUT1) 101: COMP1_INM5 (PA5) 110: COMP1_INM6 (PA0) 111 reserved.
7	Reserved		
10:8	OUTSEL1	RW/R	COMP1 Output Select These bits are used to select the output direction of the Comparator COMP1. 000: Not selected 001: TMR1 interrupt input 010: TMR1 input capture 1 011: TMR1 OCrefclear input 100: TMR2 input capture 4 101: TMR2 OCrefclear input 110: TMR3 input capture 1 111: TMR3 OCrefclear input
11	OPINV1	RW/R	COMP1 Output Polarity Invert Output polarity of reverse comparator COMP1 0: In-phase output 1: Inverted output.
13:12	HYSCFG1	RW/R	COMP1 Hysteresis Level Configure Configure the hysteresis level of COMP1 00: No hysteresis

Field	Name	R/W	Description
			01: Low hysteresis 10: Medium hysteresis 11: High hysteresis
14	OUTSTS1	R	COMP1 Output State 0: Low output Under the condition of in-phase output: the in-phase input is lower than the inverted input, and the output is low level Under the condition of inverted output: the in-phase input is higher than the inverted input, and the output is low level 1: High output Under the condition of in-phase output: the in-phase input is higher than the inverted input, and the output is high level Under the condition of inverted output: the in-phase input is lower than the inverted input, and the output is high level
15	LOCK1	R/S	COMP1 Lock This bit can be written once only and is set by software and can only be cleared through system reset. When locked, all control bits of COMP1 will become read-only. 0: COMP1 control bit is readable and writable 1: COMP1 control bit is read-only
16	EN2	RW/R	COMP2 Enable 0: Disable 1: Enable
17	Reserved		
19:18	MOD2	RW/R	COMP2 Mode Control the working mode of the general-purpose comparator COMP2, namely working rate and loss. 00: High rate/Full power 01: Medium rate/Medium power 10: Low rate/Low power 11: Very low rate/Very low power
22:20	INVINSEL2	RW/R	COMP2 Inverting Input Select Select the inverted input signal source connected to the comparator COMP2. 000: 1/4 of V_{REFINT} 001: 1/2 of V_{REFINT} 010: 3/4 of V_{REFINT} 011: V_{REFINT} (internal reference voltage) 100: COMP2_INM4 (PA4, namely DAC_OUT1) 101: COMP2_INM5 (PA5) 110: COMP2_INM6 (PA0) 111: Reserved
23	WMODEN	RW/R	Window Mode Enable Two general-purpose comparators can be connected to become the window comparator mode. 0: Disable 1: Enable
26:24	OUTSEL2	RW/R	COMP2 Output Select Select the output direction of the comparator COMP2. 000: Not selected 001: Timer 1 interrupt input 010: Timer 1 input capture 1 011: Timer 1 OCrefclear input 100: Timer 2 input capture 4

Field	Name	R/W	Description
			101: Timer 2 OCrefclear input 110: Timer 3 input capture 1 111: Timer 3 OCrefclear input
27	OPINV2	RW/R	COMP2 Output Polarity Invert Output polarity of reverse comparator COMP2 0: In-phase output 1: Inverted output
29:28	HYSCFG2	RW/R	COMP2 Hysteresis Level Configure 00: No hysteresis 01: Low hysteresis 10: Medium hysteresis 11: High hysteresis
30	OUTSTS2	R	COMP2 Output State 0: Low output Under the condition of in-phase output: the in-phase input is lower than the inverted input, and the output is low level Under the condition of inverted output: the in-phase input is higher than the inverted input, and the output is low level 1: High output Under the condition of in-phase output: the in-phase input is higher than the inverted input, and the output is high level Under the condition of inverted output: the in-phase input is lower than the inverted input, and the output is high level
31	LOCK2	R/S	COMP2 Lock This bit can be written once only and is set by software and can only be cleared through system reset. When locked, all control bits of COMP2 will become read-only. 0: COMP2 control bit is readable and writable 1: COMP2 control bit is read-only

32 Cyclic Redundancy Check Computing Unit (CRC)

32.1 Introduction

The cyclic redundancy check (CRC) computing unit can get 8/16/32-bit CRC computing result by calculating the input data through a fixed generator polynomial, which is mainly used to detect or verify the correctness and integrity of the data after transmission or saving.

32.2 Functional Description

32.2.1 Calculation Method

Use CRC-32 (Ethernet) polynomial: 0x4C11DB7

$$(X^{32}+X^{26}+X^{23}+X^{22}+X^{16}+X^{12}+X^{11}+X^{10}+X^8+X^7+X^5+X^4+X^2+X+1)$$

32.2.2 Calculation Time

- When processing 32-bit data, the calculation time is four AHB clock cycles
- When processing 16-bit data, the calculation time is two AHB clock cycles
- When processing 8-bit data, the calculation time is one AHB clock cycle

32.2.3 Functional Characteristics

- Handle 8-bit, 16-bit and 32-bit data
- It can use fully programmable polynomial of which the bits are programmable (7 bits, 8 bits, 16 bits, or 32 bits)
- Programmable CRC initial value
- Independent 32-bit input/output register
- It can be used as a general-purpose 8-bit register for temporary storage
- Reversible option of I/O data
- The data width can be dynamically adjusted to reduce the number of times of calculating and writing
- The high and low levels of input data can be reversed in order to adapt to different data storage methods (byte, half word or word, little-endian and big-endian system)
- Word or byte calculation can be performed, depending on the different data formats written
- Have input buffer to reduce wait cycles and avoid bus blocking

CRC unit contains a 32-bit read/write register `CRC_DATA`, used to write new data and give CRC computing results. Every time a new data is written, the result will be a combination of the last calculation result and the new calculation result. (Execute operation for the whole word). For `CRC_DATA`, word or right aligned half word or right aligned byte can be accessed, while other registers can only access 32 bits.

Programmable polynomial

Only after the application program is reset or after `CRC_DATA` is read, can the size of the polynomial be selected or changed by setting the `POLSEL` bit in `CRC_CTRL` register, which means that in CRC computing, the value or size of the polynomial cannot be changed.

32.3 Register Address Mapping

Table 111 CRC Register Address Mapping

Register name	Description	Offset address
CRC_DATA	Data register	0x00
CRC_INDATA	Independent data register	0x04
CRC_CTRL	Control register	0x08
CRC_INITVAL	CRC initial value register	0x10
CRC_POL	CRC polynomial register	0x14

32.4 Register Functional Description

32.4.1 Data register (CRC_DATA)

Offset address: 0x00

Reset value: 0xFFFF FFFF

Field	Name	R/W	Description
31:0	DATA	R/W	32bit Data As the input register: Store the new data of CRC calculator when writing. As the output register: Return the results of CRC computing when reading.

32.4.2 Independent data register (CRC_INDATA)

Offset address: 0x04

Reset value: 0x0000 0000

Field	Name	R/W	Description
7:0	INDATA	R/W	Independent 8bit Data Can be used for temporary storage of 1-byte data. CRC reset generated by RST bit of the register CRC_CTRL has no effect on this register.
31:8			Reserved.

Note: This register does not take part in calculation and can store any data.

32.4.3 Control register (CRC_CTRL)

Offset address: 0x08

Reset value: 0x0000 0000

Field	Name	R/W	Description
0	RST	R/S	Reset CRC Calculation Unit Set the data register to 0xFFFF FFFF. It can only set this bit, which shall be automatically cleared by hardware.
2:1			Reserved
4:3	POLSEL	R/W	Programmable Polynomial Size Select 00: 32 bits 01: 16 bits

Field	Name	R/W	Description
			10: 8 bits 11: 7 bits
6:5	REVI	R/W	Input Data Reverse Reverse the input data in different units. 00: Not reversed 01: In byte 10: In half-word 11: In word
7	REVO	R/W	Output Data Reverse 0: Not reversed 1: Reversed
31:8	Reserved		

32.4.4 CRC initial value register (CRC_INITVAL)

Offset address: 0x10

Reset value: 0xFFFF FFFF

Field	Name	R/W	Description
31:0	VALUE	R/W	Initial CRC Value The CRC initial value is programmable, and this bit is used to set the CRC initial value.

32.4.5 CRC polynomial register (CRC_POL)

Offset address: 0x14

Reset value: 0x04C1 1DB7

Field	Name	R/W	Description
31:0	PPOL	R/W	Programmable Polynomial Programmable polynomial coefficients can be written. If the coefficient is less than 32 bits, the correct value must be programmed with the least significant bit.

33 Chip Electronic Signature

33.1 Introduction

The chip electronic signature includes flash capacity information of main memory and 96-bit unique chip ID, which have been written into the system memory area of the chip before leaving the factory, and are read-only and can not be modified by users.

33.2 Functional Description

Main use of 96-bit chip ID:

- Used as serial number
- As the password, when writing the flash memory, the code and password can be combined by algorithm to improve the security of the code in Flash
- Used for startup configuration
- The reference number provided by the identity is unique to any MCU series. Users cannot change the unique ID under no circumstances. According to different usage, users can choose to read the identity in byte, half word, or full word.

33.3 Register Functional Description

33.3.1 96-bit Unique Chip ID

Base address: 0x1FFF F7AC

Offset address: 0x00

Field	Name	R/W	Description
31:0	U_ID[31:0]	R	Unique identity flag 31:0 bit

Offset address: 0x04

Read-only, the value has been prepared before leaving the factory

Field	Name	R/W	Description
31:0	U_ID[63:32]	R	Unique identity flag 63:32 bits

Offset address: 0x08

Read-only, the value has been prepared before leaving the factory

Field	Name	R/W	Description
31:0	U_ID[95:64]	R	Unique identity flag 95:64 bits

33.3.2 Flash Memory Capacity Register

Base address: 0x1FFF F7CC

Offset address: 0x00

Field	Name	R/W	Description
15:0	F_SIZE	R	Flash memory capacity Indicate the capacity of main memory area of the product (in KB). For example: 0x0080=128 KB

34 Version History

Table 112 Document Version History

Date	Version	Change History
August, 2025	1.0	New

Statement

This document is formulated and published by Geehy Semiconductor Co., Ltd. (hereinafter referred to as “Geehy”). The contents in this document are protected by laws and regulations of trademark, copyright and software copyright. Geehy reserves the right to make corrections and modifications to this document at any time. Read this document carefully before using Geehy products. Once you use the Geehy product, it means that you (hereinafter referred to as the “users”) have known and accepted all the contents of this document. Users shall use the Geehy product in accordance with relevant laws and regulations and the requirements of this document.

1. Ownership

This document can only be used in connection with the corresponding chip products or software products provided by Geehy. Without the prior permission of Geehy, no unit or individual may copy, transcribe, modify, edit or disseminate all or part of the contents of this document for any reason or in any form.

The “极海” or “Geehy” words or graphics with “®” or “™” in this document are trademarks of Geehy. Other product or service names displayed on Geehy products are the property of their respective owners.

2. No Intellectual Property License

Geehy owns all rights, ownership and intellectual property rights involved in this document.

Geehy shall not be deemed to grant the license or right of any intellectual property to users explicitly or implicitly due to the sale or distribution of Geehy products or this document.

If any third party’s products, services or intellectual property are involved in this document, it shall not be deemed that Geehy authorizes users to use the aforesaid third party’s products, services or intellectual property. Any information regarding the application of the product, Geehy hereby disclaims any and all warranties and liabilities of any kind, including without limitation warranties of

non-infringement of intellectual property rights of any third party, unless otherwise agreed in sales order or sales contract.

3. Version Update

Users can obtain the latest document of the corresponding models when ordering Geehy products.

If the contents in this document are inconsistent with Geehy products, the agreement in the sales order or the sales contract shall prevail.

4. Information Reliability

The relevant data in this document are obtained from batch test by Geehy Laboratory or cooperative third-party testing organization. However, clerical errors in correction or errors caused by differences in testing environment may occur inevitably. Therefore, users should understand that Geehy does not bear any responsibility for such errors that may occur in this document. The relevant data in this document are only used to guide users as performance parameter reference and do not constitute Geehy's guarantee for any product performance.

Users shall select appropriate Geehy products according to their own needs, and effectively verify and test the applicability of Geehy products to confirm that Geehy products meet their own needs, corresponding standards, safety or other reliability requirements. If losses are caused to users due to user's failure to fully verify and test Geehy products, Geehy will not bear any responsibility.

5. Legality

USERS SHALL ABIDE BY ALL APPLICABLE LOCAL LAWS AND REGULATIONS WHEN USING THIS DOCUMENT AND THE MATCHING GEEHY PRODUCTS. USERS SHALL UNDERSTAND THAT THE PRODUCTS MAY BE RESTRICTED BY THE EXPORT, RE-EXPORT OR OTHER LAWS OF THE COUNTRIES OF THE PRODUCTS SUPPLIERS, GEEHY, GEEHY DISTRIBUTORS AND USERS. USERS (ON BEHALF OR ITSELF, SUBSIDIARIES AND AFFILIATED ENTERPRISES) SHALL AGREE AND PROMISE TO ABIDE BY ALL APPLICABLE LAWS AND REGULATIONS ON THE EXPORT AND RE-EXPORT OF GEEHY PRODUCTS AND/OR TECHNOLOGIES AND DIRECT PRODUCTS.

6. Disclaimer of Warranty

THIS DOCUMENT IS PROVIDED BY GEEHY "AS IS" AND THERE IS NO WARRANTY OF ANY KIND, EITHER EXPRESSED OR IMPLIED, INCLUDING, BUT NOT LIMITED TO, THE WARRANTIES OF MERCHANTABILITY AND FITNESS FOR A PARTICULAR PURPOSE, TO THE EXTENT PERMITTED BY APPLICABLE LAW.

GEEHY'S PRODUCTS ARE NOT DESIGNED, AUTHORIZED, OR WARRANTED FOR USE AS CRITICAL COMPONENTS IN MILITARY, LIFE-SUPPORT, POLLUTION CONTROL, OR HAZARDOUS SUBSTANCES MANAGEMENT SYSTEMS, NOR WHERE FAILURE COULD RESULT IN INJURY, DEATH, PROPERTY OR ENVIRONMENTAL DAMAGE.

IF THE PRODUCT IS NOT LABELED AS "AUTOMOTIVE GRADE," IT SHOULD NOT BE CONSIDERED SUITABLE FOR AUTOMOTIVE APPLICATIONS. GEEHY ASSUMES NO LIABILITY FOR THE USE BEYOND ITS SPECIFICATIONS OR GUIDELINES.

THE USER SHOULD ENSURE THAT THE APPLICATION OF THE PRODUCTS COMPLIES WITH ALL RELEVANT STANDARDS, INCLUDING BUT NOT LIMITED TO SAFETY, INFORMATION SECURITY, AND ENVIRONMENTAL REQUIREMENTS. THE USER ASSUMES FULL RESPONSIBILITY FOR THE SELECTION AND USE OF GEEHY PRODUCTS. GEEHY WILL BEAR NO RESPONSIBILITY FOR ANY DISPUTES ARISING FROM THE SUBSEQUENT DESIGN OR USE BY USERS.

7. Limitation of Liability

IN NO EVENT, UNLESS REQUIRED BY APPLICABLE LAW OR AGREED TO IN WRITING WILL GEEHY OR ANY OTHER PARTY WHO PROVIDES THE DOCUMENT AND PRODUCTS "AS IS", BE LIABLE FOR DAMAGES, INCLUDING ANY GENERAL, SPECIAL, DIRECT, INCIDENTAL OR CONSEQUENTIAL DAMAGES ARISING OUT OF THE USE OR INABILITY TO USE THE DOCUMENT AND PRODUCTS (INCLUDING BUT NOT LIMITED TO LOSSES OF DATA OR DATA BEING RENDERED INACCURATE OR LOSSES SUSTAINED BY USERS OR THIRD PARTIES). THIS COVERS POTENTIAL DAMAGES TO PERSONAL SAFETY, PROPERTY, OR THE ENVIRONMENT,

FOR WHICH GEEHY WILL NOT BE RESPONSIBLE.

8. Scope of Application

The information in this document replaces the information provided in all previous versions of the document.

© 2025 Geehy Semiconductor Co., Ltd. - All Rights Reserved